

MAHA BODHI SCHOOL  
2021 PRACTICE PAPER  
SCIENCE  
PRIMARY FOUR

Name : \_\_\_\_\_ (        )      Date : \_\_\_\_\_

Class : Primary 4 \_\_\_\_\_

Duration : 50 min

Marks: / 30

Parent's signature : \_\_\_\_\_

**Section A : [8 x 2 marks = 16 marks]**

For each question from 1 to 8, four options are given. One of them is the correct answer. Make your choice (1, 2, 3 or 4). Write your answer in the bracket.

1. Which one of the following is the best conductor of heat?

- (1) glass rod
- (2) metal rod
- (3) plastic rod
- (4) wooden rod

(        )

2. Ray placed a metal spoon in a beaker of hot water.

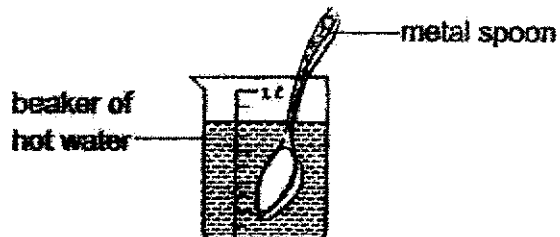

The spoon became hotter after a while.

Which one of the following explains this?

- (1) The spoon lost heat to the hot water.
- (2) The beaker lost heat to the hot water.
- (3) The hot water gained heat from the spoon.
- (4) The spoon gained heat from the hot water.

Marks : (        )  
/ 4

3. Which of the following is a source of light?

(1)



book

(2)



candle flame

(3)



moon

(4)

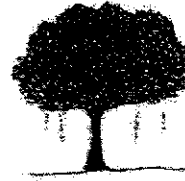

tree

( )

4. Matter is anything that has mass and occupies space. Which of the following is NOT matter?

(1) air

(2) water

(3) eraser

(4) shadow

( )

Marks :

5. The diagrams below show beakers with different amounts of water and temperature.

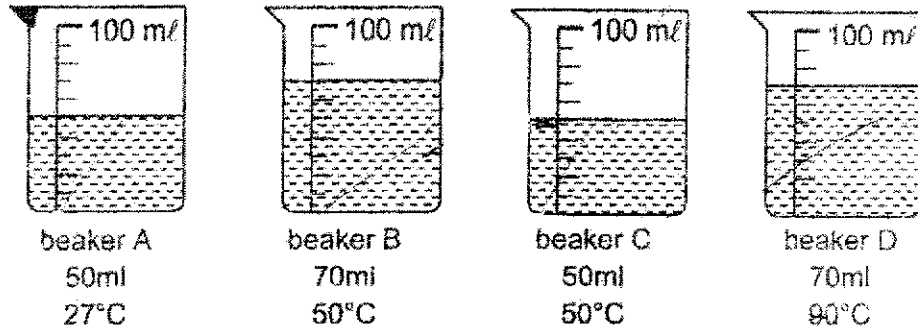

Based on the diagrams, rank the beakers based on the amount of heat the water inside them has in an increasing order.

	Least amount of heat $\longrightarrow$ Most amount of heat			
(1)	A	C	B	D
(2)	A	B	C	D
(3)	B	D	A	C
(4)	D	B	C	A

( )

6. John placed two ice cubes of the same mass and size on two similar plates. One of the plates is made of metal and the other, plastic.

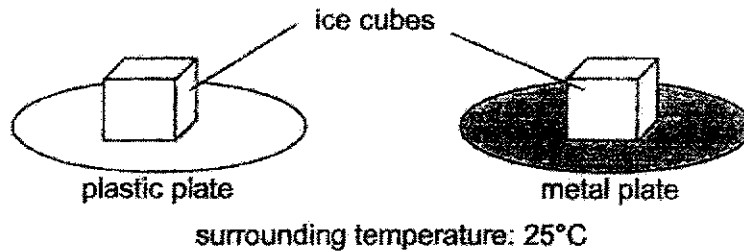

Which of the following choices below correctly states what he will observe as time passes?

- (1) Both ice cubes will not melt.
- (2) Both ice cubes will melt equally fast.
- (3) The ice cube on the metal plate will melt faster.
- (4) The ice cube on the plastic plate will melt faster.

( )

Marks :  / 4

7. Study the diagram below.

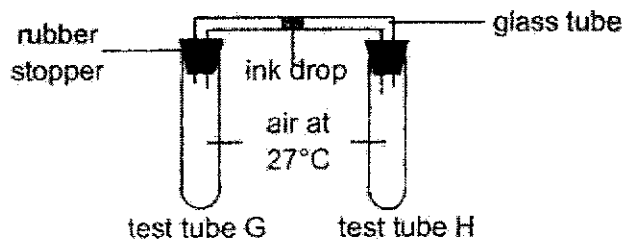

The ink drop in a glass tube was in between two test tubes, G and H.

When the test tube G was placed in a container of ice water as shown below, the ink drop moved.

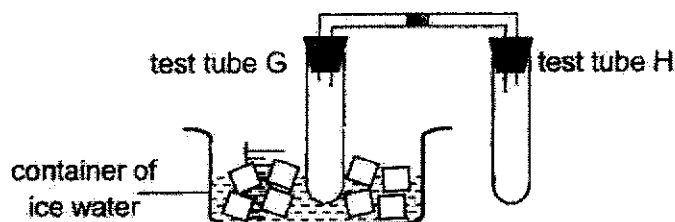

Which one of the following states the correct direction of movement of the ink drop in the glass tube and explains what happened correctly?

	Direction of movement	Explanation
(1)	←	Air inside test tube G lost heat and contracted.
(2)	←	Air inside test tube H gained heat and expanded.
(3)	→	Air inside test tube G gained heat and expanded.
(4)	→	Air inside test tube H lost heat and contracted.

( )

Marks :

12

8. Nelly prepared a set-up as shown below.

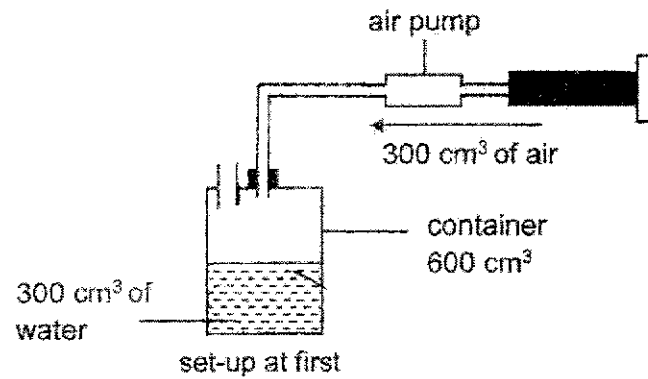

Then, she poured another  $10 \text{ cm}^3$  of water into the container before fitting an air pump to the container and pumping in  $300 \text{ cm}^3$  of air.

What is the final volume of the water and air in the container?

	Volume of water ( $\text{cm}^3$ )	Volume of air ( $\text{cm}^3$ )
(1)	300	300
(2)	300	600
(3)	310	290
(4)	310	600

( )

Marks :  / 2

**SECTION B : [14 marks]**

For questions 9 to 13, write your answers in this booklet.

The number of marks available is shown in the brackets [ ] at the end of each question or part-question.

---

9. William used an instrument to measure the temperature of water in a glass.

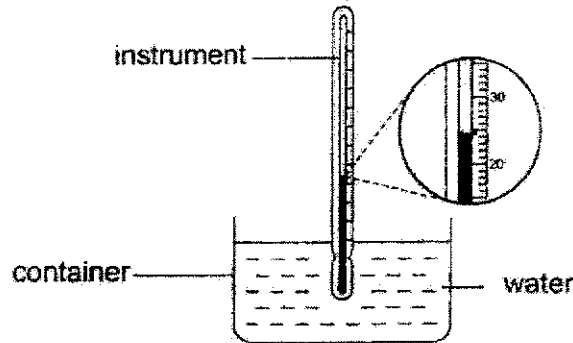

(a) What is the instrument called? [1]

---

(b) What is the temperature of water in the glass? [1]

\_\_\_\_\_ °C

10. Lewis is able to read his book in a dark room with the help of a table lamp.

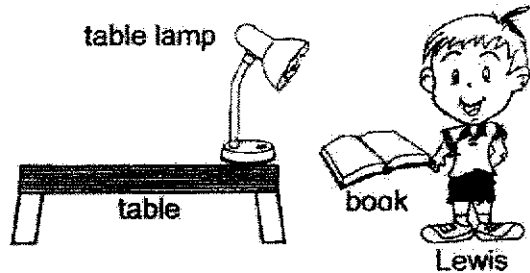

Describe how Lewis is able to read his book in the dark room. [2]

---

---

Marks: 

/ 4
-----

11. Penny conducted an experiment using the set-up shown below.

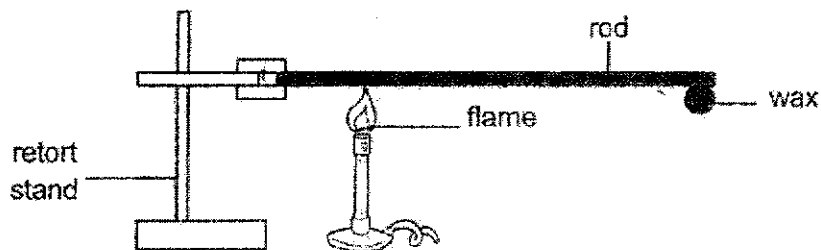

She observed that after some time, the wax melted.

- (a) State whether the wax gained heat or lost heat as it melted. [1]

---

- (b) Describe the change in state of the wax. [1]

---



---

- (c) Penny recorded the amount of time taken for the wax to drop off the rod. She then repeated the experiment using rods of different materials. The time taken for the wax to drop off the different rods are as shown.

Material	Time taken for wax to drop off (min)
E	6.0
F	3.0
G	15.0

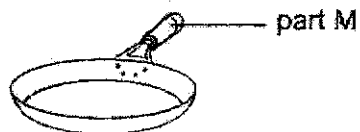

Based on the results, which material is most suitable to be used to make the part M of a frying pan so that the cook will not burn his/her hands easily? Explain your answer. [2]

---



---

Marks:  / 4

12. Gina used a torchlight to shine light at an object. She noticed that a shadow of the object was formed on the screen.

(a) State how a shadow is formed. [1]

---

---

(b) In another test, Gina wanted to find out how different materials affect the amount of light captured by the light sensor. She used the set-up shown below.

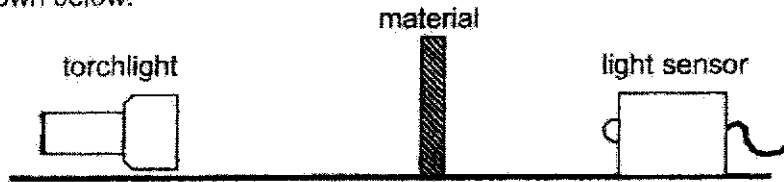

The amount of light captured by the light sensor is as shown.

Material	Amount of light captured (units)
X	760
Y	50
Z	290

Gina would like to use one of the materials to create part G of her photo frame as shown below. The part should allow her to see the photo behind it most clearly.

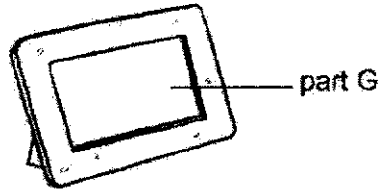

Which material, X, Y or Z, should Gina use to create part G? Explain your choice. [2]

---

---

---

Marks: 

/ 3
-----



13. Cup M was completely filled with marbles as shown below.

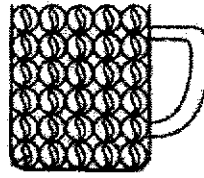

Cup M

- (a) When a marble was removed from Cup M, the shape of the marble did not change. What state of matter is the marble in? [1]

---

- (b) The marble was then placed back, and water was poured into cup M. Although the cup was filled with marbles, the water did not overflow. Explain why. [2]

---

---

Marks: 

/ 3
-----

~ END OF PAPER ~

This is the property of Maha Bodhi School.

No part of this should be duplicated without the permission of the school.



**SCHOOL : MAHA BODHI SCHOOL**  
**LEVEL : PRIMARY 4**  
**SUBJECT : SCIENCE**  
**TERM : PRACTISE PAPER**

**SECTION A**

Q1	Q2	Q3	Q4	Q5	Q6	Q7	Q8
2	4	2	4	1	3	1	3

**SECTION B**

Q9	a) Thermometer b) 24°C
Q10	The light table lamp shone light onto the book which reflected light into Lewis' eyes
Q11	a) The wax gained heat. b) The wax changed from solid to liquid c) Material G. The wax on material G took the longest amount of time to drop off. So material G is the poorest conductor of heat.
Q12	a) A shadow is formed when light is completely or partially blocked by an object. b) Materials X. The light sensor captured the most amount of light for materials X. Therefore, material X allows the most amount of light to pass through.
Q13	a) Solid b) There are air gaps in between the marble as water has no definite shape, it can flow into these gaps. Therefore, water took up the spaces previously occupied by air.

