

METHODIST GIRLS' SCHOOL
Founded in 1887



END-OF-YEAR EXAMINATION 2024
PRIMARY 5
SCIENCE

BOOKLET A

Total Time for Booklets A and B: 1 hour 45 minutes

INSTRUCTIONS TO CANDIDATES

Do not turn over this page until you are told to do so.

Follow all instructions carefully.

Answer all questions.

Shade your answers in the Optical Answer Sheet (OAS) provided.

Name: _____ ()

Class: Primary 5. _____

Date: 22 October 2024

This booklet consists of 20 printed pages including this page.

For each question from 1 to 28, four options are given. One of them is the correct answer. Make your choice (1, 2, 3 or 4). Shade the correct oval on the Optical Answer Sheet (OAS).

[56 marks]

- 1 The table below shows characteristics of three living things, X, Y and Z.

Living thing	Makes its own food	Reproduces by laying eggs	Moves freely from place to place
X	✓		
Y		✓	✓
Z			✓

Based on the table above, which of the following statements is/are correct?

- A Y can be a bird or reptile.
 B Z could be a mammal or fungi.
 C X has cells containing chloroplasts.

- (1) A and B only
 (2) A and C only
 (3) B and C only
 (4) A, B and C

(Go on to the next page)

2 Study the flowchart below.

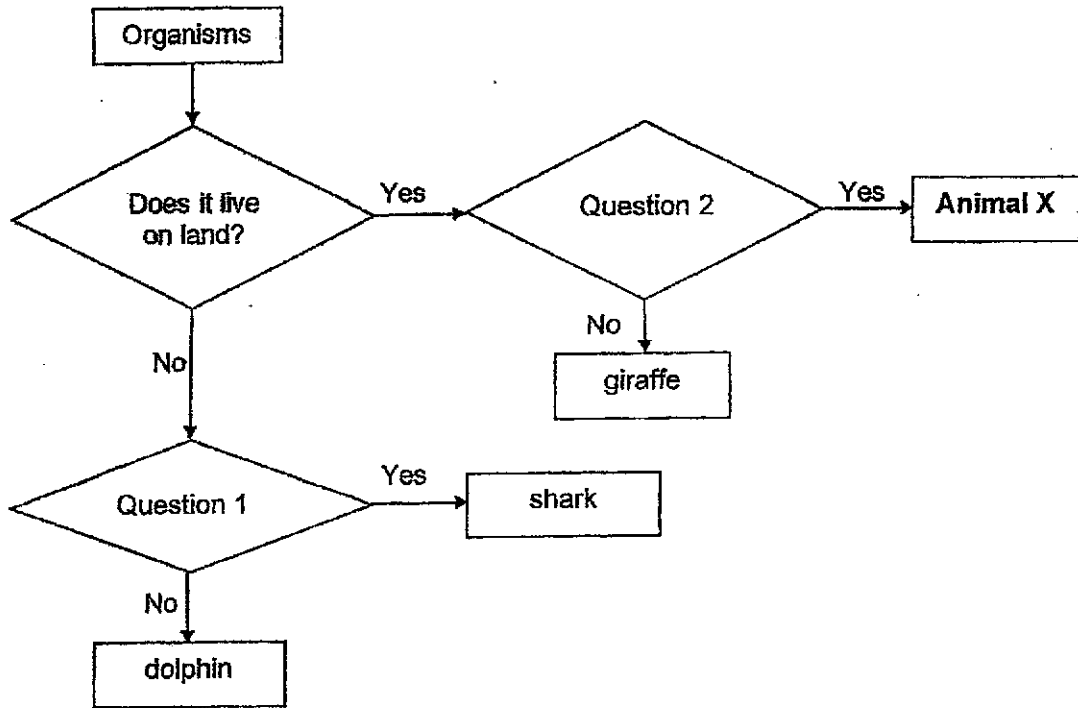

Which of the following is correct?

	Question 1	Question 2	Animal X
(1)	Does it have lungs?	Does it lay eggs?	frog
(2)	Does it give birth to live young?	Does it have moist skin?	frog
(3)	Does it lay eggs?	Does it have hair?	snake
(4)	Does it have gills?	Does it have dry skin covered with scales?	snake

- 3 Jane placed four identical pieces of bread into four sealed containers as shown below.

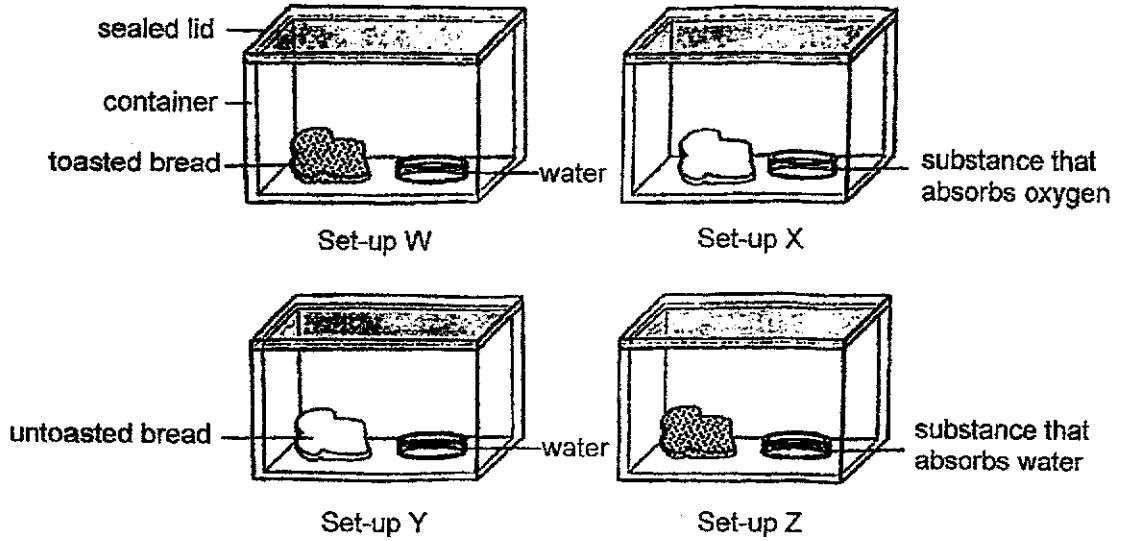

She left all four set-ups on a table in the Science room for two weeks. She recorded her observations of mould growth in the table below.

	Day 4	Day 9	Day 14
Set-up W	no mould	no mould	some mould
Set-up X	no mould	no mould	no mould
Set-up Y	some mould	many patches of mould	many patches of mould
Set-up Z	no mould	no mould	no mould

Based on the above results, what could Jane conclude?

- A Light is not needed for mould to grow.
- B Oxygen and water are needed for mould to grow.
- C When there is more water, more mould will grow.

- (1) A and B only
- (2) A and C only
- (3) B and C only
- (4) A, B and C

(Go on to the next page)

- 4 The graph below shows the changes in the amount of undigested food for three different food substances, W, X and Y when they pass through parts of the human digestive system.

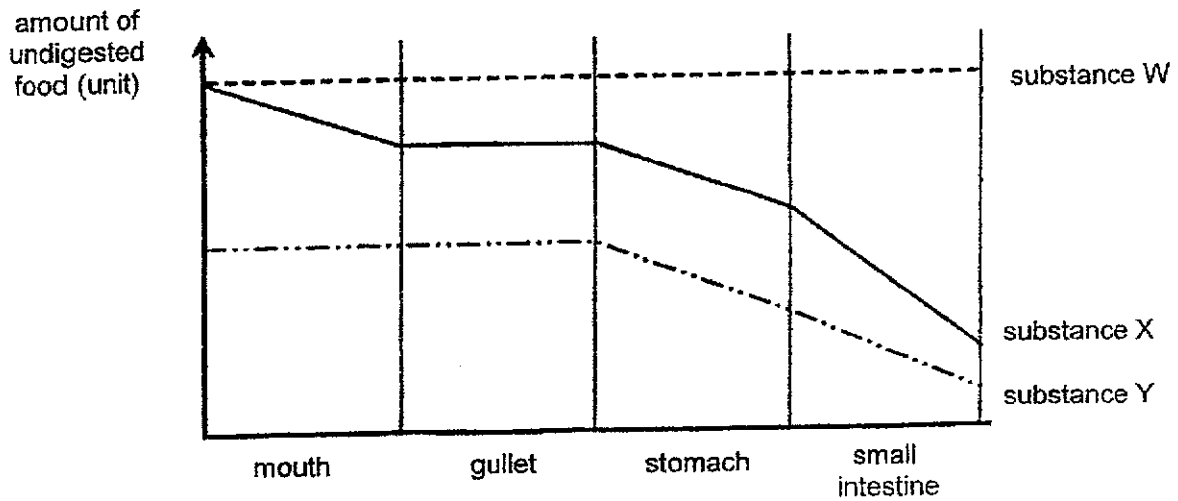

Based on the above, which of the following statements are correct?

- A Substance Y cannot be digested.
- B Substance W cannot be absorbed into the blood.
- C Substance X is digested the most in the small intestine.
- D Substances X and Y are digested at different rates in the small intestine.

- (1) A and B only
- (2) A and D only
- (3) A, B and C only
- (4) B, C and D only

(Go on to the next page)

- 5 The diagram below shows different systems, W, X and Y, in the human body working together.

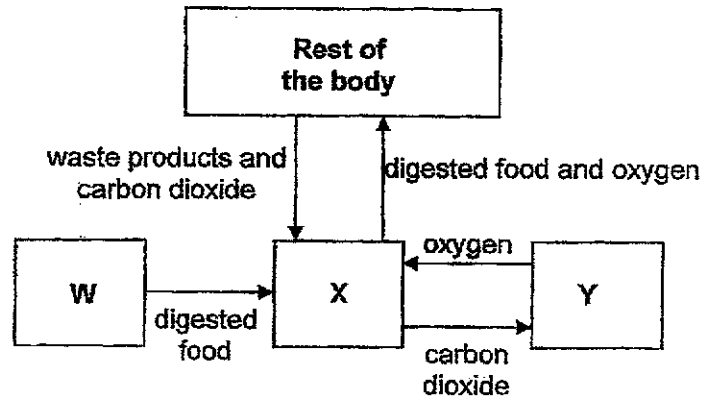

Which of the following body systems correctly represents W, X and Y?

	W	X	Y
(1)	digestive	respiratory	circulatory
(2)	circulatory	respiratory	digestive
(3)	respiratory	circulatory	digestive
(4)	digestive	circulatory	respiratory

- 6 The table below shows the cell parts found in Cells J, K, L and M.

Cell part	Cell J	Cell K	Cell L	Cell M
nucleus	✓	✓	✓	✓
cell membrane	✓	✓	✓	✓
cell wall	✓	✓		
cytoplasm	✓	✓	✓	✓
chloroplasts	✓		✓	

Based on the table, which of the following statements are definitely correct?

- A Only cells J and L can make food.
- B Both cells K and M are most likely animal cells.
- C Cell M is taken from an animal while cell J is taken from a plant.

- (1) A and B only
- (2) A and C only
- (3) B and C only
- (4) A, B and C

- 7 The diagrams below show two cells, P and Q, that belong to the same organism.

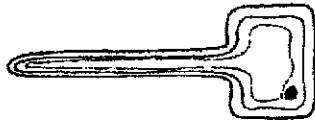

cell P

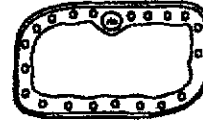

cell Q

Based on the diagrams, which part of the cell determines that both cells belong to the same organism?

- (1) nucleus
 - (2) cell wall
 - (3) cytoplasm
 - (4) cell membrane
- 8 The diagram below shows the movement of substances in a plant.

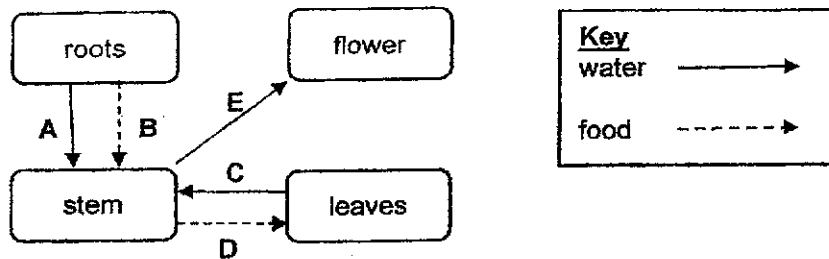

Which arrows are drawn **incorrectly**?

- (1) A and E only
- (2) B and E only
- (3) A, C and E only
- (4) B, C and D only

9 The diagram below shows the seed dispersal patterns of four different plants, J, K, L and M, in a location. The symbols representing the parent plants are shaded.

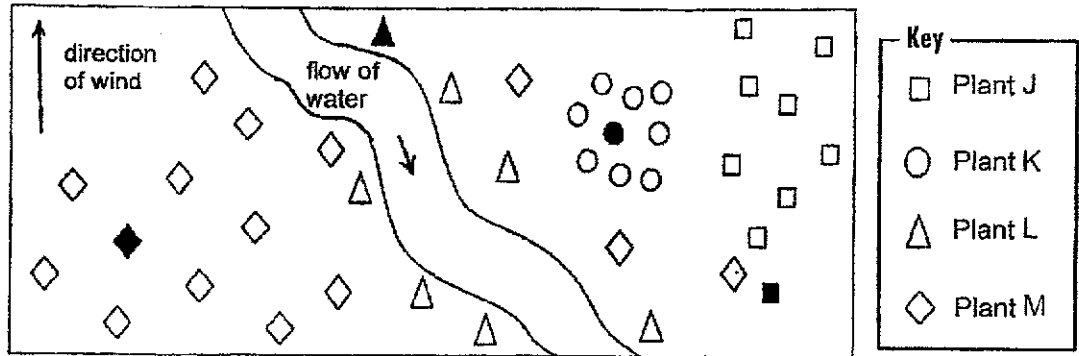

The diagrams below show the fruits/seeds of the four different plants, W, X, Y and Z.

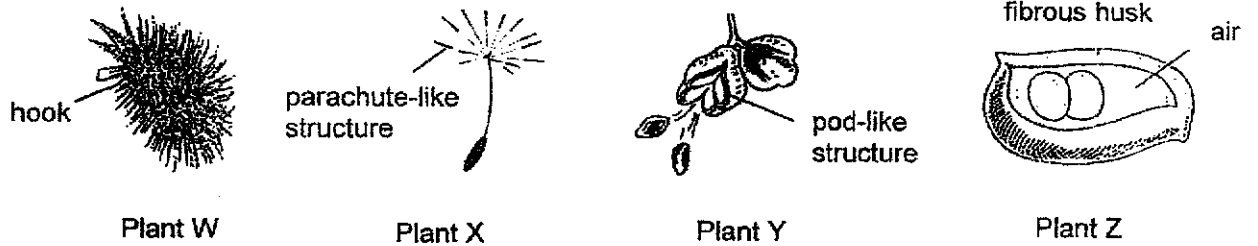

Which of the above plants can be Plant M?

- (1) Plant W only
- (2) Plant Y only
- (3) Plants W and Z only
- (4) Plants X and Z only

10 Study the flowchart below on different types of flowers.

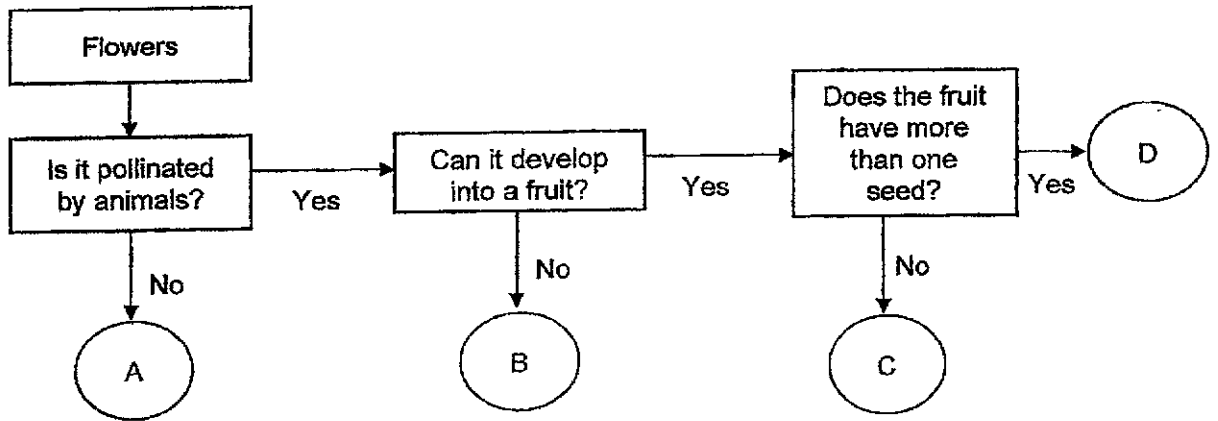

The diagrams of six flowers are shown below.

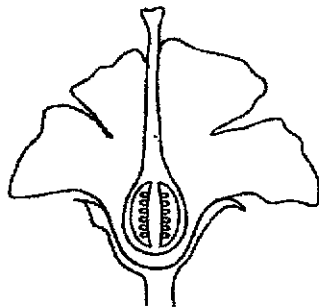

Flower P

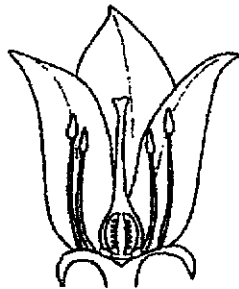

Flower Q

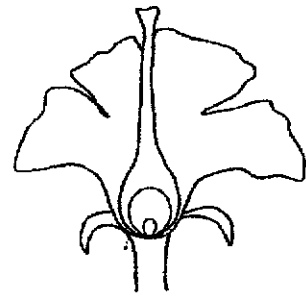

Flower R



Flower S

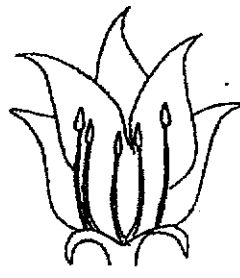

Flower T

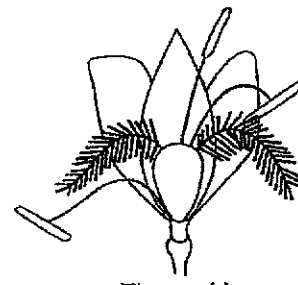

Flower U

Which of the following correctly matches the flowers to A, B, C and D?

	A	B	C	D
(1)	U	T	R	P
(2)	S	P	Q	R
(3)	R	T	U	Q
(4)	U	S	P	R

(Go on to the next page)

- 11 The diagram below shows the reproductive systems of a human male, a human female, and a flower.

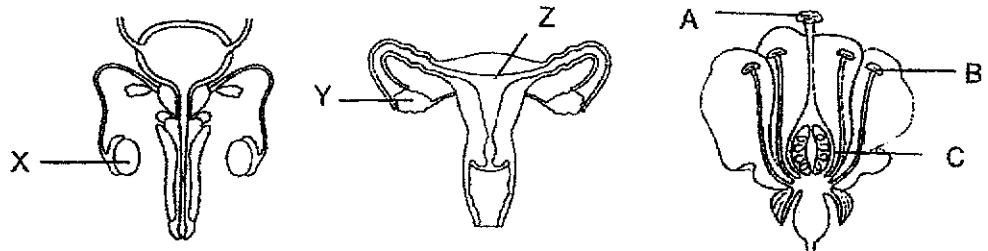

Which of the following statements are correct?

- A The fertilised cells develop in Z and C.
- B Male reproductive cells are produced in X and B.
- C Female reproductive cells are produced in C and Y.
- D Pollination and fertilisation occur in all three reproductive systems.

- (1) A and B only
- (2) C and D only
- (3) A, B and C only
- (4) All of the above

(Go on to the next page)

- 12 Before her evening run, Xuanshuang did some warm-up exercises for 5 min before resting for 5 min. She started to run up a slope for 10 min and then sat down to rest for 10 min.

Which of the following graph correctly shows her heart rate during this 30-minute period?

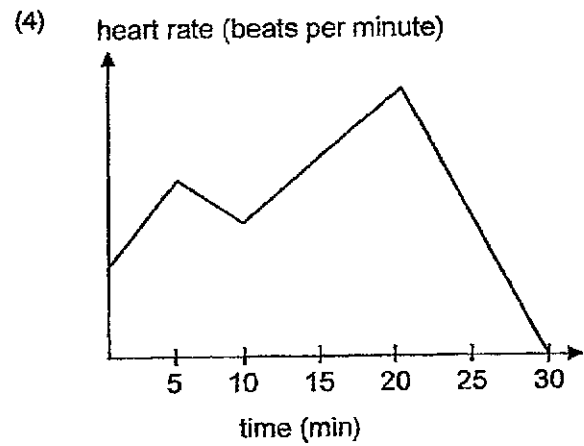
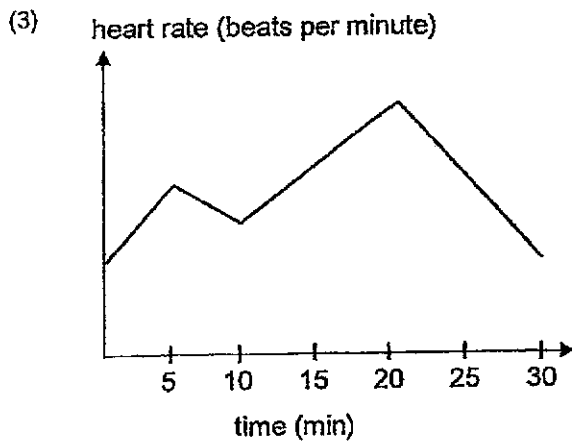
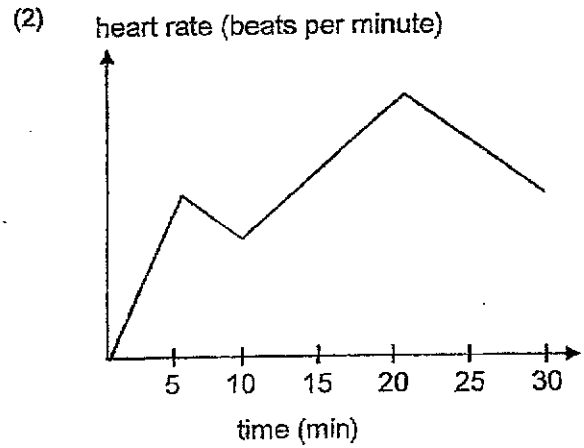
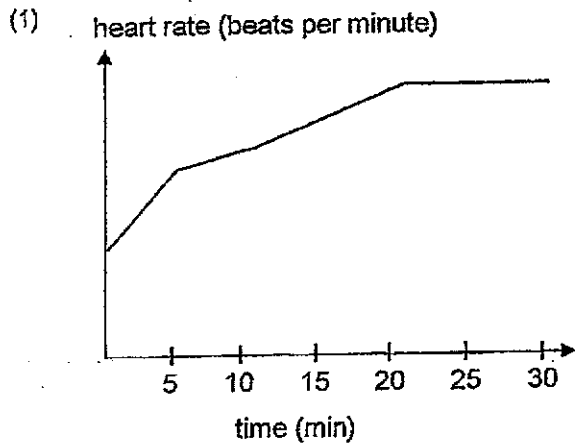

(Go on to the next page)

- 13 Some workers were trapped in the lift.

Which one of the following graphs shows the correct volume of oxygen and carbon dioxide in the lift after 1 hour?

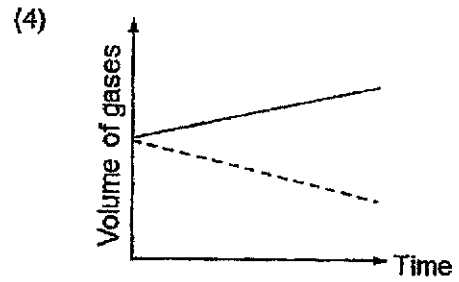
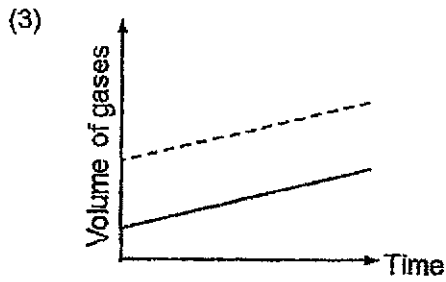
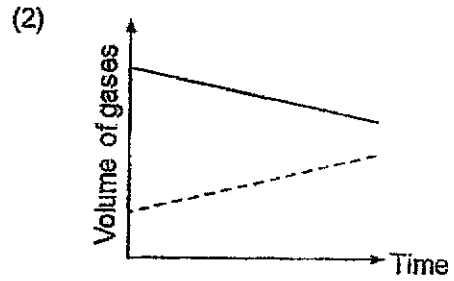
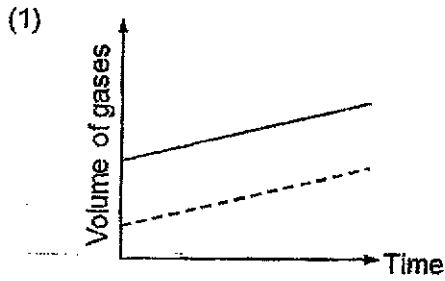
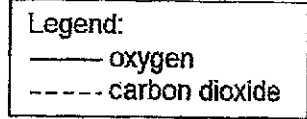

- 14 Which of the following are examples of matter?

- A mist
- B light
- C water vapour
- D carbon dioxide

- (1) A and B only
- (2) C and D only
- (3) A, B and C only
- (4) A, C and D only

- 15 Jaya wanted to study the effect of carbon dioxide given out by fish on the growth of water plants. The set-ups, A, B, C and D, were placed next to a window.

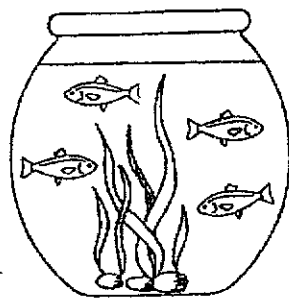

Set-up A

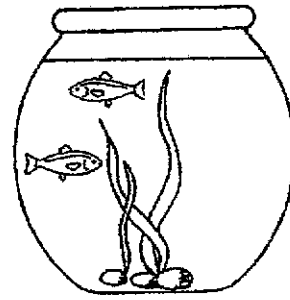

Set-up B

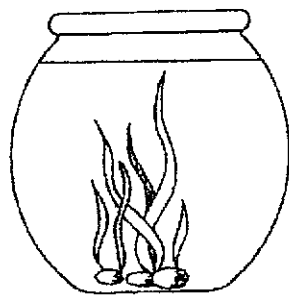

Set-up C

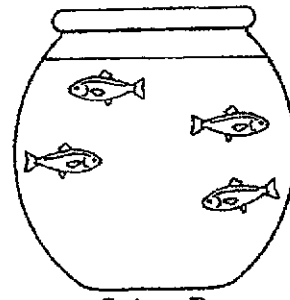

Set-up D

Which two set-ups should Jaya use for this experiment?

- (1) A and B
 - (2) A and C
 - (3) B and C
 - (4) B and D
- 16 The table below shows the properties of two objects, A and B.

Property	A	B
It is flexible.	✓	
It breaks easily.		✓
It is waterproof.	✓	✓
It does not allow light to pass through.	✓	✓

Which one of the following best represents objects A and B?

	A	B
(1)	plastic ruler	rubber glove
(2)	rubber tyre	ceramic spoon
(3)	wooden pencil	tissue paper
(4)	plastic spoon	metal ruler

(Go on to the next page)

- 17 Keith placed three solids made up of materials A, B and C of the same volume into a basin of water. The diagram below shows the result.

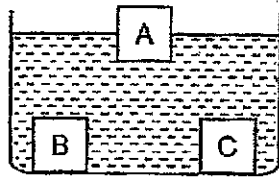

Next, he placed solids made up of the same materials but of different volumes into the basin of water. Which of the following shows the correct observation?

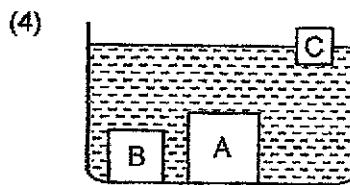
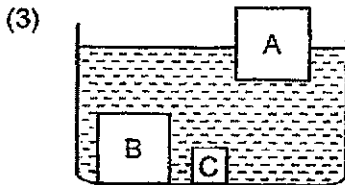
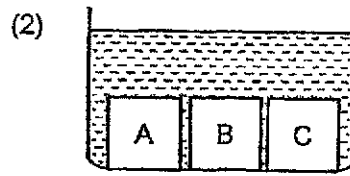
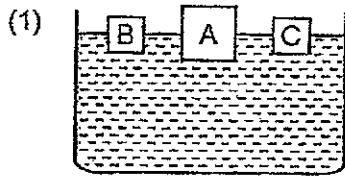

- 18 A container was filled up with 70 cm^3 of water and 30 cm^3 of air and sealed as shown below.

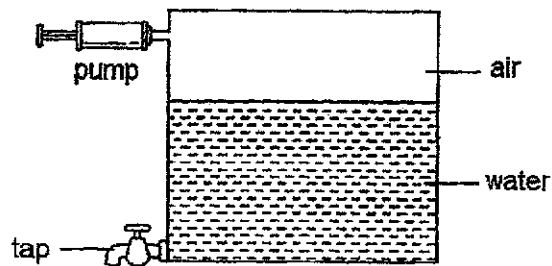

20 cm^3 of water was removed through the tap and 40 cm^3 of air of air was pumped into the container using the pump.

What would be the final volume of air in the container?

- (1) 30 cm^3
 (2) 40 cm^3
 (3) 50 cm^3
 (4) 70 cm^3

(Go on to the next page)

- 19 Refer to the diagram below. Magnets P, Q and R were placed as shown. When magnet M was placed near the end of magnet P, it moved away. A compass is placed near magnet M.

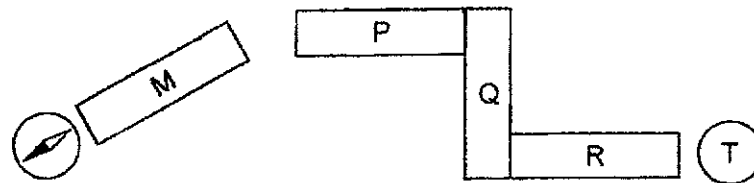

Which of the following shows the direction of the compass needle placed at T?

- (1) (2) (3) (4)

- 20 Azman moved a bar magnet W towards a paper clip slowly as shown below.

He measured and recorded d , the distance of bar magnet W from the paper clip at which the paper clip started moving towards the bar magnet.

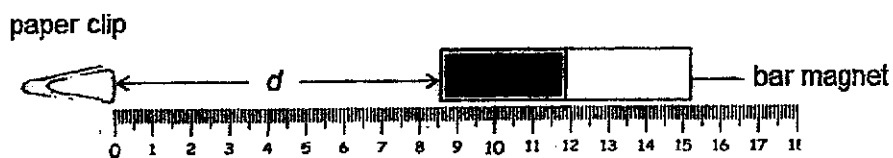

He repeated the same procedure with three other bar magnets, X, Y and Z. The results were recorded in the table below.

Magnet	Distance d (cm)
W	8.3
X	6.1
Y	9.2
Z	4.7

Which magnet has the strongest magnetic strength?

- (1) W
 (2) X
 (3) Y
 (4) Z

- 21 John was scooping ice cream with a metal scoop as shown below. After some time, he felt that the scoop was cold.

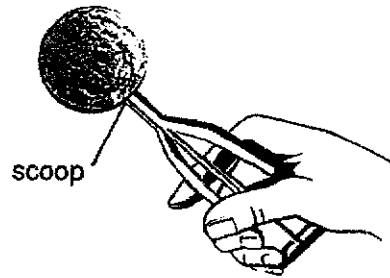

Which one of the following correctly explains why John felt that the scoop was cold?

- (1) The scoop lost heat to the ice cream and his fingers.
 - (2) The scoop gained heat from the ice cream and his fingers.
 - (3) The scoop gained heat from his fingers and lost heat to the ice cream.
 - (4) The scoop gained heat from the ice cream and lost heat to his fingers.
- 22 Two empty containers, A and B, of the same size were placed in a tank of water at 90°C as shown. The containers were made up of different materials.

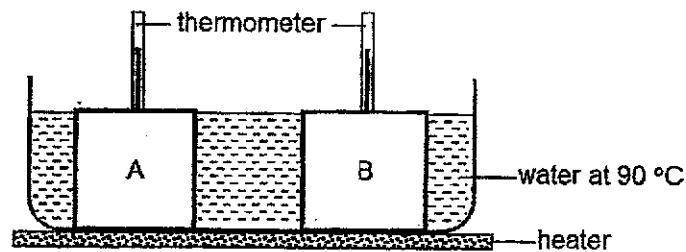

The temperature readings were taken and recorded at every 2 minutes' interval and the results are as shown in the table below.

Time (min)	0	2	4	6	8	10
Temperature of A ($^{\circ}\text{C}$)	28	30	32	34	36	38
Temperature of B ($^{\circ}\text{C}$)	28	32	36	40	44	48

Which material would be more suitable for keeping drinks cold and food hot for a long period of time?

	Material for keeping	
	cold drinks	hot food
(1)	A	A
(2)	A	B
(3)	B	A
(4)	B	B

(Go on to the next page)

- 23 Ravi placed an air-tight sealed plastic bag of ice cubes on an electronic balance which is connected to a datalogger. He left the set-up in a classroom.

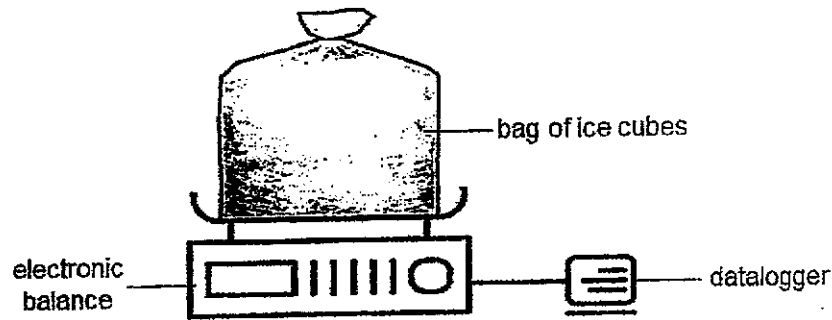

After 8 hours, he went to check on the results. Which one of the following graphs would be shown on the datalogger?

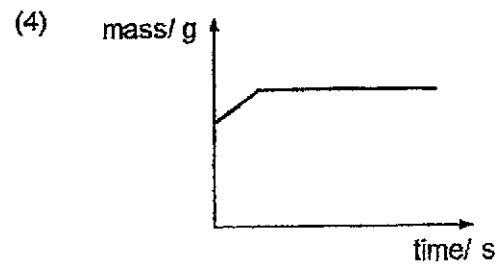
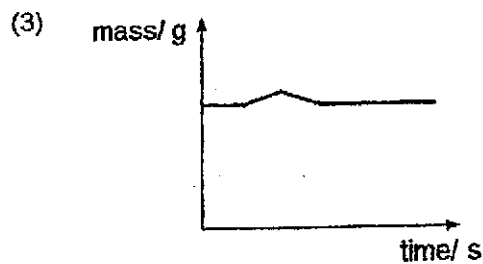
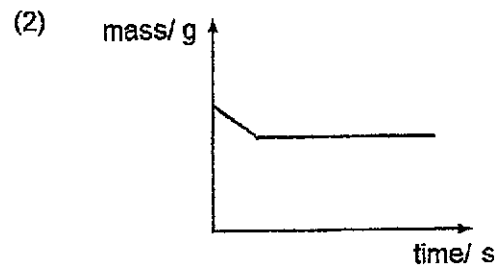
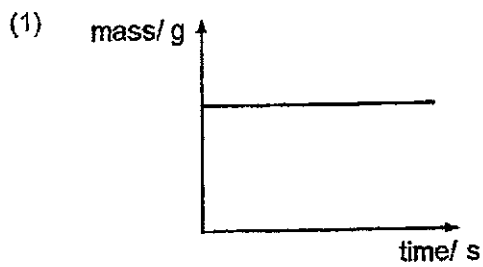

- 24 Dahlia conducted an experiment to compare the rate of evaporation of water in four identical containers, A, B, C and D, with the same amount of tap water and covered with different lids.

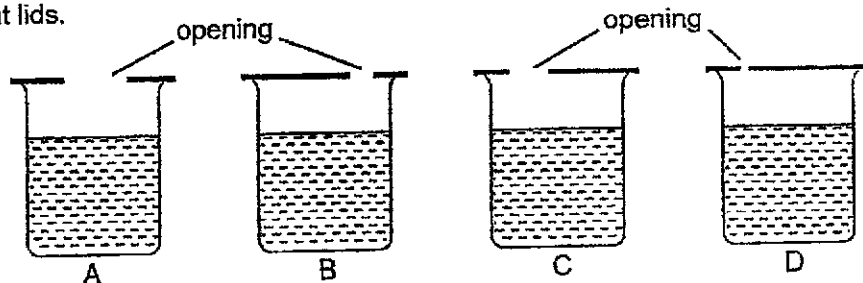

What was the changed variable in her experiment?

- (1) Material of lids
- (2) Presence of wind
- (3) Exposed surface area of water
- (4) Temperature of surrounding air

(Go on to the next page)

- 25 The diagram below shows the top view of a set-up Bernard used to investigate shadows.

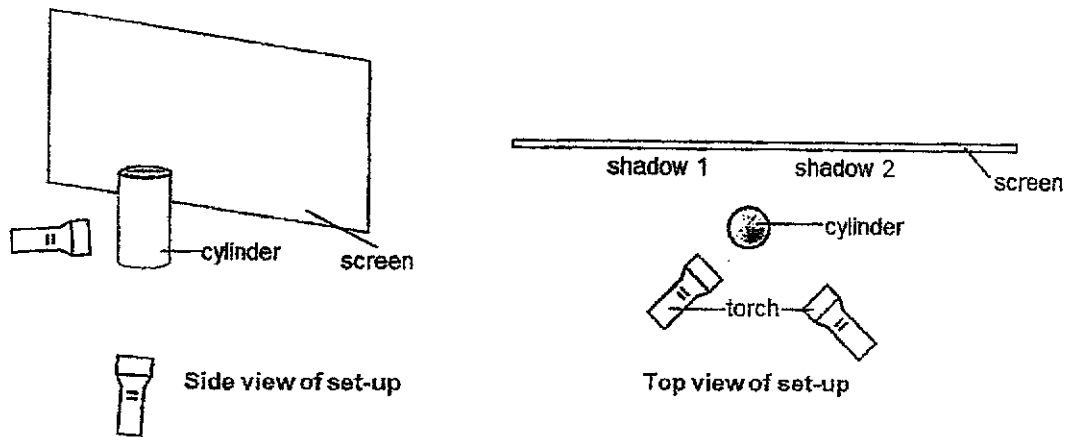

He turned on the torches and looked at the two shadows on the screen.

Which one of the following correctly shows the shadows cast on the screen?

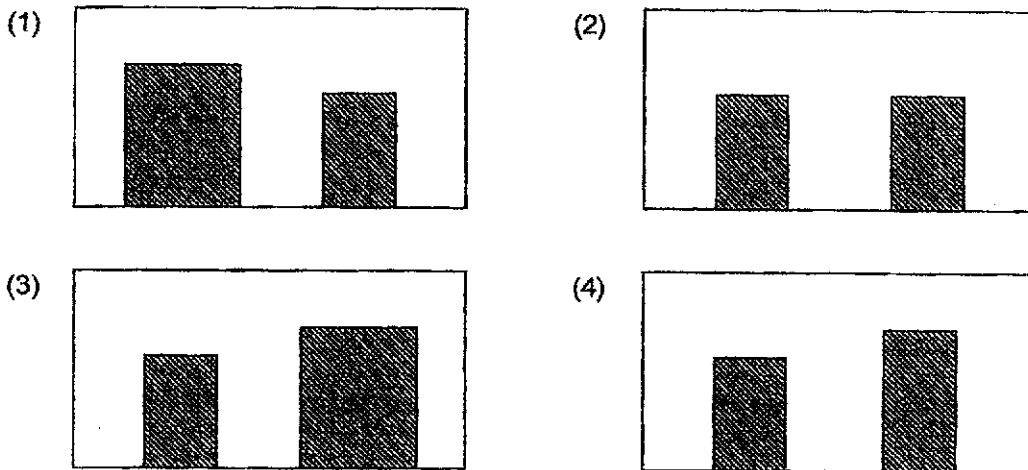

- 26 The table below shows the freezing and boiling points of three substances, A, B and C.

Substance	Freezing point ($^{\circ}\text{C}$)	Boiling point ($^{\circ}\text{C}$)
A	39	80
B	15	63
C	46	107

At which temperature will all the substances be in the liquid state?

- (1) 37°C
 (2) 60°C
 (3) 90°C
 (4) 107°C

(Go on to the next page)

- 27 Chloe set up a circuit connecting four identical bulbs, A, B, C and D.

She removed bulbs from their bulb holders one at a time and observed if the other bulbs remained lit. She recorded her results in the table below.

Bulb removed	Bulb(s) that remained lit
A	B, C and D
B	none
C	A and B
D	A and B

Based on the results above, which of the following shows the correct arrangement of her circuit?

(1)

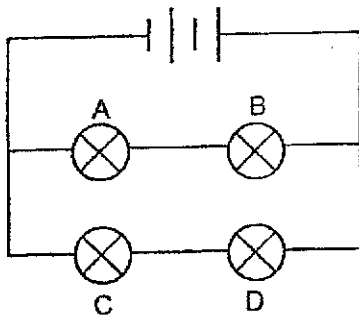

(2)

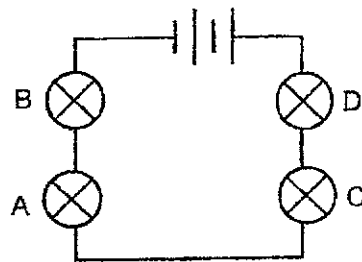

(3)

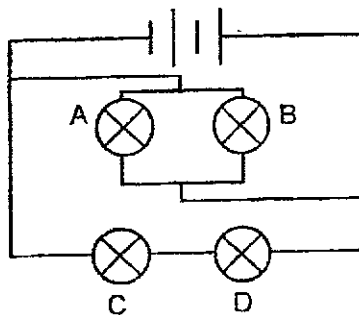

(4)

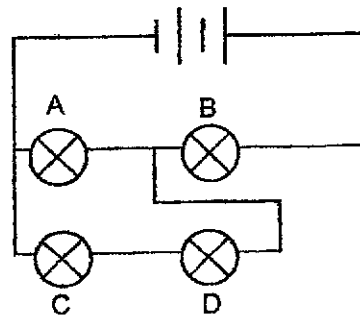

- 28 John set up four electric circuits, W, X, Y and Z, represented by the circuit diagrams below. All batteries and bulbs used are identical and in working condition.

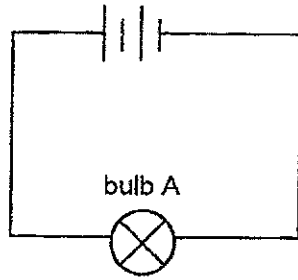

Circuit W

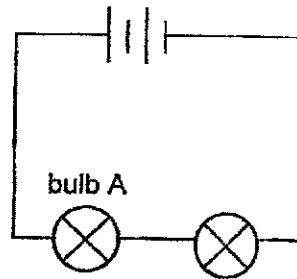

Circuit X

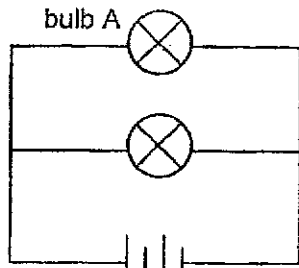

Circuit Y

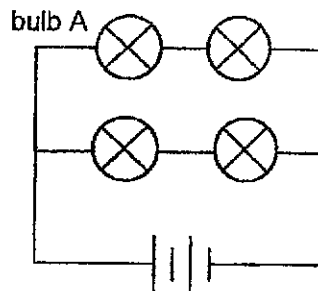

Circuit Z

Which of the following graphs correctly shows the brightness of bulb A in each circuit?

(1) brightness of bulb A (unit)

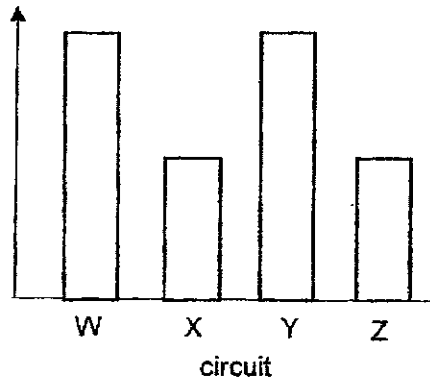

(2) brightness of bulb A (unit)

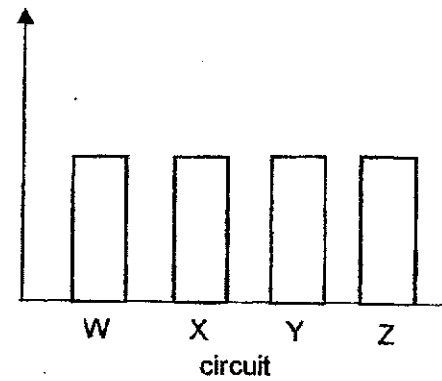

(3) brightness of bulb A (unit)

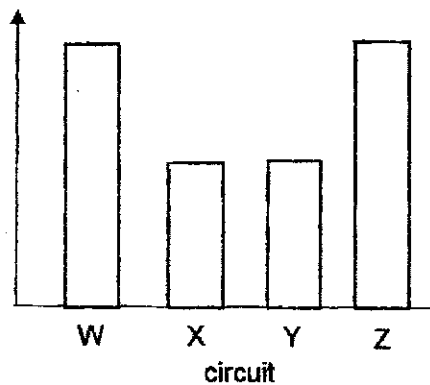

(4) brightness of bulb A (unit)

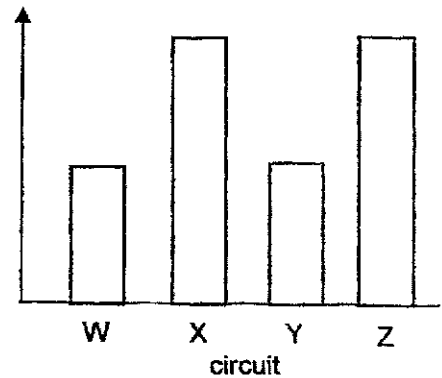

METHODIST GIRLS' SCHOOL
Founded in 1887



END-OF-YEAR EXAMINATION 2024
PRIMARY 5
SCIENCE

BOOKLET B

Total Time for Booklets A and B: 1 hour 45 minutes

INSTRUCTIONS TO CANDIDATES

Do not turn over this page until you are told to do so.

Follow all instructions carefully.

Answer all questions.

Write your answers in this booklet.

Name: _____ ()

Class: Primary 5. _____

Date : 22 October 2024

Booklet A	56
Booklet B	44
Total	100
Parent's Signature	

This booklet consists of 16 printed pages including this page.

For questions 29 to 40, write your answers in the spaces provided. The number of marks available is shown in brackets [] at the end of each question or part question.

[44 marks]

29 The diagram below shows part of the human digestive system.

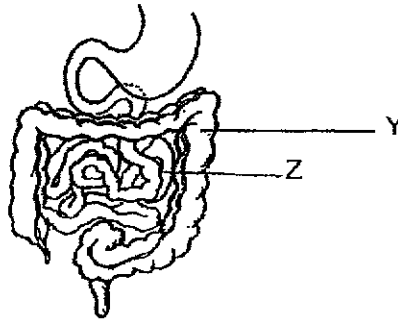

(a) State the function of Part Y.

[1]

Scientists found that Disease Q damages the walls of Part Z and stops it from functioning properly. The diagrams below show a magnified view of the inner walls of Part Z and food samples taken from Part Z of a healthy person and a person with Disease Q.

	Healthy person	Person with Disease Q
Inner walls		
Food samples	<p>Sample W</p>	<p>Sample X</p>

Key
○ Undigested food
● Digested food

(Go on to the next page)

- (b) Explain how Disease Q affects rate of absorption of digested food in a person. [2]

- (c) Describe how digested food in the blood reaches other parts of the body. [1]

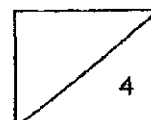

(Go on to the next page)

- 30 The diagram below shows an insect collecting nectar from a flower on a fruit tree.



- (a) Farmer Dave grew more plants with flowers which produce a pleasant scent around his fruit trees. How would this help him to harvest more fruits? [1]

The diagram below shows a fruit.

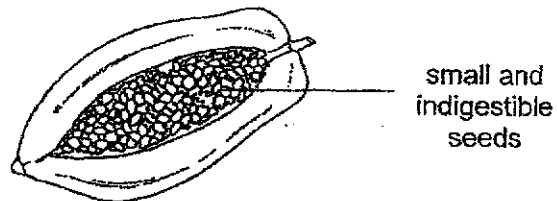

- (b) Explain how having the above characteristic helps in the dispersal of seeds. [1]

- (c) Describe the importance of seed dispersal for the fruit tree. [2]

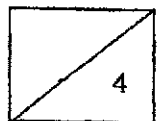

(Go on to the next page)

31 The diagram below shows a young plant.

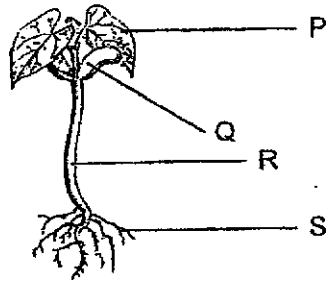

The graphs below show the changes in mass of two of the parts above as the young plant develops and grows.

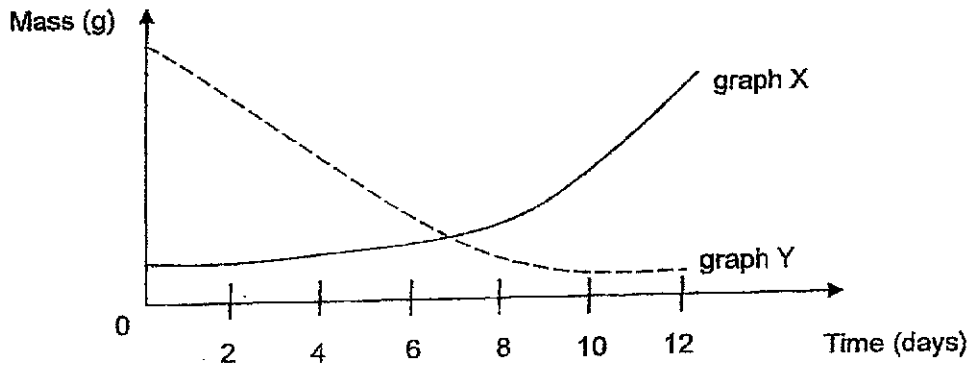

(a) Which graph, X or Y, shows the changes in mass of part Q? Explain your answer. [2]

Muthu found the following organisms, A and B, growing in a park.



Organism A

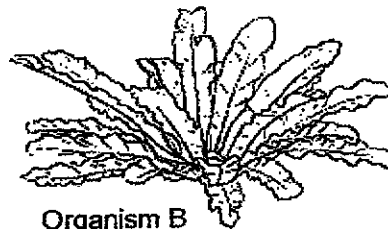

Organism B

(b) State a similarity between organisms A and B in the way they reproduce. [1]

(c) State how organisms A and B obtain food. [1]

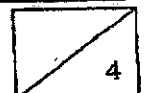

(Go on to the next page)

32(a) Study the diagram below. The arrows represent the flow of blood in blood vessels in a human body.

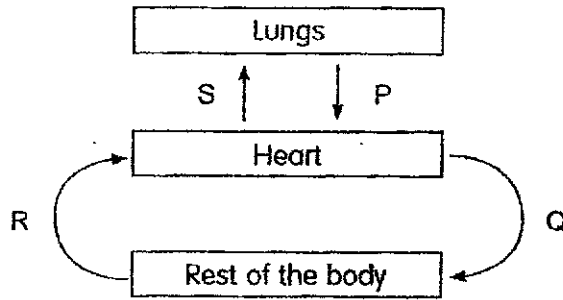

The graph below shows the amount of carbon dioxide in blood samples taken from blood vessels P, Q, R and S.

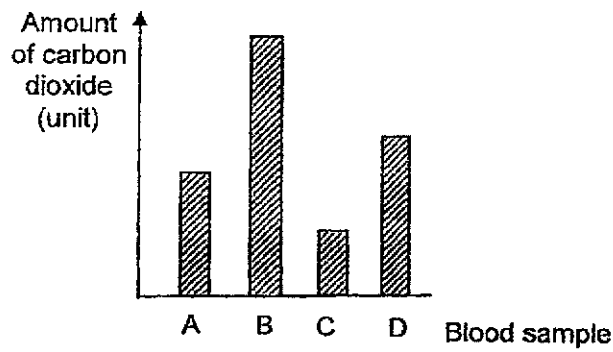

Based on the above information, which blood vessel, P, Q, R or S was blood sample B taken from? Give a reason for your answer. [1]

Cigarette smoke contains harmful chemicals that can cause severe damage to the organs. The diagrams below show the cross-section of the blood vessels in the lungs of a person who smokes and a person who does not smoke.

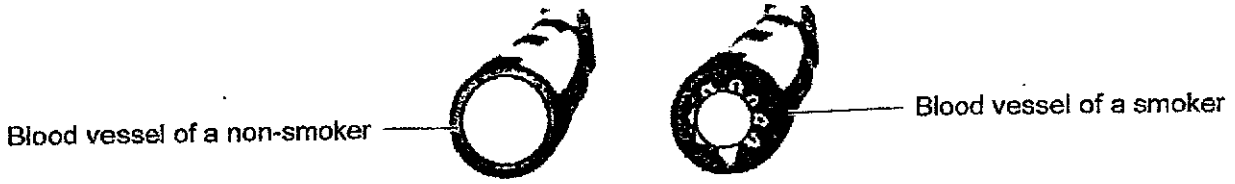

The table below shows the heart rate of two persons, Kim and Dan.

	Heart rate (beats per min)	
	Resting	Running
Kim	60	120
Dan	80	160

(b) Explain why Kim and Dan have higher heart rates while running. [1]

(c) Based on the information above, who is likely to be a smoker? Explain why. [2]

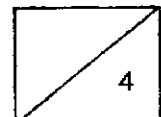

(Go on to the next page)

33 The diagram below shows three cells X, Y and Z.

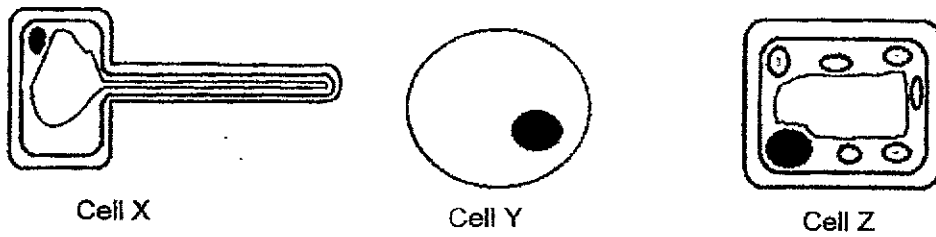

(a) Identify one part of a cell which can be found in all three cells and state its function. [1]

(b) The diagram below shows a magnified view of cell X. Cell X has a long structure and can be found in the roots of a plant.

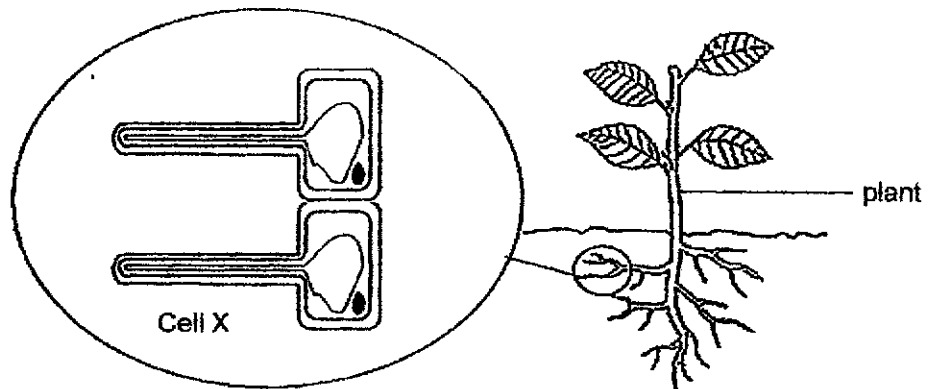

Based on the diagram above, explain how a longer structure helps to promote healthy plant growth. [2]

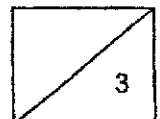

(Go on to the next page)

- 34 Louisa conducted an experiment to find out how the breathing rate of a fish is affected by the temperature of water. She placed a fish in a tank filled with water as shown in Figure 1.

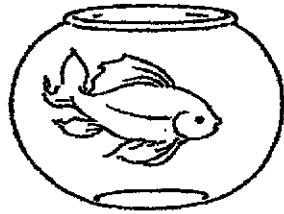

Figure 1

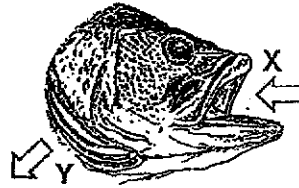

Figure 2

- (a) Figure 2 shows the flow of water from X to Y during the breathing process of a fish. Compare the amount of carbon dioxide at X and Y and write in the table below if the gas is 'more' or 'less' at X and Y. [1]

	X	Y
carbon dioxide		

To measure its breathing rate, Louisa counted the number of times the fish flapped its gills in one minute. She repeated the experiment using different temperatures of water and recorded the results as shown below.

	Temperature of water (°C)					
	20	22	24	26	28	30
Breathing rate (per min)	90	117	122	130	115	98

- (b) State the relationship between the breathing rate of the fish and the temperature of water. [2]

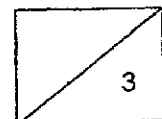

- 35 The diagram shows how water and substance P flow through different parts, A, B, C and stem of a plant.

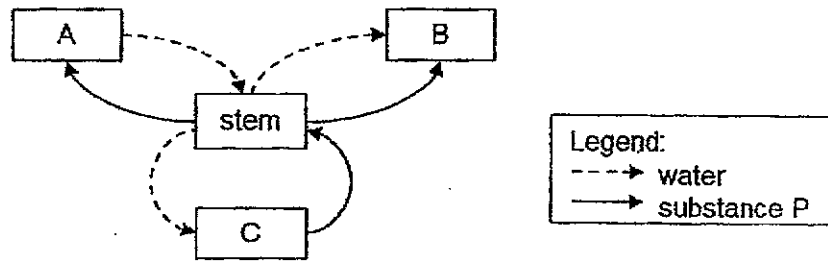

- (a) Which letters represent the plant parts below? [1]

Flower: _____

Leaf: _____

A part of a celery stalk was removed at X and Y as shown below. The stalk was then lowered into a beaker containing water with blue dye. After one day, the celery stalk was removed from the beaker and cut horizontally at two positions A and B.

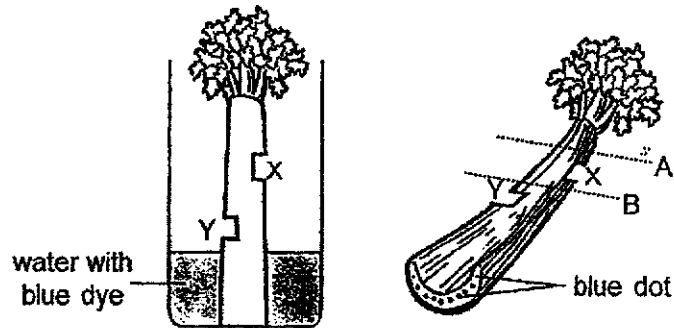

- (b) Two cross-sections of the cut surfaces are shown in the diagrams below. Fill in the blanks with 'A' or 'B' to indicate which part of the stalk they are cut from. [1]

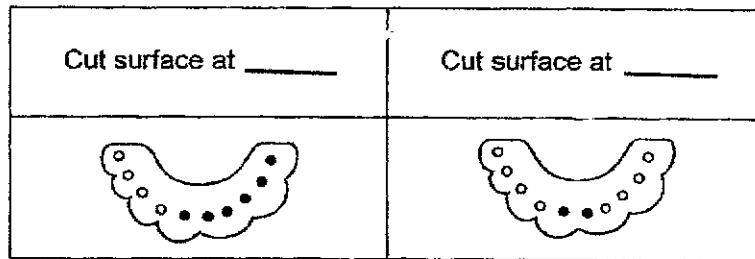

- (c) Explain your answer for the cut surface at A. [1]

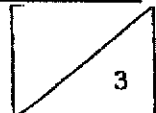

(Go on to the next page)

- 36 Kathy set up the experiment as shown below.

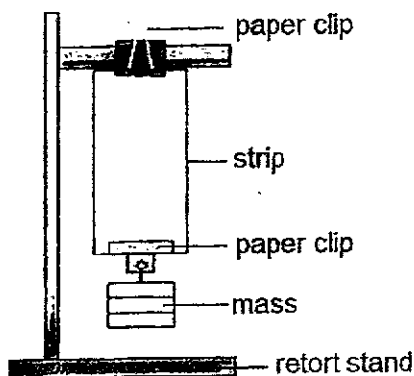

She clipped strips of materials, A, B and C, of the same size on a retort stand and added mass until the strips tore. The results are as shown in the table below.

Strips of material	A	B	C
Mass hung before strip tore (g)	400	350	500

- (a) State two variables of the materials that Kathy should keep the same. [1]

- (b) Kathy said material A is the strongest. Do you agree with her conclusion? Explain your answer. [1]

- (c) Material A was made into milk carton. It can be folded easily so that it can be thrown into the recycling bin without taking up too much space.

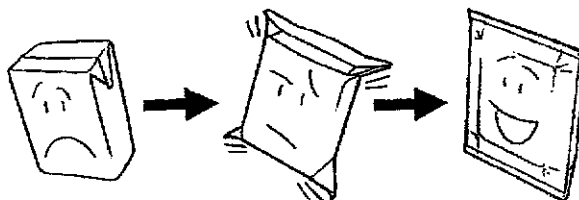

Apart from strength, state two other properties that that must be considered for the choice of material to be made into milk cartons. [1]

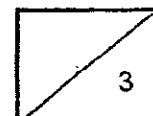

(Go on to the next page)

- 37 Zakiah conducted an experiment using the set-ups shown. The two beakers were identical and contained hot water at the same temperature.

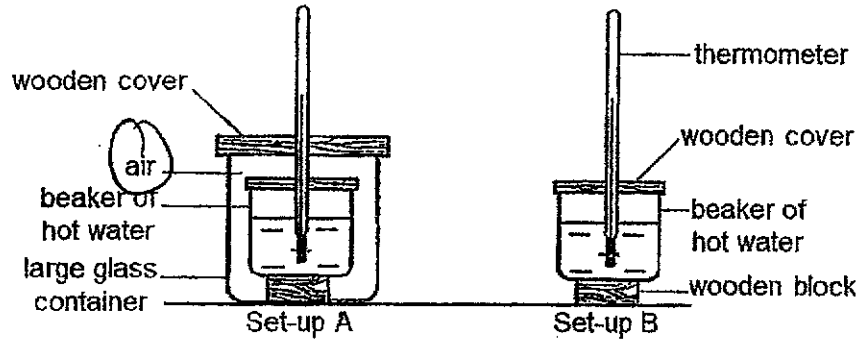

- (a) After some time, Zakiah found that the temperature of water in set-up A was higher than that in set-up B. Explain why. [2]

Zakiah wore a jacket when she visited the Snow City.

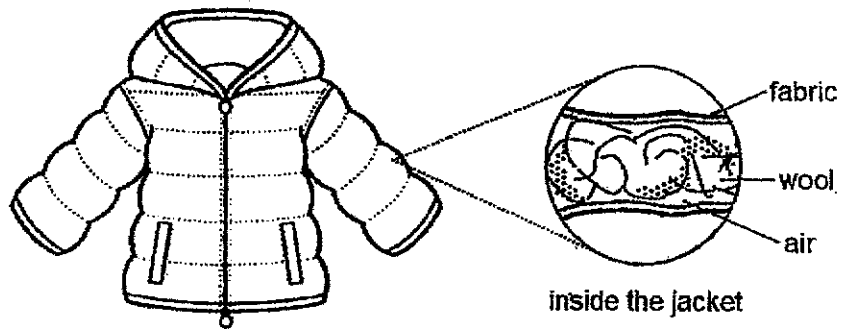

The jacket is made of fabric and filled with wool.

- (b) Describe how the jacket kept Zakiah warm. [2]

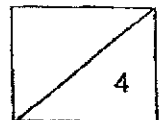

(Go on to the next page)

- 38 Mr Lin made two holes at K and L in a bottle and pushed down the bottle slowly into a basin of water as shown below.

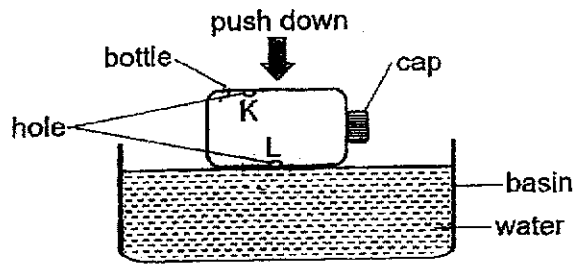

- (a) Explain why the bottle sank after a while.

When the submarine is at the sea surface, its ballast tanks are filled with air. To submerge, the ballast tanks are filled with water.

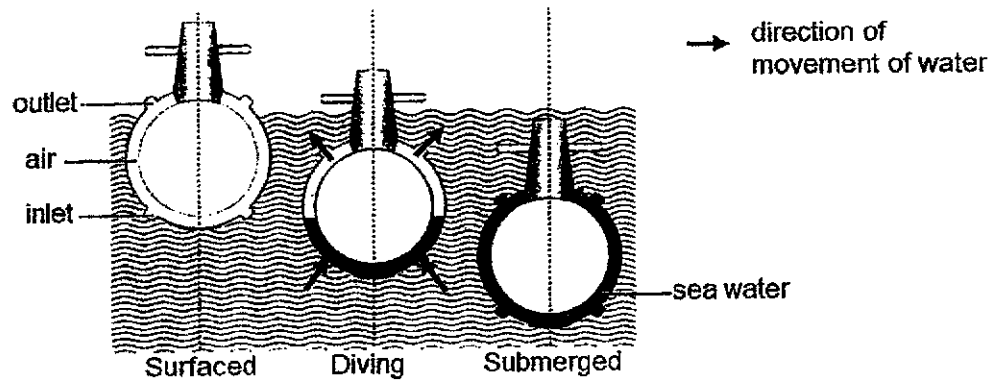

- (b) Describe how the ballast tank helps the submarine surfaced at sea to be submerged in the sea. [2]

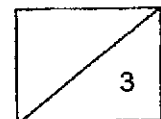

- 39 A hawker sold fried noodles at a night market. A mist was seen above the fried noodles as shown below.

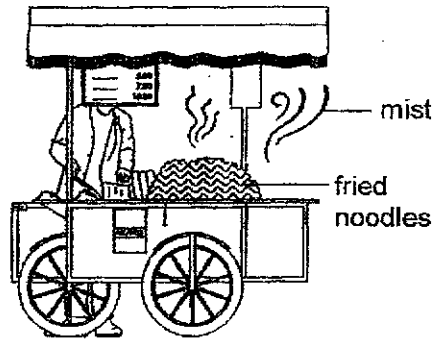

- (a) Explain how the mist was formed. [2]

- (b) The mist disappeared after some time. Explain why. [1]

- (c) Would the hawker see more or less mist on colder nights? Explain your answer. [1]

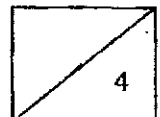

- 40 Mrs Wong set up a doorbell that will light up and make a 'ding' sound as shown below. The electric circuit and steel bars are fixed in place. When the iron strip moves towards the bell, the hammer will hit the bell to produce a 'ding' sound. The spring is fixed to the other end of the iron strip to pull it back to its original position after the hammer hits the bell.

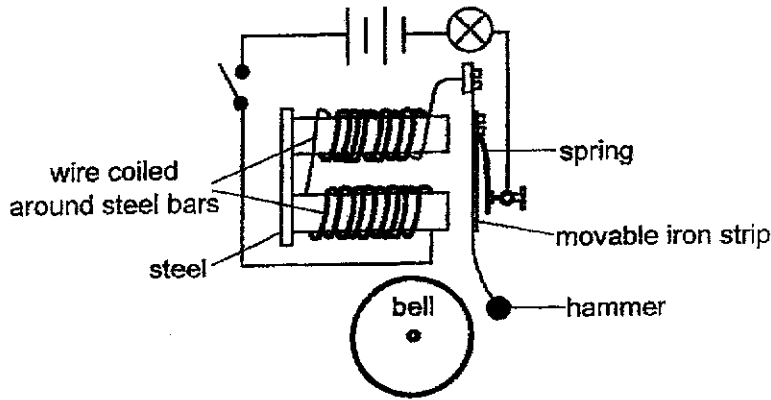

- (a) Explain how the doorbell works as described when Mrs Wong closed the switch. [2]

- (b) Suggest a change to the set-up if she wants to produce a softer 'ding' sound. [1]

- (c) She observed that when the bulb is fused and she closes the switch, there was no 'ding' sound. Explain why. [1]

- (d) Using the same circuit components, draw a circuit diagram to complete the set-up below to allow the doorbell to produce a 'ding' sound even when the bulb is fused. [1]

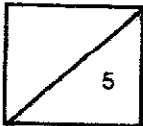
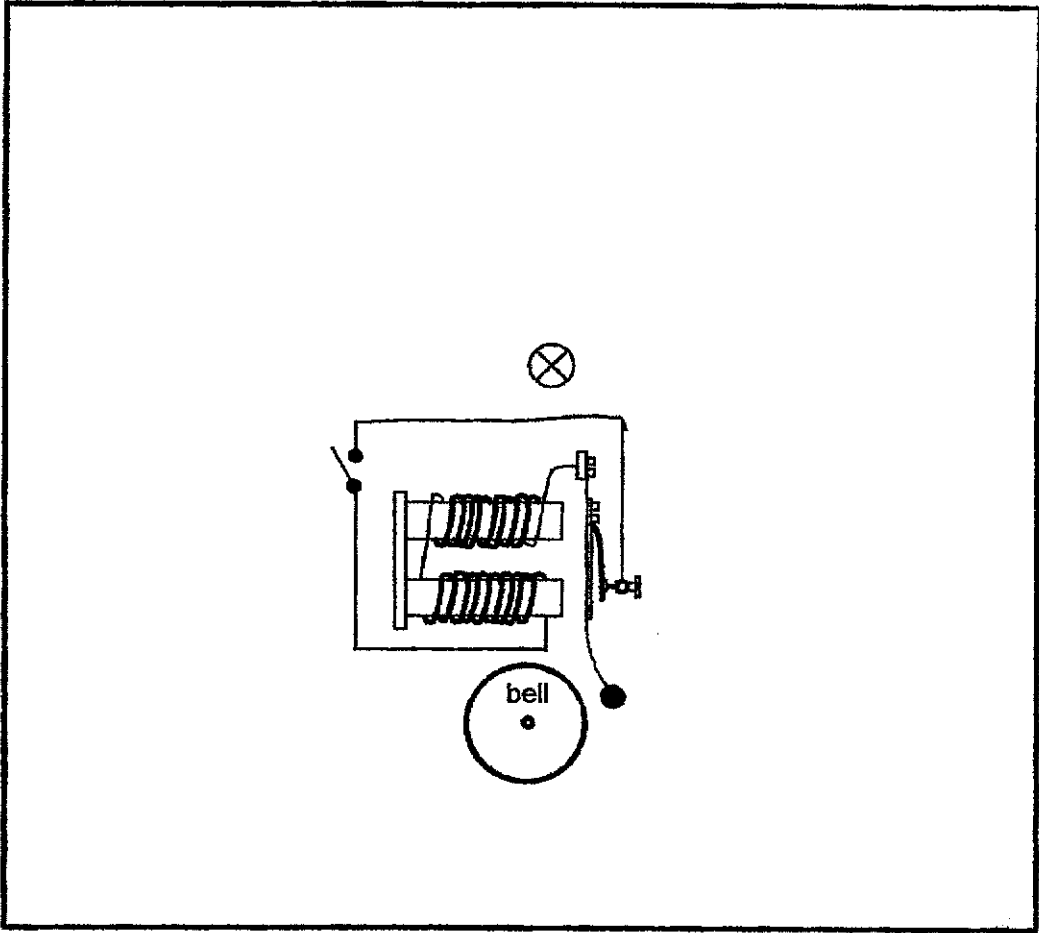

ANSWER KEY

YEAR : 2024
LEVEL : PRIMARY 5
SCHOOL : MGS
SUBJECT : SCIENCE
TERM : EOY

Q1	2	Q2	4	Q3	3	Q4	4	Q5	4
Q6	2	Q7	2	Q8	4	Q9	1	Q10	1
Q11	1	Q12	3	Q13	2	Q14	4	Q15	2
Q16	2	Q17	3	Q18	3	Q19	2	Q20	3
Q21	3	Q22	1	Q23	3	Q24	3	Q25	3
Q26	2	Q27	4	Q28	1				

35c	Water-carrying tubes were cut off/ removed at X and Y so the water with blue dye was transported through the few water-carrying tubes in the centre/ middle of the stem.
36a	Length/ Size/ Surface / Width/ / Mass/ Weight/ Shape of material.
36b	No, material C is the strongest as it could hold more/ most/ greatest amount of mass than material A before it tore. OR Material A did not hold the most amount of mass before it tore so it is not the strongest.
36c	Waterproof and flexible.
37a	Air in the large glass container is a poor conductor of heat so the beaker of hot water in set-up A loses heat slower to the surroundings. OR The beaker of hot water in set-up B loses heat faster to the surrounding without a layer of air which is a poor conductor of heat, surrounding it.
37b	There are air spaces between the fabric and wool and air is a poor conductor of heat. Zakiah's body lost heat slower to the surrounding air.
38a	Water entered the bottle through hole L while air escaped through hole K. The water occupied more space in the bottle slowly, causing the bottle to sink as it became heavier.
38b	Sea water enters into the ballast tank through the inlets while air is pushed out from the outlets. As the water occupies more space in the tank, it makes it heavier and causes it to sink and become submerged.
39a	Warm water vapour (above/ near the hot noodles) came into contact with the cooler surrounding air, lost heat and condensed into water droplets, forming the mist.
39b	The mist evaporated.
39c	More mist. More warm water vapour would lose heat to the colder surrounding air at night and condense into more water droplets.
40a	When she closed the switch, there is a closed circuit and electricity flows through the circuit and the bulb lights up. The steel bars are magnetized/ become electromagnets and attract the iron strip, causing the hammer to hit the bell.
40b	Remove one battery OR Decrease the number of coils of wire around the steel bars.
40c	The bulb is connected in series and there is an open circuit so no electricity can flow through the circuit.
40d	

3
END

Methodist Girls' School (Primary)
P5 Science EOY Examination 2024
Suggested Answers

Section B:

29a	Part Y absorbs water from the undigested food.
29b	Part Z of a person with disease Q has a smaller surface area in contact with digested food, so the rate of absorption of digested food is slower.
29c	The heart pumps blood containing digested food to other parts of the body through the blood vessels.
30a	The flowers will attract more insects/bees to pollinate the flowers and there is a higher chance of fertilization taking place so that more fruits can be produced.
30b	Animals eat and spit/ throw out the seeds which cannot be digested further away from the parent plant. OR Animals eat and pass out the seeds in its wastes further away from the parent plant.
30c	It is to reduce overcrowding so that the young plants will not need to compete with the parent plant or other young plants for sunlight, space, water and minerals.
31a	Graph Y. As the seed leaves provide food for the young plant/ seedling before its leaves develop to make food for itself.
31b	They reproduce by spores.
31c	Organism A feeds on dead matter/ other living things while organism B makes its own food.
32a	Blood vessel S. S has the most amount of carbon dioxide in the blood. Carbon dioxide in the blood is carried or transported from the rest of the body to the heart, and to the lungs where it is removed.
32b	The heart pumps blood faster to carry blood rich in oxygen and digested food to the body while running.
32c	Dan. His heart rate is higher when resting and running as his blood vessels are narrower and have less surface area exposed to the blood, so the blood vessels allow less blood containing oxygen to flow through/ the blood vessels allow blood to flow through slower.
33a	Cell membrane. It controls the movement of substances entering or leaving the cell. OR Nucleus. It controls all activities in the cell.
33b	A longer structure increases the surface area of the roots to water to help the plant take in more water. OR A longer structure enables the roots to grow deeper to reach for more water needed for survival.
34a	X: less Y: more
34b	As the temperature of water increases from 20°C to 26°C, the breathing rate of the fish increases. As the temperature of water increases from 26°C to 30°C, the breathing rate of the fish decreases.
35a	Flower: B Leaf: C
35b	B, A