



Rosyth School
Term Assessment 2024 (Term 1)

SCIENCE

Primary 6

Total

Marks:

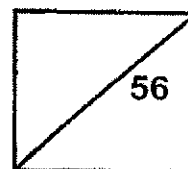

Name: _____

Class: Pr 6- _____ Register No. _____

Date: 29 February 2024

Duration: Total time for Booklets A and B: 1 h 45 min

Booklet A

Instructions to Pupils:

1. Please do not turn this page until you are told to do so.
2. Follow all instructions carefully.
3. Answer all questions.
4. This paper consists of 2 booklets, Booklet A and Booklet B.
5. For questions 1 to 28 in Booklet A, shade the correct ovals on the Optical Answer Sheet (OAS) provided using a 2B pencil.

This booklet consists of 20 printed pages (including cover page).

For each question from 1 to 14, four options are given. One of them is the correct answer. Make your choice (1, 2, 3 or 4). Write the correct answer in the OAS provided.

(56 Marks)

-
- 1 Which one of the following characteristics can be used to differentiate between a reptile and a bird?
- (1) The way they breathe
 - (2) The way they reproduce
 - (3) The number of body parts
 - (4) The type of outer covering
- 2 All plants _____.
- (1) reproduce by seeds
 - (2) make their own food
 - (3) bear flowers and fruits
 - (4) need oxygen at night only
- 3 Which characteristic(s) can be used to classify a tomato plant, a bird nest fern and a mushroom into two groups?
- A: Ways of reproduction
 - B: Ways of obtaining food
 - C: Flowering or non-flowering plants
- (1) A only
 - (2) A and B only
 - (3) B and C only
 - (4) A, B and C

- 4 A group of living things was observed under a microscope over three days.

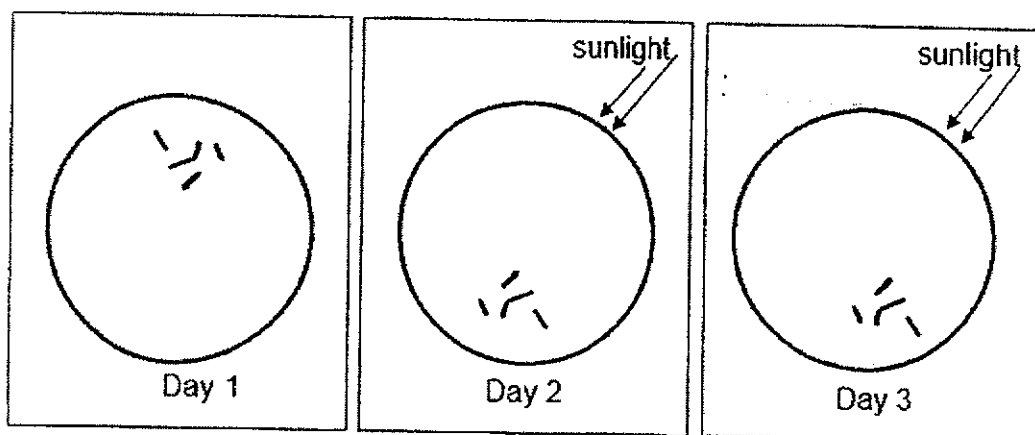

Which characteristic of living things was shown over the three days?

- (1) Living things can die.
 - (2) Living things can grow.
 - (3) Living things can respond.
 - (4) Living things can reproduce.
- 5 Many years ago, a scientist discovered an animal P and studied its characteristics. Some of the characteristics of animal P are as follows:

- A lays egg
- B has four legs
- C can swim in water
- D can produce milk to feed the young

Which of the above characteristics made it difficult to classify animal P as a mammal?

- (1) A
- (2) B
- (3) C
- (4) D

6 Observe the flow chart below.

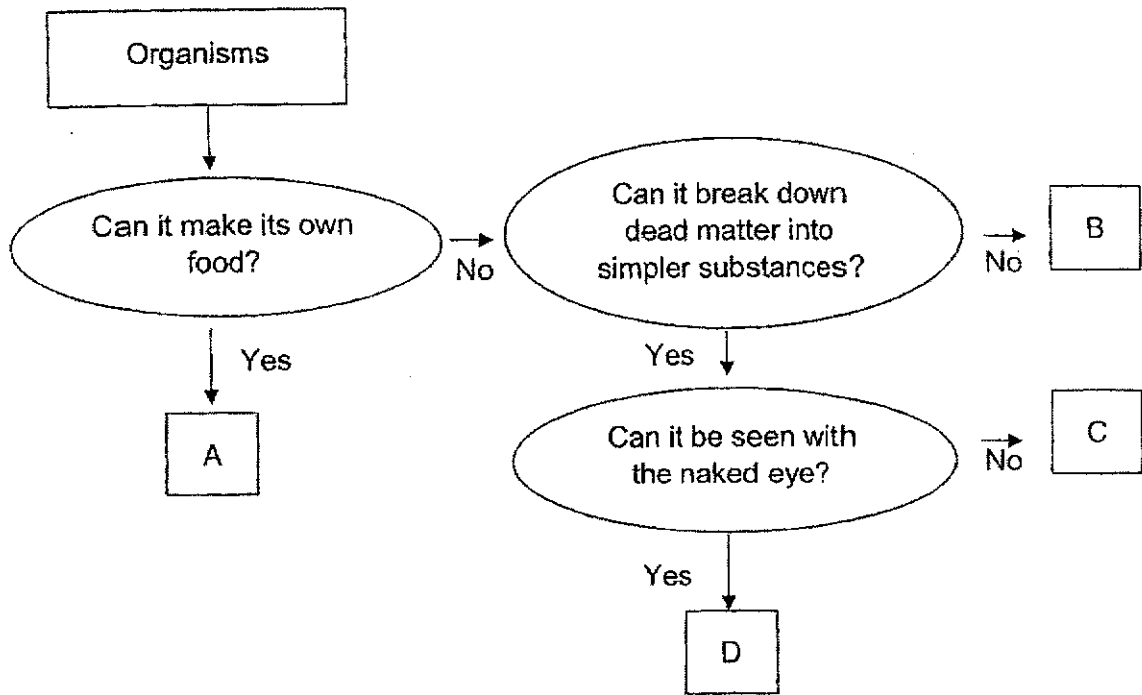

Which of the organisms above is likely a mushroom?

- (1) A
- (2) B
- (3) C
- (4) D

7 Study the life cycle of an animal.

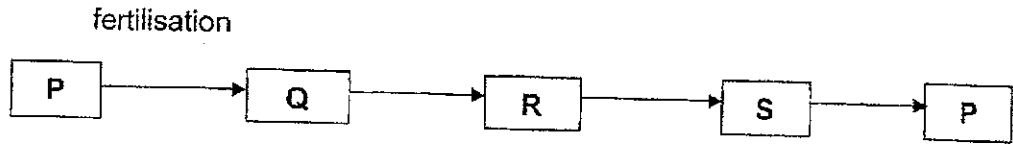

Which of the following correctly shows the animal and stage Q?

	Animal	Q
(1)	butterfly	egg
(2)	mosquito	adult
(3)	cockroach	adult
(4)	frog	egg

8 Study the classification chart below.

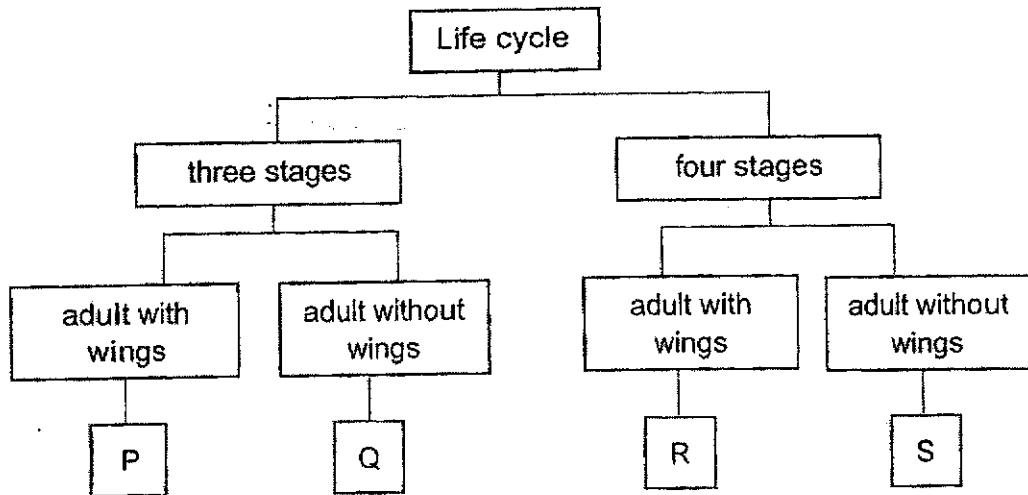

The diagram below shows the young and adult of insect A.



young

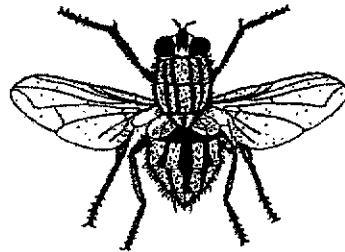

adult

Which group, P, Q, R or S, does insect A belong to?

- (1) P
- (2) Q
- (3) R
- (4) S

- 9 Han Wei carried out an experiment to find out if the temperature of the surroundings affects the life cycle of an organism. He recorded his observation in the table below.

Temperature of the surrounding (°C)	Number of days for one complete cycle
15	45
20	32
25	25
30	18

Which of the following conclusion is correct for Han Wei's experiment?

- (1) The organism does not survive at 30°C.
 - (2) The organism has four stages in its life cycle at 15°C.
 - (3) The organism takes a shorter time to complete one life cycle when the temperature of the surroundings is lower.
 - (4) The organism takes a longer time to complete one life cycle when the temperature of the surroundings is lower.
- 10 Which of the following statements about matter is/are true?

A: Matter has mass.

B: Matter occupies space.

C: Matter has a definite volume.

- (1) A only
- (2) B and C only
- (3) A and B only
- (4) A, B and C

11 Air is pumped into the balloon as shown below using an air pump.

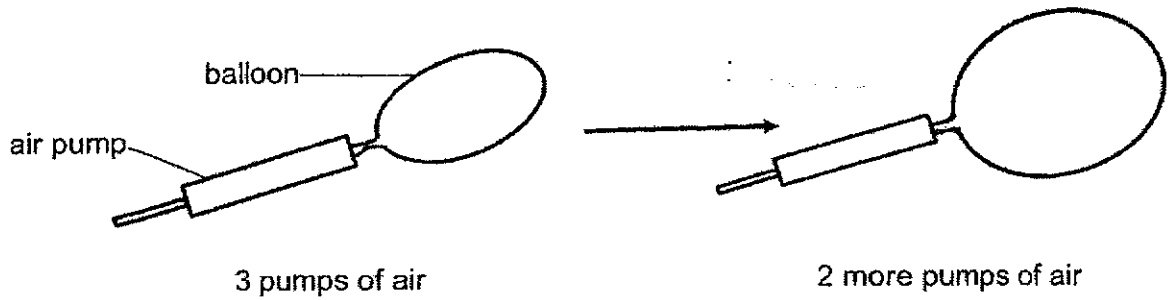

What happens to the total volume and the mass of air in the balloon after 2 more pumps of air is given?

	Total volume of air in the balloon	Total mass of air in the balloon
(1)	remains the same	increases
(2)	increases	increases
(3)	remains the same	remains the same
(4)	increases	remains the same

- 12 Ahmad was feeling cold as he was walking in a cool windy place. Then he sat down resting his bottom on a rock. Immediately, his bottom felt colder.

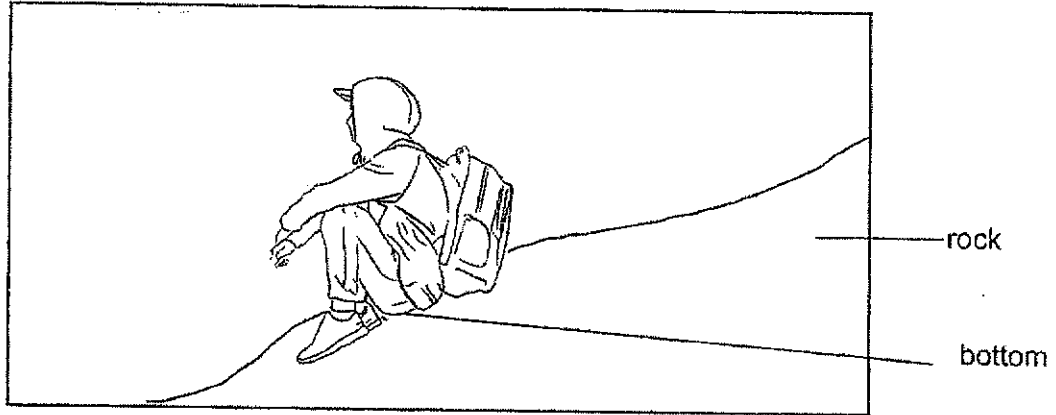

His bottom felt colder because it _____.

- (1) lost heat to the rock
- (2) did not gain heat from the rock
- (3) lost more heat to the surrounding air
- (4) is not exposed to the surrounding air

- 13 Two liquids, A and B, of the same amount, are first heated and left to cool in a classroom. The graph below shows the temperature of two liquids, A and B, during the cooling process.

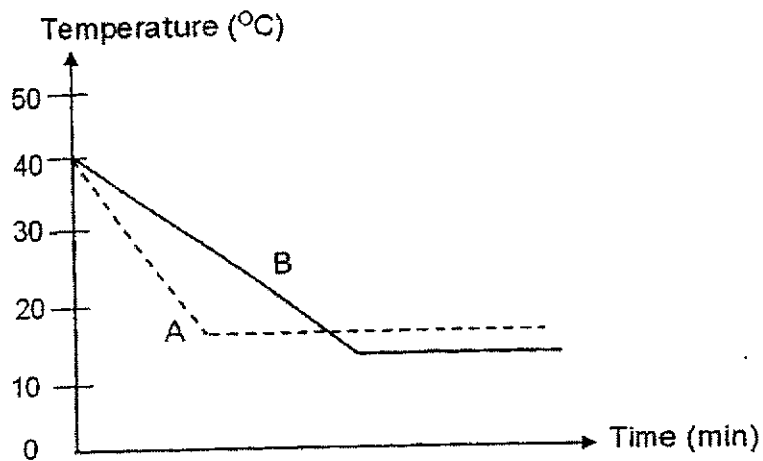

Which one of the following statements is true?

- (1) Liquid A boils at 40 °C.
- (2) Both liquids melt at 10 °C.
- (3) Liquid A has a higher boiling point than Liquid B.
- (4) The temperature of the classroom is below 20 °C.

- 14 There is a lighted candle and a toy behind a screen.

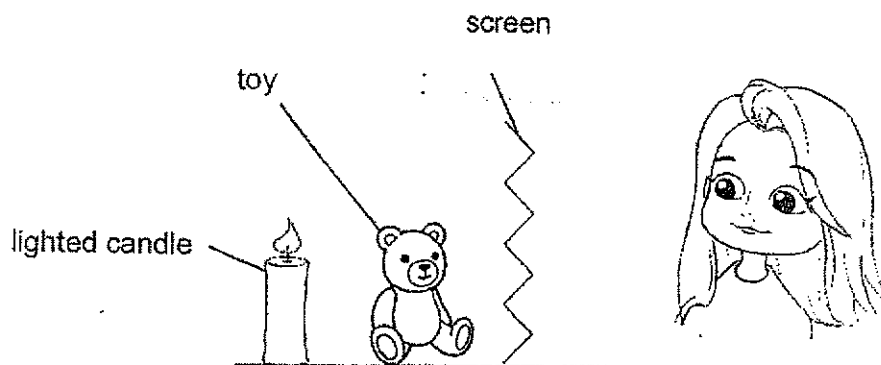

Which of the following explains why Nadiah cannot see the toy?

- (1) No light is entering Nadiah's eyes.
 - (2) The toy is not reflecting any light.
 - (3) Only some light can pass through the screen.
 - (4) No light is reflected from the toy into Nadiah's eyes.
- 15 Johnson listed some sources of energy and their forms of energy. Which one of the following is **not correct**?

	Source of energy	Form of energy
(1)	Battery	Electrical
(2)	Sun	Heat and Light
(3)	Food	Potential
(4)	Wind	Kinetic

- 16 Ravinder had two identical solid cylinders. He drilled a hole through one of the cylinders and made it hollow in the middle. Then he released both cylinders, hollow and solid, from the top of the ramp as shown below.

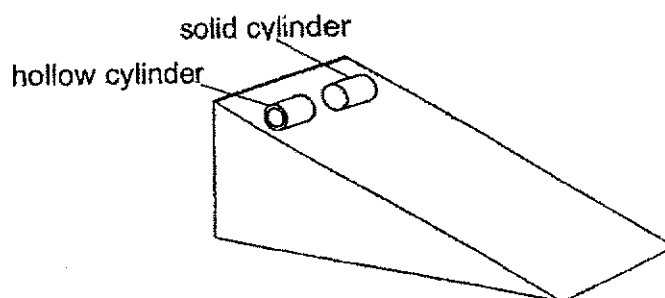

Which one of the following is the same for both the cylinders in the experiment?

- (1) Gravitational force acting on both cylinders.
 - (2) Potential energy possessed by the cylinders at the top of the ramp.
 - (3) Friction between the surface of the cylinders and the surface of the ramp.
 - (4) Kinetic energy possessed by the cylinders when the cylinders are resting on the ground.
- 17 Study the energy conversion below.

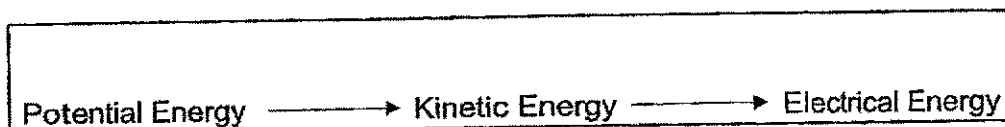

Which one of the following can represent the energy conversion correctly?

- (1) Using a handphone
- (2) Switching on a television
- (3) Spinning a bicycle dynamo
- (4) Typing on a computer keyboard

- 18 The table shows the percentage of useful energy released from three types of batteries, R,S, and T. Each battery is charged to 100 units.

Battery	Percentage of useful energy (%)
R	70
S	85
T	90

The batteries are used in similar electric cars to move them.

Using the information above, which statement is correct?

- (1) Battery T generates the most amount of heat energy.
- (2) Battery T will take the longest time to charge to 100 units.
- (3) Battery R converts the potential energy to least electrical energy.
- (4) Battery S will allow the electric car to travel more distance than Battery T.

19 A ball is thrown as shown below.

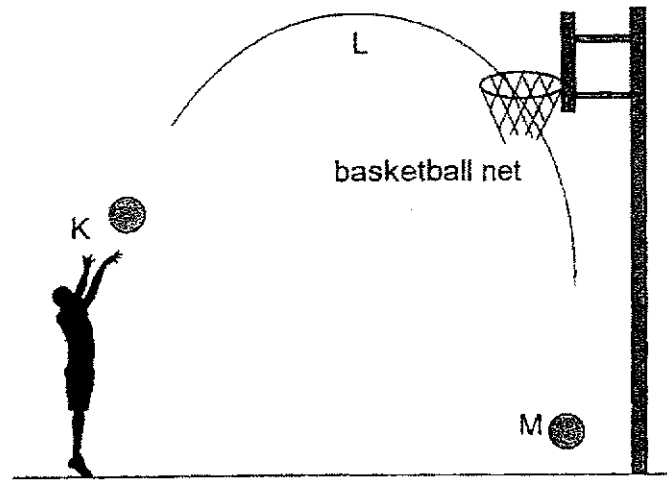

Which graph shows the kinetic energy of the ball at points K, L and M?

(1)

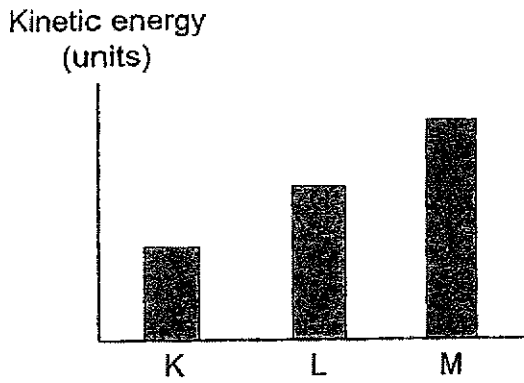

(2)

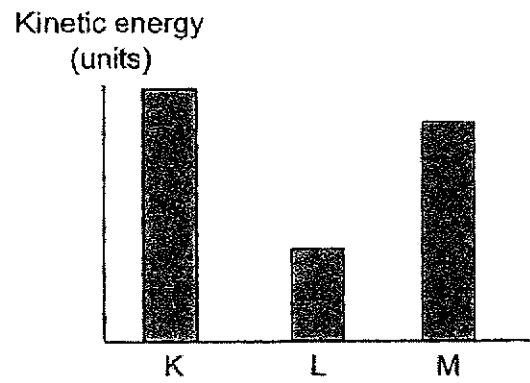

(3)

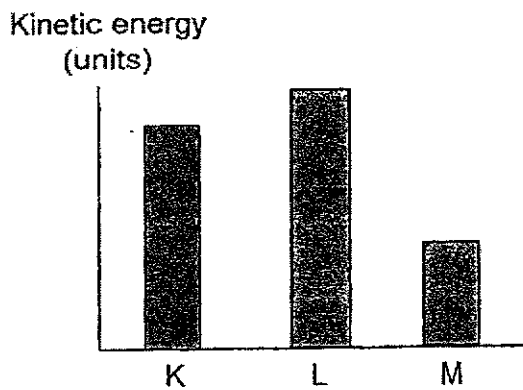

(4)

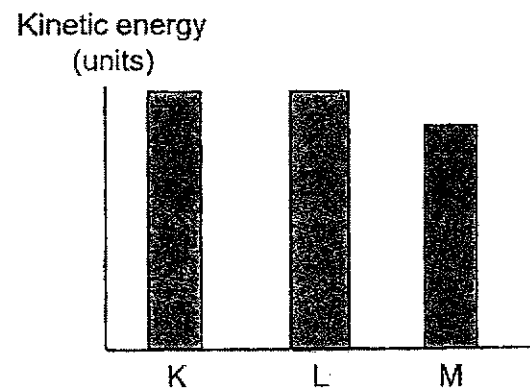

20 Study the diagram below.

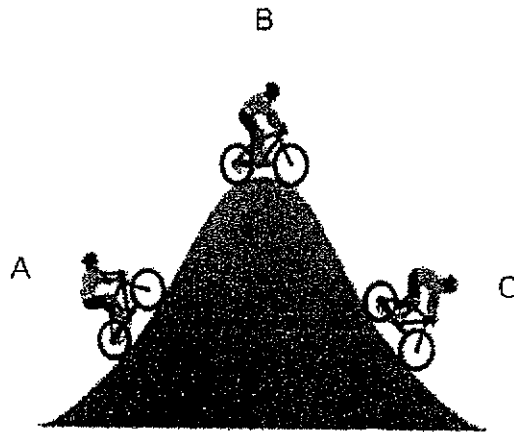

Energy conversion takes place as the cyclist moves from A to C. He stops at B for a minute before coming down.

Which one of the following shows the main form(s) of energy possessed by the cyclist as he moved from A to C respectively?

	A	B	C
(1)	Kinetic + Potential	Potential only	Kinetic only
(2)	Kinetic + Potential	Potential only	Kinetic + Potential
(3)	Kinetic only	Potential only	Kinetic + Potential
(4)	Kinetic + Heat	Potential + Kinetic	Kinetic + Heat

- 21 Keri was carrying a stack of books and a bouncy ball. As she was walking, the bouncy ball fell to the ground. When it hits the ground at B, the ball changes its shape and then it bounces to C.

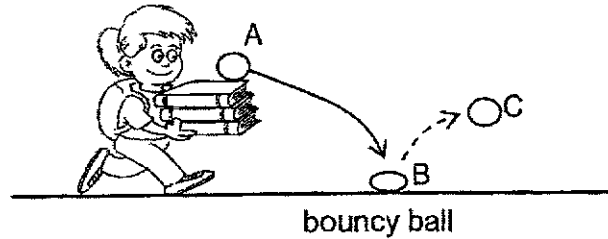

What is the energy conversion when the ball hits the ground at B?

- (1) kinetic \rightarrow sound + heat
 - (2) gravitational potential \rightarrow kinetic + sound
 - (3) kinetic \rightarrow heat + sound + elastic potential
 - (4) kinetic \rightarrow sound + heat + elastic potential
- 22 The diagram below shows a phone holder for a car. Material X is pasted on the phone cover. The phone with the cover is then safely secured on the phone holder in the car.

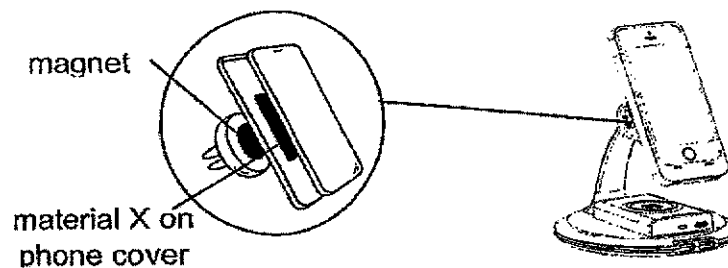

Which of the following statement is definitely correct?

- (1) Material X must be a magnet.
- (2) Material X cannot be a magnet.
- (3) Material X is made of a magnetic material.
- (4) Material X is made of non-magnetic material.

- 23 Zaki carried out an experiment with three different bars, X, Y and Z. The ends of the bars are labelled as shown.

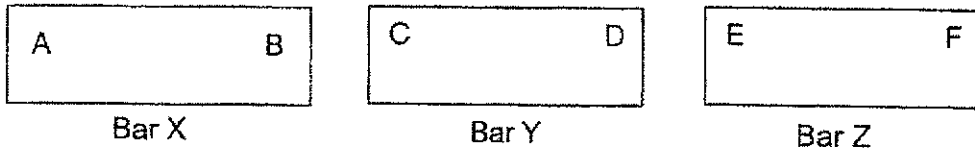

The table below shows how the bars interact when different ends of the bars are brought close to each other.

<div style="display: flex; justify-content: space-around; align-items: center;"> <div style="border: 1px solid black; padding: 5px;">A B</div> <div style="border: 1px solid black; padding: 5px;">C D</div> </div>	Repel
<div style="display: flex; justify-content: space-around; align-items: center;"> <div style="border: 1px solid black; padding: 5px;">A B</div> <div style="border: 1px solid black; padding: 5px;">D C</div> </div>	Attract
<div style="display: flex; justify-content: space-around; align-items: center;"> <div style="border: 1px solid black; padding: 5px;">A B</div> <div style="border: 1px solid black; padding: 5px;">E F</div> </div>	Attract
<div style="display: flex; justify-content: space-around; align-items: center;"> <div style="border: 1px solid black; padding: 5px;">A B</div> <div style="border: 1px solid black; padding: 5px;">F E</div> </div>	Attract

Based on the results given above, which of the following is definitely true?

- (1) Bar Z is made of steel.
- (2) Only bar Y is a magnet.
- (3) Bar X and bar Y are magnets.
- (4) Bar X and bar Z are not magnets.

- 24 Stacie throws a ball downwards to hit on the net. Then the ball bounces up after it has hit the net.

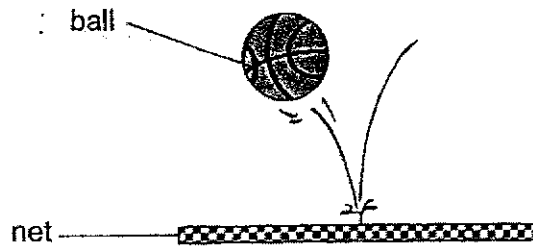

What force causes the ball to bounce up after it has hit the net?

- (1) pulling force from the ball
 - (2) pulling force from the net
 - (3) pushing force from the ball
 - (4) pushing force from the net
- 25 Which of the following is not an effect of force?

- (1) Change in state
- (2) Change in shape
- (3) Change in speed
- (4) Change in direction

- 26 A toy car is stationary on a slope as shown below.

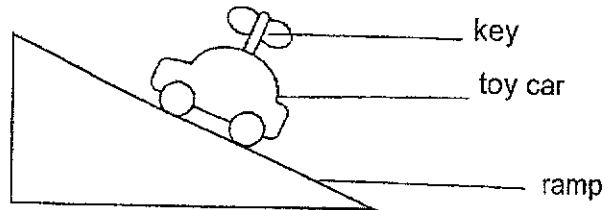

Which of the following is correct about the force acting on the toy car when it is stationary on the slope? _____ is acting on the toy car.

- (1) No force
 - (2) Only frictional force
 - (3) Only gravitational force
 - (4) Frictional and gravitational force
- 27 Simon wanted to move a box up a ramp. He pushed the box up the ramp but it did not move at all.

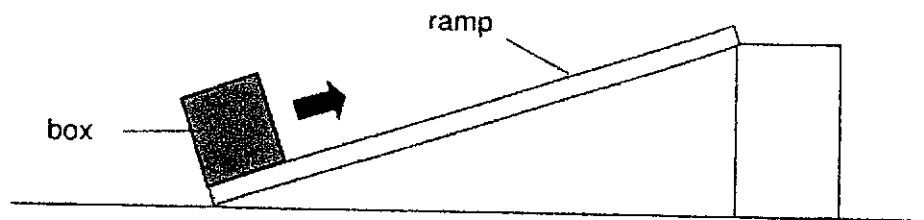

Why did the box not move up the ramp?

- (1) There was no force acting on the box.
- (2) A force smaller than the frictional force was applied.
- (3) Frictional force was acting upwards along the ramp.
- (4) Gravitational force was acting downwards along the ramp.

- 28 A group of students made a structure as shown below to drop an egg from a height without breaking the egg.

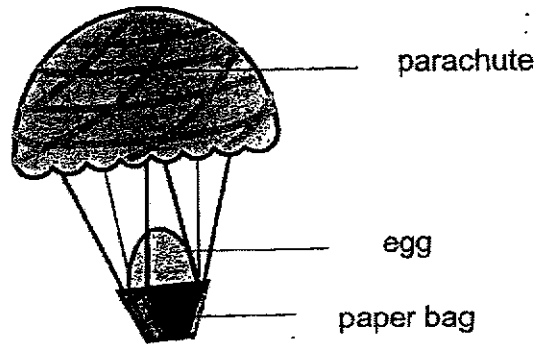

The structure helps to _____.

- (1) increase air resistance
- (2) decrease gravitational force
- (3) increase the speed at which it hits the ground
- (4) decrease the friction between the egg and the ground

Go to Booklet B



Rosyth School
Term Assessment 2024 (Term 1)
SCIENCE
Primary 6

Name: _____

Total
Marks:

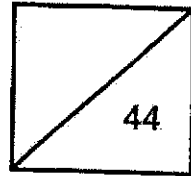

Class: Pr 6- _____ Register No. _____

Date: 29 February 2024

Parent's Signature: _____

Duration: Total time for Booklets A and B: 1 h 45 min

Booklet B

Instructions to Pupils:

1. Please do not turn this page until you are told to do so.
2. Follow all instructions carefully.
3. Answer all questions.
4. Use a dark blue or black ballpoint pen to write your answers in the space provided for each question.
5. Do not use correction fluid/tape or highlighters.

	Maximum	Marks Obtained
Booklet A	56 marks	
Booklet B	44 marks	
Total	100 marks	

* This booklet consists of 15 printed pages (including cover page).

For questions 29 to 41, write your answers in the space provided. (44 Marks)

29 The chart below shows a classification of living things.

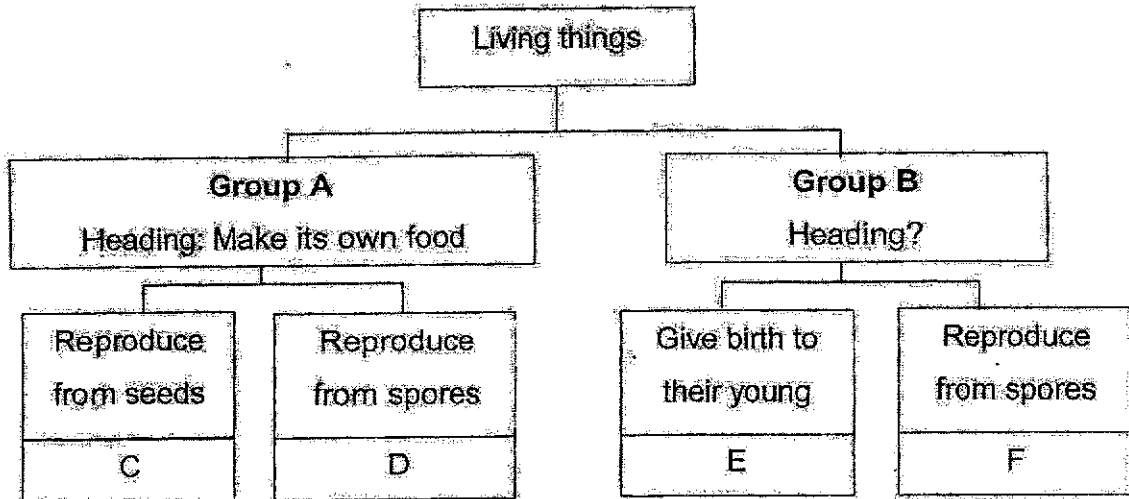

Do not write in the margin.

Do not write in the margin.

(a) Write a suitable heading for group B. [1]

Heading: _____

(b) Name an example for F. [1]

(c) State two ways group B depends on group A to stay alive. [2]

Do not write in the margin.

30 Neesha recorded her observations of some animals that she had found in a garden in the table below.

Animal	Number of legs	Number of wings
P	6	4
Q	8	0
R	2	2
S	6	0

(a) Based on the information given, Neesha is very certain that P and S are insects. Do you agree? Explain why. [1]

(b) Neesha wanted to draw a checklist to differentiate living things from non-living things. She has done one characteristic as shown in the table below. Complete the table below for (ii) with one more characteristic. [1]

Characteristics of living things	
i	They respond to changes.
ii.	

Do not write in the margin.

Do not write in the margin.

Do not write in the margin.

31 The diagrams show the life-cycles of two animals, A and B, living in a pond.

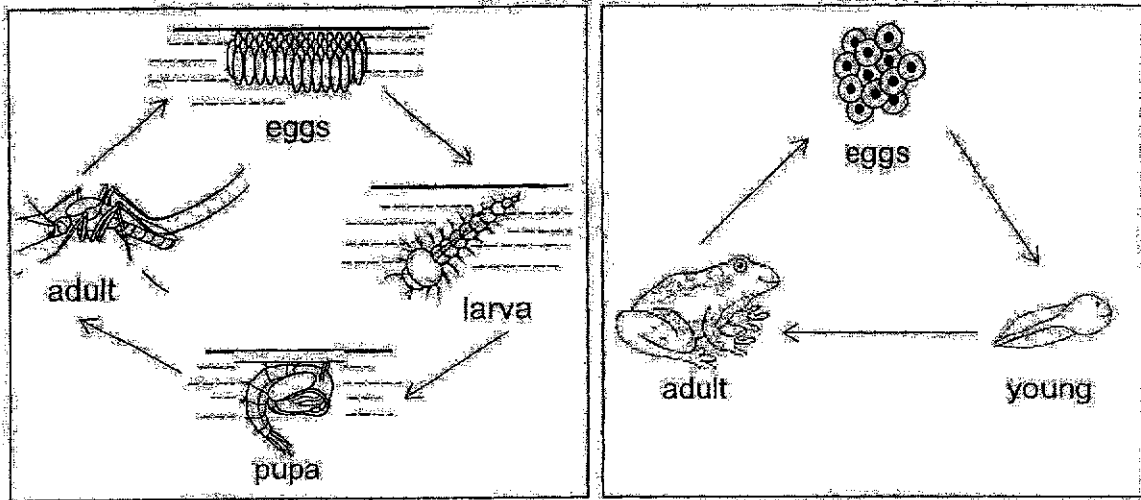

Do not write in the margin.

Do not write in the margin.

(a) State a difference between the two life cycles in terms of their stages. [1]

(b) Explain how laying many eggs helps both animals. [1]

Both the young of the frog and mosquito live in water.

(c) If the pond dries up due to hot weather, explain how this would prevent the frog and mosquito from reproducing. [1]

Do not write in the margin.

32 The diagram shows the life cycle of insect X.

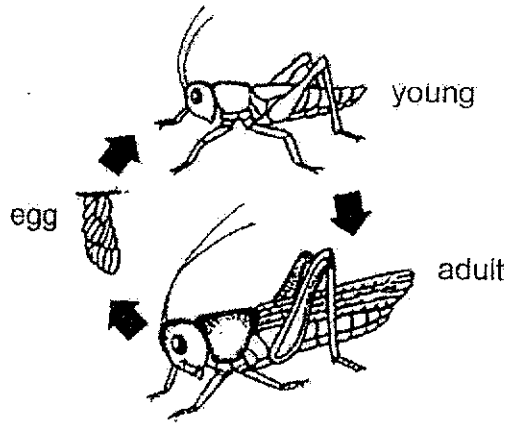

(a) Explain why life cycles are important. [1]

(b) Based on the diagram above, state one difference between the young and the adult of insect X (Do not mention size, shape and colour). [1]

(c) State one similarity between the life cycle of a cockroach and that of Insect X. [1]

(d) The table shows the effect of surrounding temperature on the life cycle of insect X.

Temperature (°C)	Number of days for one complete life cycle
10	45
20	33
30	28
40	17

State the relationship between the number of days for one complete life cycle of insect X and the surrounding temperature. [1]

Do not write in the margin.

Do not write in the margin.

Do not write in the margin.

33

(a) Draw and label the life cycle of a green plant in the box below.

[2]

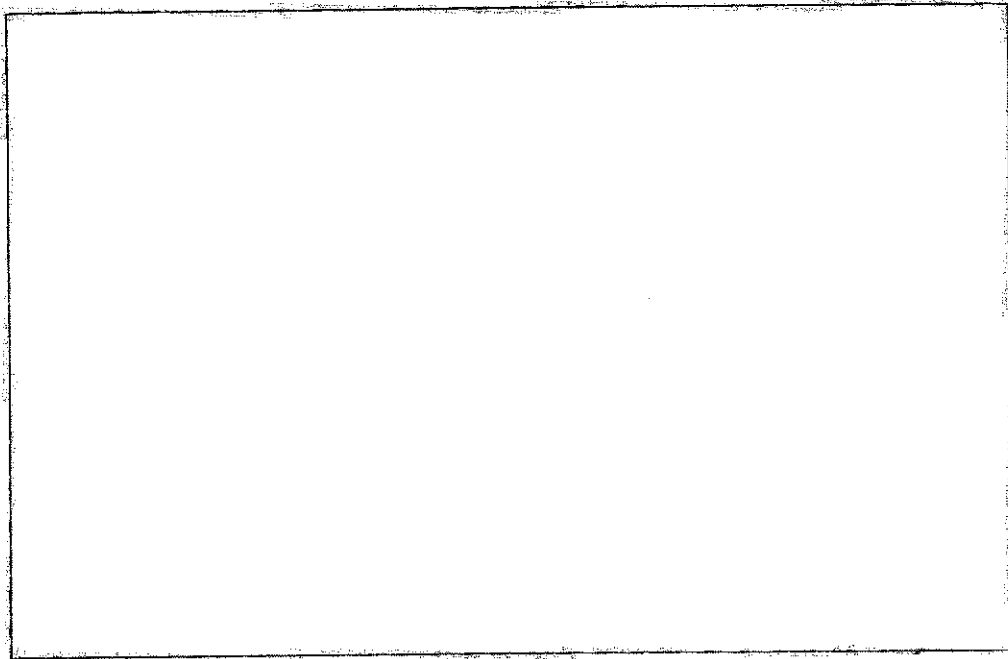

Do not write in the margin.

Do not write in the margin.

She plotted a graph to show the changes in the mass of its seed leaf over four days as shown in the graph below.

days as shown in the graph below.

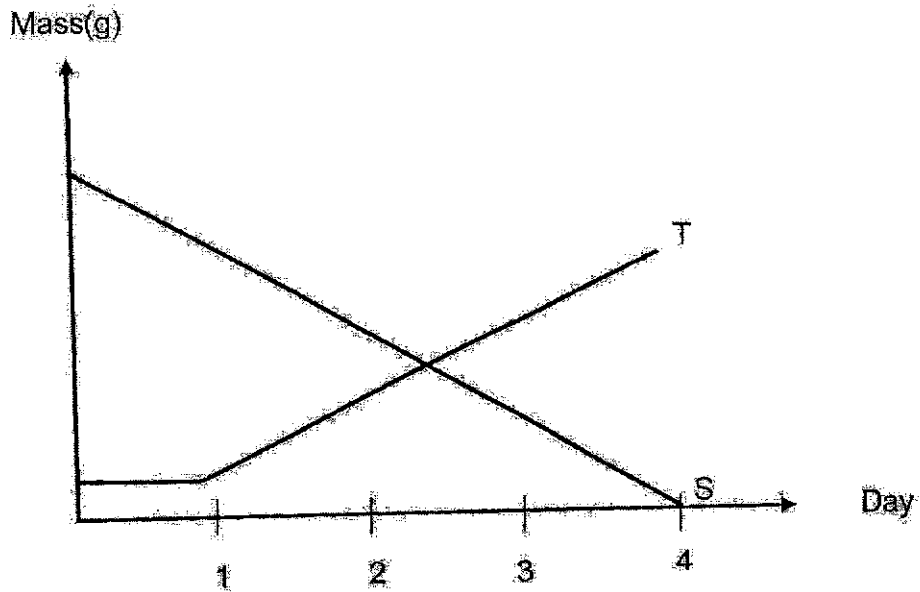

Question 32 continues on page 7

Do not write in the margin.

(b) Which line, S or T, best represents the mass of the seed leaf during the experiment. Explain your answer. [1]

(c) How does the plant continue to grow well from day 4 onwards? [1]

Do not write in the margin.

Do not write in the margin.

Do not write in the margin.

34 Paul wants to test the physical property of different materials. He pours 200ml water onto material X and measured the volume of water collected in the beaker below.

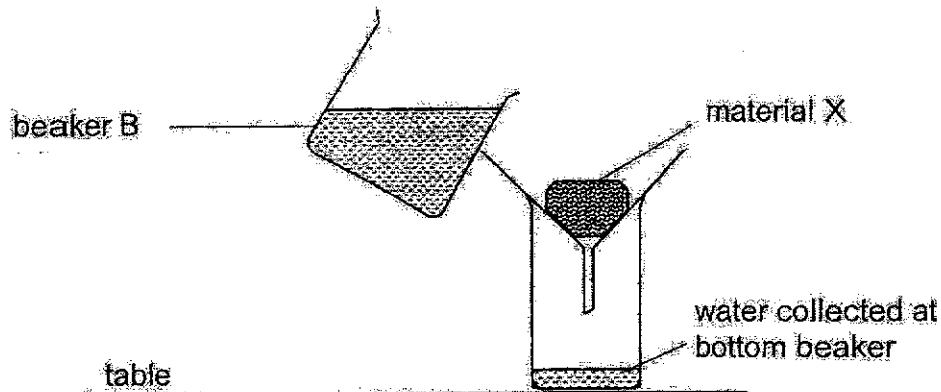

The procedure was repeated with materials Y and Z of similar size as material X. The volume of water collected was recorded.

Material	X	Y	Z
Volume of water collected at bottom beaker (ml)	180	170	200

(a) What physical property of the materials was Paul testing? [1]

(b) Paul pours the water gently from beaker B to prevent water from splattering when it hits the material. What else should he do to ensure that the water hits materials, X, Y and Z, with same amount of force? [1]

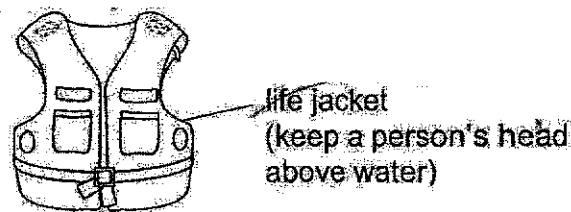

(c) Which material, X, Y, or Z, is the most suitable to make a life jacket? Explain your answer. [2]

Do not write in the margin.

Do not write in the margin

Do not write in the margin.

- 35 The diagram shows a washing machine. When the door is closed and the machine is turned on, an electric motor rotates the drum for washing.

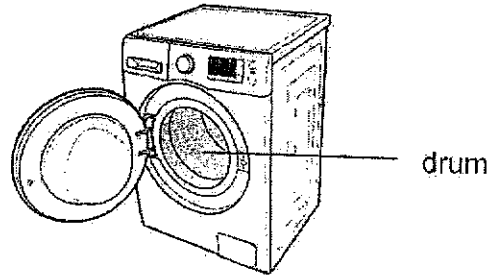

- (a) State the energy conversions to wash the clothes. [2]

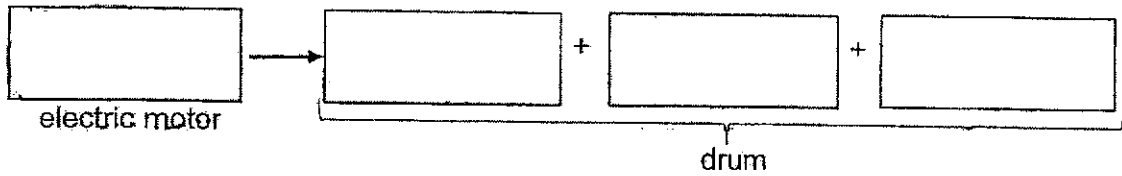

Study the graph below carefully.

Usage of energy per wash cycle (kWh)

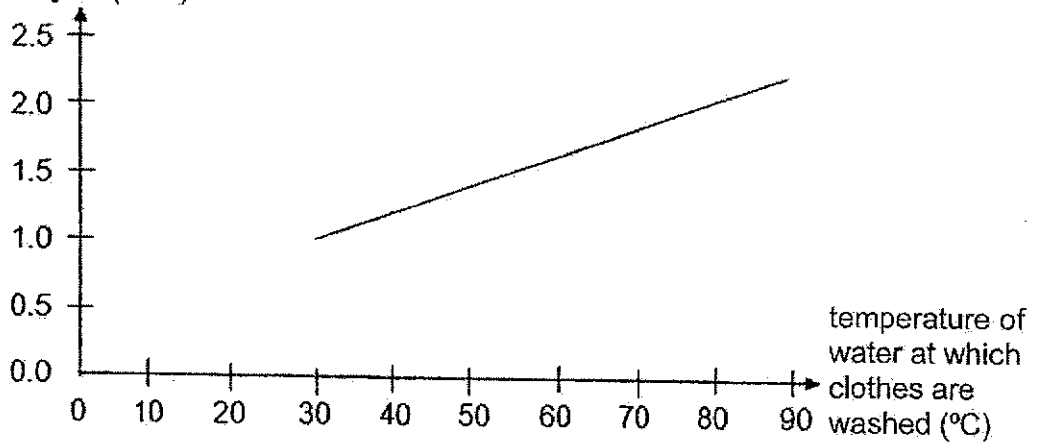

- (b) What is the relationship between the temperature of water at which the clothes are washed and the usage of energy? [1]

- (c) Explain the relationship in (b) using energy conversion. [1]

Do not write in the margin.

Do not write in the margin.

Do not write in the margin.

36. Ali conducted an experiment using the set-up as shown below.

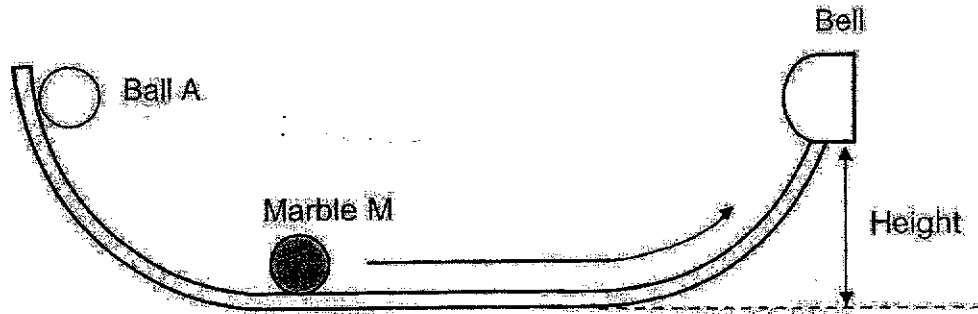

He wanted to find out the mass of the ball required to move marble M to hit the bell. Ball A was released to hit marble M. Marble M moved in the direction as shown in the set-up. He repeated the experiment with Balls B and C and recorded his results in the table below.

Ball	Mass of Ball (g)	Height moved by marble M	Did the bell ring?
A	150	50	Yes
B	120	45	No
C	90	40	No

Do not write in the margin.

Do not write in the margin.

(a) What is the relationship between the mass of the ball and the height moved by marble M? [1]

(b) The bell did not ring when Ball A was released from a lower position on the set-up. Explain this observation in terms of energy conversion. [2]

Do not write in the margin.

- 37 The diagram below shows a machine that is used to demolish buildings. The metal ball swings and hit the building to break it. The higher the ball swings, the greater the damage done.

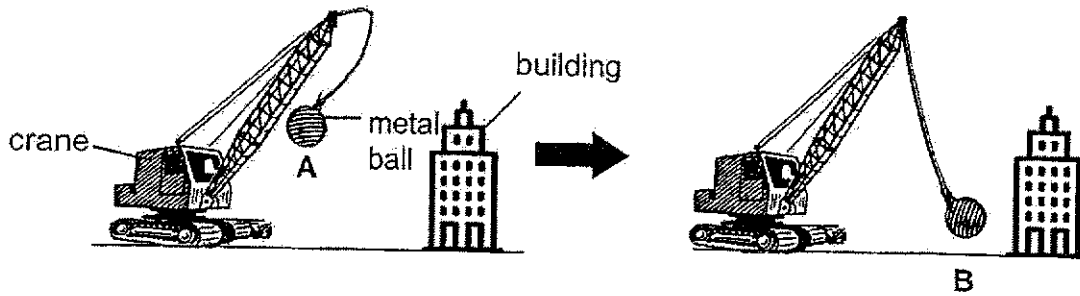

- (a) The metal ball is pulled backwards before it is released to hit the building. Fill in the boxes below to show the energy conversion as the metal ball is swung from positions A to B. [2]

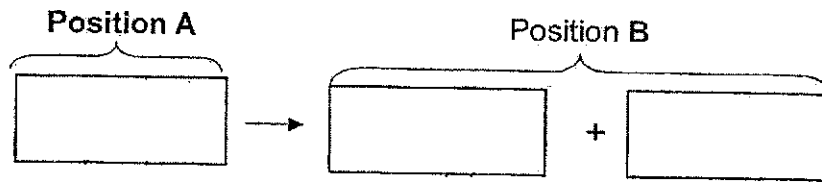

- (b) Explain how swinging the ball higher will cause more damage to the building. [2]

- (c) Other than swinging the ball higher, what change can be made to the ball to cause more damage to the building? [1]

Do not write in the margin.

Do not write in the margin.

Do not write in the margin.

38 A "Maglev" train is a special train that floats a few centimetres above the track while it is moving. This is made possible by the use of very strong magnets.

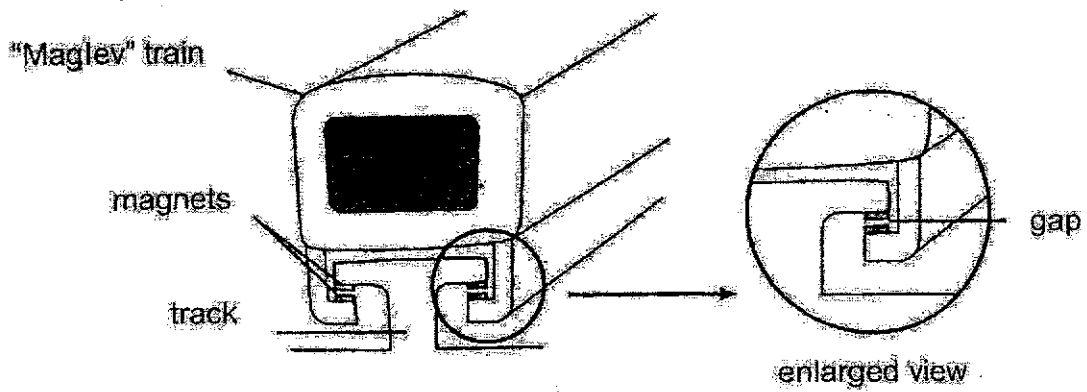

(a) Explain what causes the gap between the magnets. [1]

(b) Explain why "Maglev" trains travel much faster than normal trains. [2]

Do not write in the margin.

Do not write in the margin.

Question 38 continues on page 13

Do not write in the margin.

The "Maglev" train cannot hold beyond a certain amount of weight for it to function. Sasha made a model of a "Maglev" train as shown below.

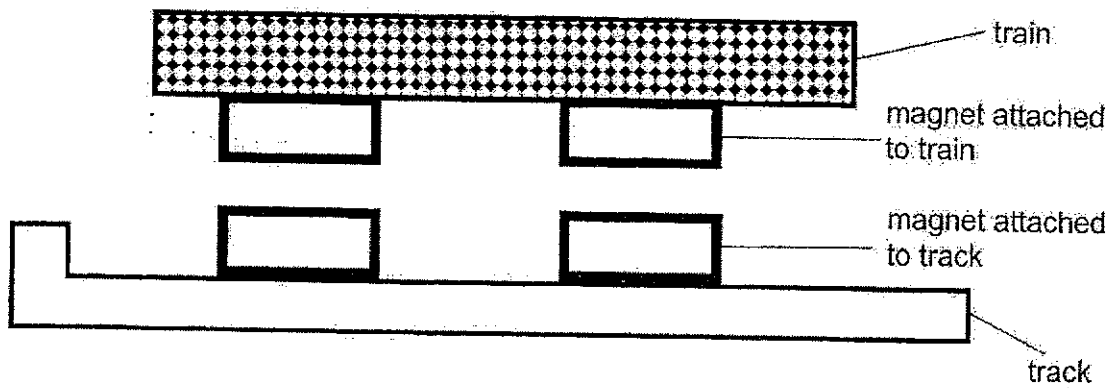

Model of "Maglev" train

- (c) Suggest what she should measure to find out the maximum weight the model train can hold. [1]

Do not write in the margin.

Do not write in the margin.

Do not write in the margin.

39 A man is trying to push a box as shown.

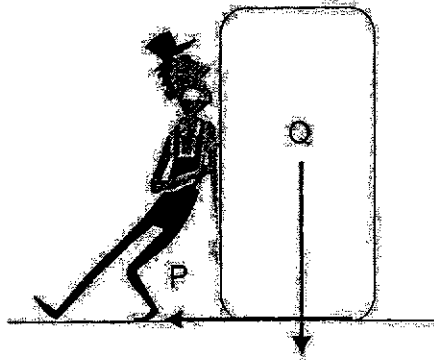

(a) Name the forces, P and Q, acting on the box. [2]

P: _____

Q: _____

(b) The man found that no matter how hard he pushed, he was not able to move the box. Explain why. [1]

(c) Suggest one way to help the man move the box easily in the direction as shown. [1]

Do not write in the margin.

Do not write in the margin.

Do not write in the margin.

40 Jun Xiang threw a piece of plasticine on a noticeboard as shown in the diagram below.

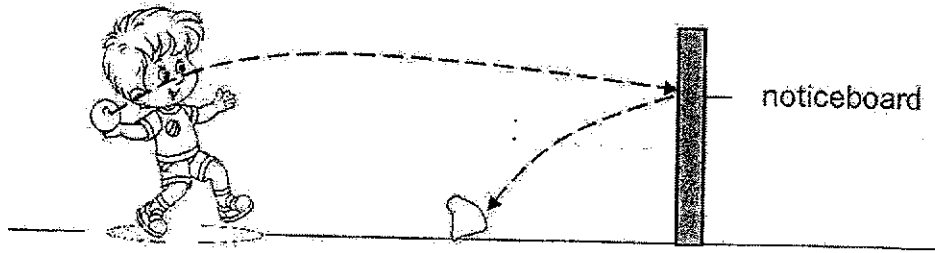

(a) Name the force that caused the plasticine to drop on the ground. [1]

(b) Give two effects of force on the plasticine caused by the throwing. [2]

Do not write in the margin.

Do not write in the margin.

End of Paper

Do not write in the margin.

SCHOOL : ROSYTH PRIMARY SCHOOL
LEVEL : PRIMARY 6
SUBJECT : SCIENCE
TERM : 2024 WA1

Q1	Q2	Q3	Q4	Q5	Q6	Q7	Q8	Q9	Q10
4	2	2	3	1	4	1	3	4	3
Q11	Q12	Q13	Q14	Q15	Q16	Q17	Q18	Q19	Q20
2	1	4	4	1	4	3	3	1	2
Q21	Q22	Q23	Q24	Q25	Q26	Q27	Q28		
2	3	3	4	1	4	2	1		

PAPER 2

Q29)	<p>a) Heading : Feed on other using things.</p> <p>b) Mould</p> <p>c) Group B can get food and oxygen from group A to stay alive.</p>
Q30)	<p>a) Yes, as only insects and all insects has six legs and P and S has six legs.</p> <p>b) li)They need air, food and water to survive.</p>
Q31)	<p>a) Animal A. has four stages in its life cycle while animal B has three stages in its life cycle.</p> <p>b) Some eggs may be eaten by predators or die, so that other eggs can be hatched and grow into adults.</p> <p>c) If the pond dries up, there would be no water for the young of the frog and mosquito to live.</p>

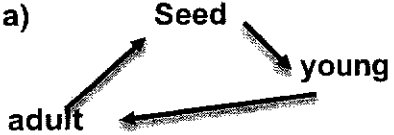
Q32)	<p>a) Life cycle are important so that we can understand the different stages of different life cycle and ensure the continuity of its kind.</p> <p>b) The adult of insect X has wings while the young of insect X does not have wings.</p> <p>c) Both life cycle of a cockroach and insect X has three stages in its life cycle.</p> <p>d) As the temperature increases, the number of days for one complete life cycle of insect X decreases.</p>
Q33)	<p>a) </p> <p>b) Line S, as the seed leaf provides food to the seedling, so its mass will decrease.</p> <p>c) From day 4 onwards, the plant would have grown green leaves. It will then make its own food from the green leaves.</p>
Q34)	<p>a) To test if the material was waterproof.</p> <p>b) The height between beaker B and material X should be the same, when he pours the water on the material.</p> <p>c) Material X Z as it did not absorb any water, so it is waterproof. When it did not absorb any water, it would be light and float above the water. Therefore making material Z the most suitable material as it will keep the person's head above the water.</p>
Q35)	<p>a) Electrical energy \rightarrow kinetic energy + sound energy + heat energy</p> <p>b) As the temperature of water at which clothes are washed increase, the usage of energy per wash cycle increases.</p> <p>c) As the temperature of water at which clothes are washed increase, the amount of electrical energy would increase so that more electrical energy could be converted to move heat energy.</p>
Q36)	<p>a) As the mass of the balls increase, the height moved by marble M increase.</p> <p>b) When ball A was released from a lower position, the ball will possess less potential energy which is converted to less kinetic energy when it is released.</p>

Q37)	<p>a) Gravitational potential energy \rightarrow kinetic energy + sound energy</p> <p>b) When the ball is higher, more gravitational potential energy will be converted to more kinetic energy. This would result in more force on the structure.</p> <p>c) Increase the mass of the metal ball.</p>
Q38)	<p>a) The poles of the magnets on the train and the poles of the magnets on the track are like poles facing each other, causing them to repel.</p> <p>b) The repulsion between the magnets under the train and above the track causes the decrease of friction between the train and the tracks.</p> <p>c) Measure the weight just before the distance between the train and track becomes zero.</p>
Q39)	<p>a) P: Frictional Force Q: Gravitational force</p> <p>b) The force he exerted on the box is not able enough to overcome the friction between the box and the floor.</p> <p>c) Add wheels at the bottom of the box.</p>
Q40)	<p>a) Gravitational force</p> <p>b) The change in shape of the plasticine and the change in speed of the plasticine.</p>

