



HENRY PARK PRIMARY SCHOOL  
2025 PRELIMINARY EXAMINATION  
MATHEMATICS  
PRIMARY 6

PAPER 1  
(BOOKLET A)

Name: \_\_\_\_\_ ( )

Parent's Signature

Class: Primary 6 \_\_\_\_\_

\_\_\_\_\_

Marks:

Paper 1	Booklet A	20
	Booklet B	25
Paper 2		55
<b>Total</b>		<b>100</b>

Total Time for Booklets A and B: 1 hour

Do not turn over this page until you are told to do so.

Follow all instructions carefully.

Answer all questions.

Shade your answers in the Optical Answer Sheet (OAS) provided.

You are not allowed to use a calculator.

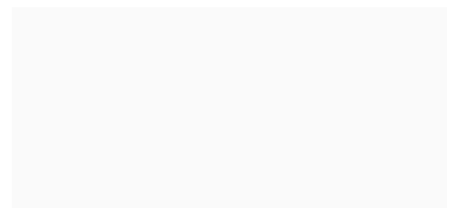

Questions 1 to 10 carry 1 mark each. Questions 11 to 15 carry 2 marks each.  
For each question, four options are given. One of them is the correct answer.  
Make your choice (1, 2, 3 or 4) and shade your answer in the Optical Answer Sheet.

(20 marks)

1 Round 309 499 to the nearest thousand.

- (1) 300 000
- (2) 309 000
- (3) 309 500
- (4) 310 000

2  $70 + \frac{7}{10} + \frac{7}{100} = \boxed{\quad ? \quad}$

What is the missing number in the box?

- (1) 70.077
- (2) 70.77
- (3) 77.07
- (4) 77.7

3 Find the value of  $72 - 4 \times 3 + 24$

- (1) 1836
- (2) 228
- (3) 84
- (4) 36

4 A musical started at 18 35 and ended at 20 20. What was the duration of the musical?

- (1) 105 min
- (2) 115 min
- (3) 145 min
- (4) 185 min

- 5 The table shows the number of students who wear and do not wear spectacles.

	Wear spectacles	Do not wear spectacles
Boys	5	2
Girls	15	3

What percentage of the students do not wear spectacles?

- (1) 60%  
 (2) 25%  
 (3) 20%  
 (4) 5%

- 6 The net of a cube is shown. Which 2 faces are opposite each other?

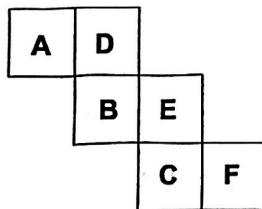

- (1) A and B  
 (2) B and E  
 (3) D and F  
 (4) C and D

- 7 SX, TW, ZU and YV are straight lines. Which pair of angles does not add up to  $180^\circ$ ?

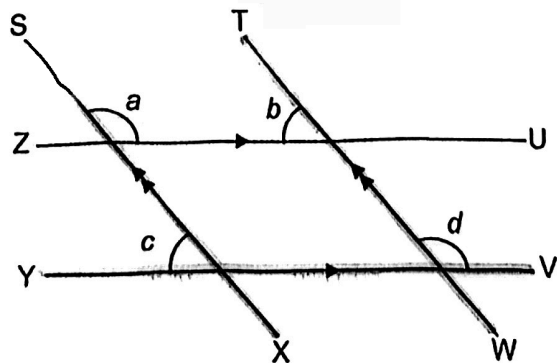

- (1)  $\angle a + \angle b$   
 (2)  $\angle a + \angle c$   
 (3)  $\angle b + \angle c$   
 (4)  $\angle b + \angle d$

8 Which of the following shows  $\frac{1}{4}$  of the figure shaded?

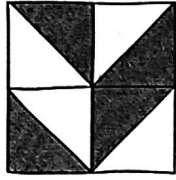

(1)

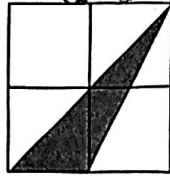

(2)

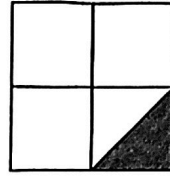

(3)

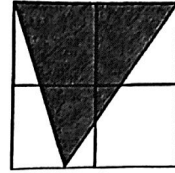

(4)



9 Find the area of triangle ABC.

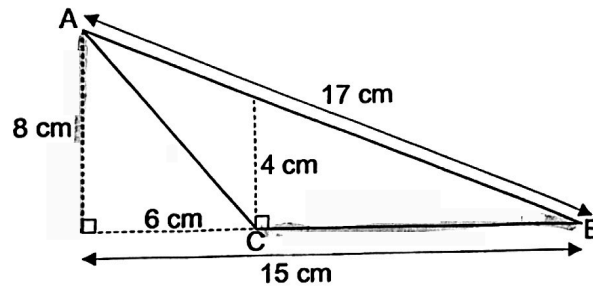

- (1)  $60 \text{ cm}^2$
- (2)  $36 \text{ cm}^2$
- (3)  $34 \text{ cm}^2$
- (4)  $30 \text{ cm}^2$

Use the information below to answer Questions 10 and 11.

The bar graph shows the number of muffins sold over 5 days. 60 muffins were sold on Thursday.

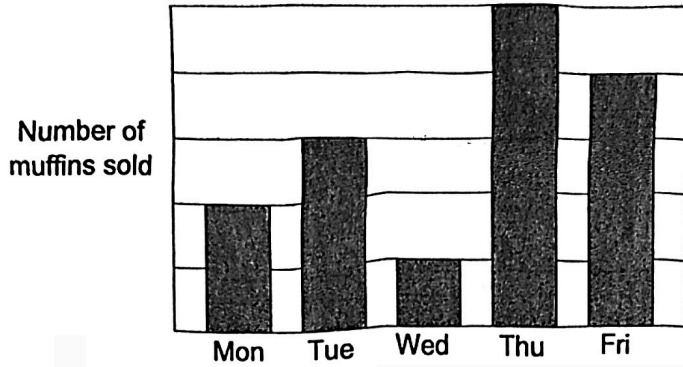

- 10 What was the total number of muffins sold from Monday to Wednesday?
- (1) 12
  - (2) 36
  - (3) 72
  - (4) 108
- 11 The ratio of the number of muffins sold on Friday to the number of muffins sold on Saturday was 4 : 5. How many muffins were sold over the 6 days?
- (1) 60
  - (2) 72
  - (3) 108
  - (4) 240

12 At a clearance sale, all items are sold at 40% discount. A customer gets 50% discount when he pays by cash. What is the percentage increase in the discount given when a customer pays by cash?

- (1) 10%
- (2) 20%
- (3) 25%
- (4) 50%

13 The clock shows 6 o'clock.

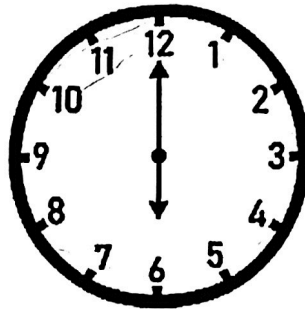

At what time will the two hands of the clock form an angle of  $150^\circ$ ?

- (1) 7 o'clock
- (2) 10 o'clock
- (3) 3 o'clock
- (4) 4 o'clock

- 14 ABC and CDE are right-angled triangles and GHFC is a square.  $\angle DCG = 41^\circ$  and  $\angle BCF = 27^\circ$ . Find  $\angle ACE$ .

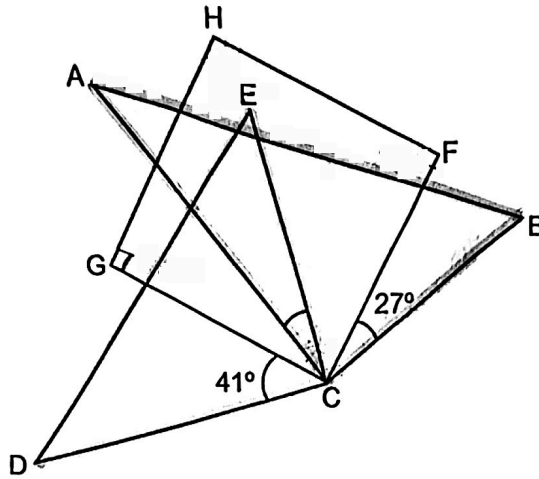

- (1)  $22^\circ$   
 (2)  $18^\circ$   
 (3)  $14^\circ$   
 (4)  $4^\circ$

- 15 A pattern is formed using the letters A and H.  
 The first 20 letters are shown.

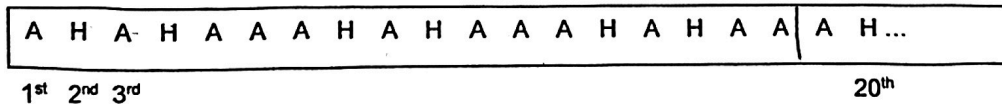

How many times does the letter A appear in the first 80 letters of the pattern?

- (1) 50  
 (2) 52  
 (3) 53  
 (4) 57







HENRY PARK PRIMARY SCHOOL  
2025 PRELIMINARY EXAMINATION  
MATHEMATICS  
PRIMARY 6

PAPER 1  
(BOOKLET B)

Name: \_\_\_\_\_ ( )

Class: Primary 6 \_\_\_\_\_

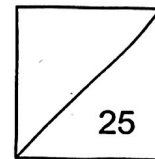

Total Time for Booklets A and B: 1 hour

Do not turn over this page until you are told to do so.

Follow all instructions carefully.

Answer all questions.

Write your answers in this booklet.

You are **not** allowed to use a calculator.

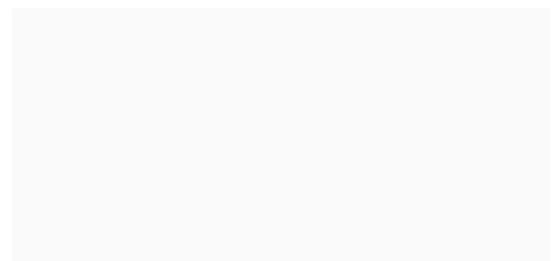

Questions 16 to 20 carry 1 mark each. Write your answers in the spaces provided.  
For questions which require units, give your answers in the units stated.

(5 marks)

---

16 Express  $5\frac{3}{20}$  as a decimal.

Ans: \_\_\_\_\_

---

17 Find the value of  $12.3 - 8.76$

Ans: \_\_\_\_\_

---

18 Express 1.2% as a fraction.

Ans: \_\_\_\_\_

- 19 A rectangular container is partly filled with 1-cm cubes as shown.  
How many more 1-cm cubes are needed to fill the container completely?

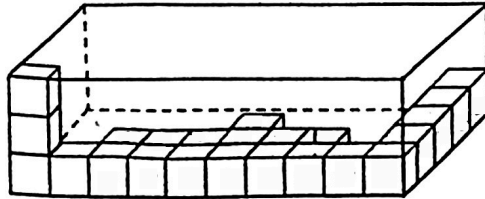

Ans: \_\_\_\_\_

- 20 The square grid shows the plan of a garden where 5 types of trees A, B, C, D and E are planted.

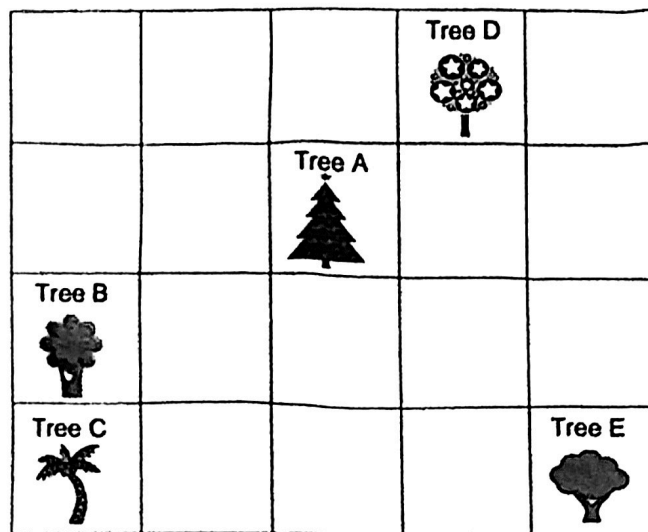

Tree A is north-east of one of the trees. Which tree is it?

Ans: Tree \_\_\_\_\_

Questions 21 to 30 carry 2 marks each. Show your working clearly and write your answers in the spaces provided. For questions which require units, give your answers in the units stated.

(20 marks)

21 The diagram shows a solid.

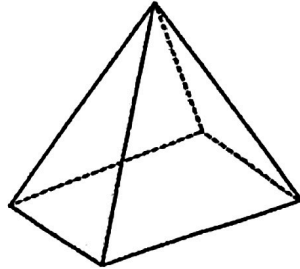

(a) Name the solid.

Ans: (a) \_\_\_\_\_

(b) How many faces does the solid have?

Ans: (b) \_\_\_\_\_

22 The figure is formed using 2 identical semicircles, each of radius 5 cm. Find the perimeter of the figure. Give your answer in terms of  $\pi$ .

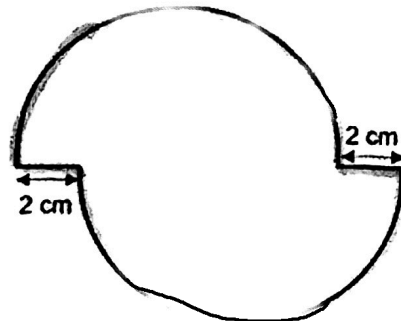

Ans: \_\_\_\_\_ cm

23 Sue is  $m$  years old. Ted is 3 times as old as Sue. Uma is 2 years younger than Ted.

(a) What is the total age of the three people in terms of  $m$ ?

Ans: (a) \_\_\_\_\_ years

(b) If  $m = 5$ , what is the total age of the three people?

Ans: (b) \_\_\_\_\_ a \_\_\_\_\_ years

---

24 A group of 10 adults and 11 children went to FunWorld Amusement Park. What was the least amount of money the group could have paid?

**FunWorld Amusement Park**

Child ticket price: \$12.10  
Adult ticket price: \$22.50

**Promotion**  
For every 3 paying adults, 2 children enter free!



Ans: \$ \_\_\_\_\_

- 25 PQRS is a straight line. The lengths of PS and PR are in the ratio 3 : 2 and the lengths of PR and QS are in ratio 6 : 5. What is the ratio of length PQ to length RS?

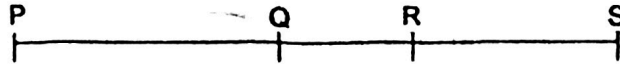

Ans: \_\_\_\_\_

- 26 ABCD is a rhombus. BAE and ADF are straight lines.

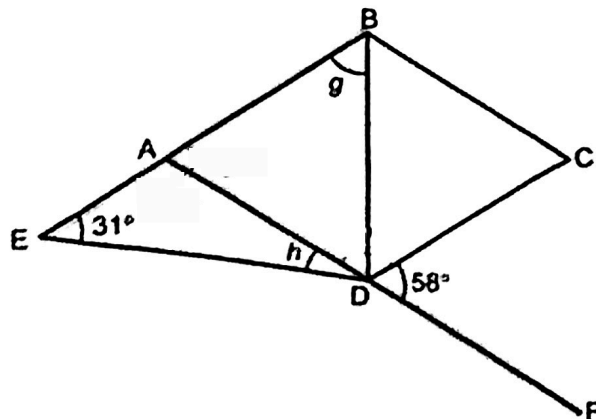

- (a) Find  $\angle g$ .

Ans: (a) \_\_\_\_\_°

- (b) Find  $\angle h$ .

Ans: (b) \_\_\_\_\_°

- 27 A plot of land is divided into seven identical rectangular fields. The length of each field is 20 m. Find the perimeter of the plot of land.

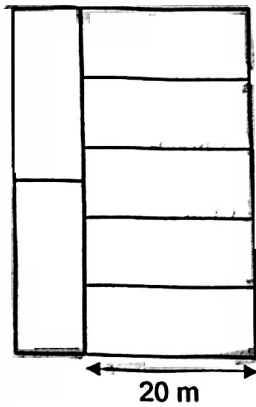

Ans: \_\_\_\_\_ m

---

- 28 A machine started labelling containers at 9 a.m. at the rate of 600 containers per hour. For every 3 hours, the machine stops for 15 minutes. How many containers can it label by 1.45 p.m. on the same day?

Ans: \_\_\_\_\_

---

29. Students were asked to choose one of the following items; a pouch, a keychain or a badge.  $\frac{1}{5}$  of them chose keychain. The number of students who chose pouch was  $\frac{1}{2}$  of those who chose badge.

- (a) The pie chart represents the number of students who chose each item. Label the pie chart by writing **P** for pouch, **K** for keychain and **B** for badge in the boxes.

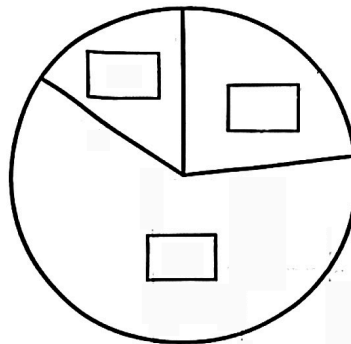

- (b) What fraction of the students chose badge?

Ans: (b) \_\_\_\_\_

---



- 30 7 similar cubes were stacked to make a solid figure such that it has the following front and side views.

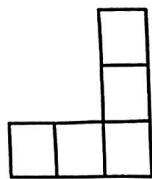

Front View

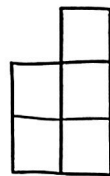

Side View

Draw the top view of the figure on the grid.

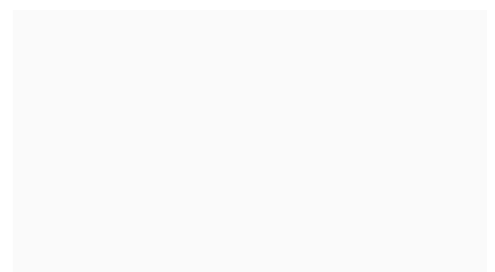





**HENRY PARK PRIMARY SCHOOL  
2025 PRELIMINARY EXAMINATION  
MATHEMATICS  
PRIMARY 6**

**PAPER 2**

Parent's Signature

\_\_\_\_\_

Name: \_\_\_\_\_ ( )

Class: Primary 6 \_\_\_\_\_

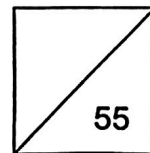

Time for Paper 2: 1 hour 30 minutes

Do not turn over this page until you are told to do so.

Follow all instructions carefully.

Answer all questions.

Show your working clearly as marks are awarded for correct working.

Write your answers in this booklet.

You are allowed to use a calculator.

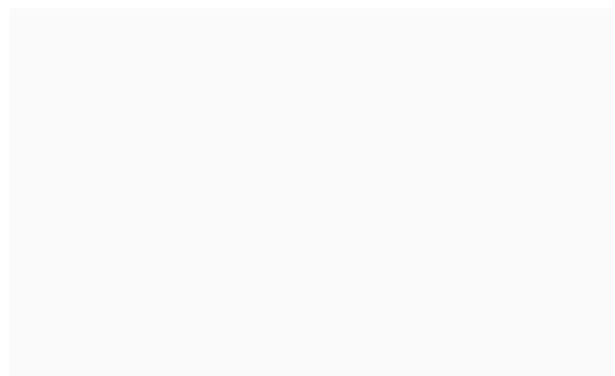

Questions 1 to 5 carry 2 marks each. Show your working clearly and write your answers in the spaces provided. For questions which require units, give your answers in the units stated.

(10 marks)

- 1 (a) How many factors are there in 36?

Ans: (a) \_\_\_\_\_

- (b) Write down the first common multiple of 4 and 10.

Ans: (b) \_\_\_\_\_

- 2 The table shows the time taken by 4 swimmers to complete a race. The time taken by Bala to complete the race is not shown.

Swimmer	Time in seconds (s)
Afiq	50.78
Bala	?
Cayden	48.12
Dai Ming	46.9

The average time taken by the 4 swimmers was 48.7s. What was the time taken by Bala to complete the race?

Ans: \_\_\_\_\_ s

Please do not write in the margin.

Please do not write in the margin.

Please do not write in the margin.

- 3 The figure is made up of a square and a  $\frac{3}{4}$ -circle. The  $\frac{3}{4}$ -circle with centre O has a diameter of 8 cm. What is the area of the figure? (Take  $\pi = 3.14$ )

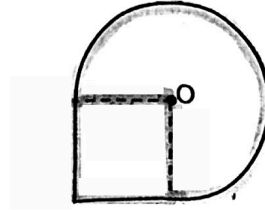

Ans: \_\_\_\_\_ cm<sup>2</sup>

- 4 Jack wanted to create a figure using white squares and grey squares, with PQ as the line of symmetry. He still had more squares to add.

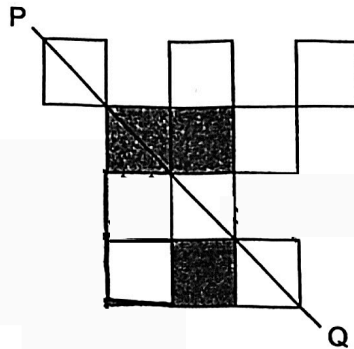

- (a) Measure and write down the length of PQ.

Ans: (a) \_\_\_\_\_ cm

- (b) What are the smallest numbers of white squares and grey squares Jack needs to add to the figure so that PQ remains as the line symmetry?

Ans: (b) white squares: \_\_\_\_\_

grey squares: \_\_\_\_\_

Please do not write in the margin.

- 5  $\triangle ABC$  and  $\triangle FEH$  are triangles and  $CFGD$  is a trapezium.  $BCD$ ,  $EFG$  and  $ACFH$  are straight lines.

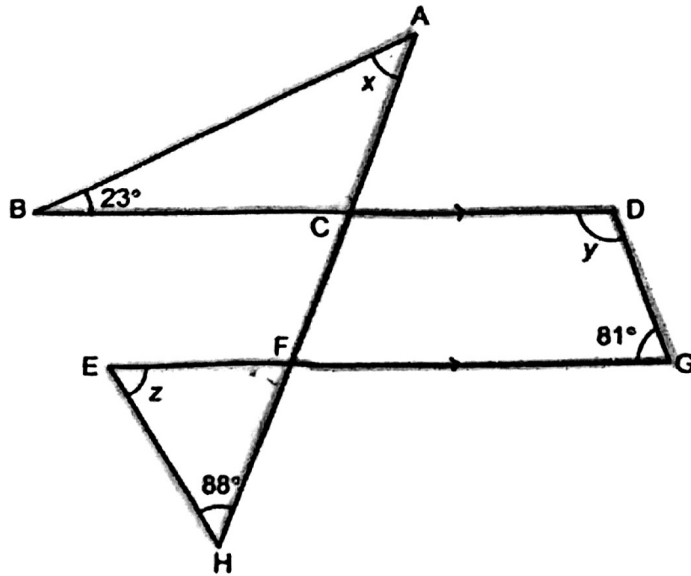

Find the sum of  $\angle x$ ,  $\angle y$  and  $\angle z$ .

Please do not write in the margin.

Please do not write in the margin.

Ans: \_\_\_\_\_°

Please do not write in the margin.

For questions 6 to 17, show your working clearly and write your answers in the spaces provided. The number of marks available is shown in the brackets [ ] at the end of each question or part-question.

(45 marks)

- 6 The table shows the number of boys and girls, and teachers in Schools A and B. Some of the information is missing.

	Boys	Girls	Teachers	Total
School A	845			
School B			154	
Total		2460	251	4642

- (a) What is the total number of boys in both schools?

[Blank space for answer]

Ans: (a) \_\_\_\_\_ [1]

- (b) The number of girls in School A is  $\frac{2}{3}$  of the number of girls in School B. Find the total number of students in School A.

[Blank space for answer]

Ans: (b) \_\_\_\_\_ [2]

Please do not write in the margin.

Please do not write in the margin.

Please do not write in the margin.

- 7 For every mobile phone that Susan sells, she earns a sum of money as shown.

10% of the first \$160 of the selling price  
and  
12% of the remaining selling price

Susan sold a mobile phone and earned \$76.90. What was the selling price of the mobile phone?



Please do not write in the margin

Please do not write in the margin.

Ans: \_\_\_\_\_ [3]

---

Please do not write in the margin.

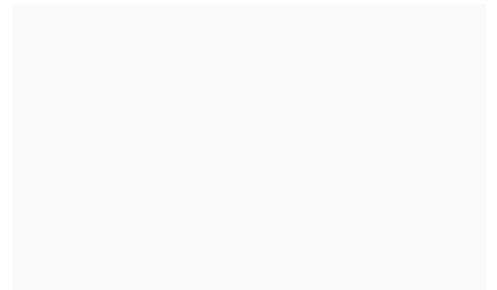



- 8 At 9 a.m., a truck left Town S for Town M at an average speed of 48 km/h. 30 minutes later, a car left Town M for Town S. The average speed of the car was twice the average speed of the truck. The truck and the car passed each other at 11.30 a.m. What is the distance between Town S and Town M?

Ans: \_\_\_\_\_ [3]

- 9 At a shop, erasers were sold in packets of 3 and pens were sold in packets of 5. Bella paid with a \$50-note for 9 erasers and 20 pens. How much change did Bella receive? Give your answer in terms of  $q$ .

	Cost per packet
Erasers	$\$q$
Pens	$\$2q$

Ans: \_\_\_\_\_ [3]

Please do not write in the margin.

Please do not write in the margin.

Please do not write in the margin.

10. Julie's coin box contained 20-cent and 50-cent coins. In the coin box, there were 7 more 50-cent coins than 20-cent coins. The total amount of money in the coin box was \$18.90.

(a) How many coins were in the coin box?

Ans: (a) \_\_\_\_\_ [3]

(b) How much money does Julie have left in the coin box after spending all her 20-cent coins on food?

Ans: (b) \_\_\_\_\_ [1]

---

**Please do not write in the margin.**

- 11 Adam cut a rope into 3 pieces. The first piece was 4.5 m longer than  $\frac{1}{4}$  the original length of the rope. The second piece was 3.3 m longer than  $\frac{3}{5}$  of the remaining rope after the first cut. The third piece was 8.7 m. What was the original length of the rope?

Ans: \_\_\_\_\_ [4]

---

**Please do not write in the margin.**

12

Mrs Brown bought  $\frac{2}{5}$  as many cupcakes as pies for a party. She spent  $\frac{3}{4}$  as much on each cupcake as each pie. Each cupcake cost \$4.50. She paid \$504 more on the pies than the cupcakes.

(a) How much did she pay for each pie?

Ans: (a) \_\_\_\_\_ [1]

(b) How many pies did she buy?

Ans: (b) \_\_\_\_\_ [4]

---

Please do not write in the margin.

- 13 There were some apples and oranges in a box. In the morning, when 24 apples were added to the box, the ratio of the number of apples to the number of oranges in the box was 6 : 5. Then 35 oranges were removed from the box and the ratio became 4 : 1

(a) How many apples were there in the box at first?

Ans: (a) \_\_\_\_\_ [3]

- (b) In the afternoon, more apples and oranges were added into the box. The number of apples increased by 65% and the number of oranges increased by 120%. Find the total number of apples and oranges added to the box in the afternoon.

Ans: (b) \_\_\_\_\_ [2]

---

**Please do not write in the margin.**

14

The figure shows taps A and B, a rectangular tank X and a cubical tank Y. Both tanks were empty.

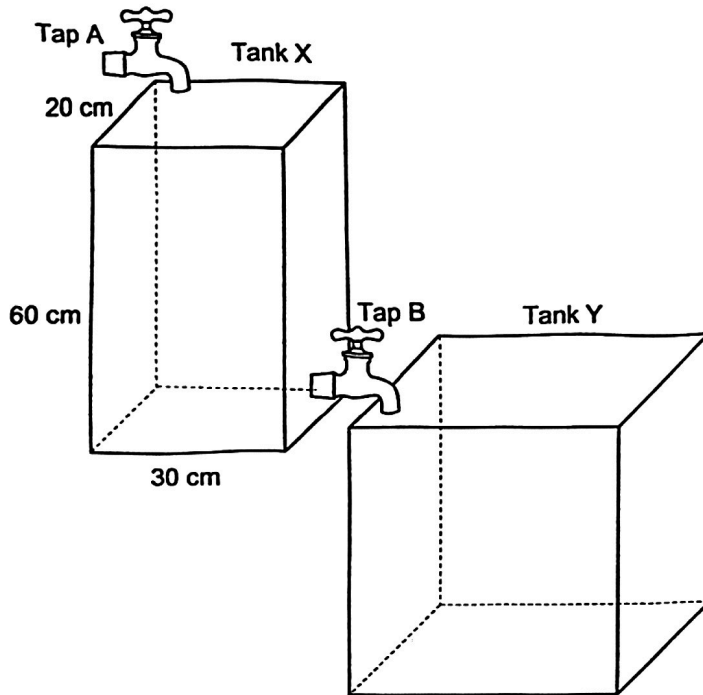

At 08 20, tap A was turned on. Water flowed into the tank from tap A at a rate of 4.8 litres per minute. After 5 minutes, tap B was turned on.

At 08 35, both taps were turned off. Tank X was half-filled with water and Tank Y was 25% filled with water.

Find the length of tank Y.

Ans: \_\_\_\_\_ [3]

---

Please do not write in the margin.

15. A florist sold roses from Monday to Sunday. The line graph shows the number of roses left unsold at the end of each day.

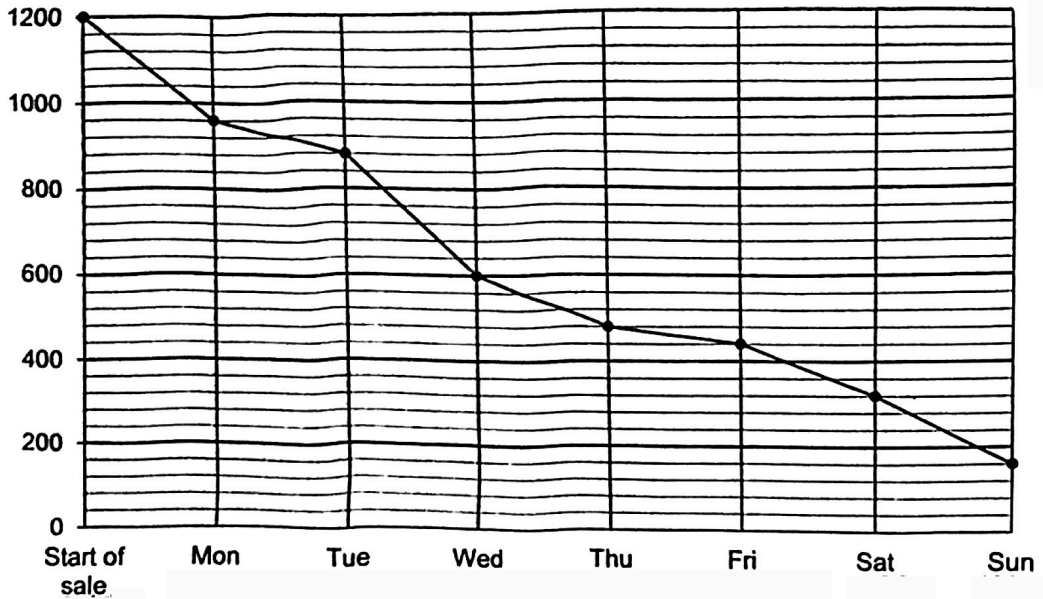

Please do not write in the margin.

Please do not write in the margin.

- (a) On which day had the florist sold half the total number of roses for the week?

Ans: (a) \_\_\_\_\_ [1]

- (b) On which two days did the florist sell the same number of roses?

Ans: (b) \_\_\_\_\_ and \_\_\_\_\_ [1]

- (c) The usual price of a stalk of rose was \$9. On Saturday, after selling 52 stalks of roses, the remaining roses were sold at a discount of 25%. What was the total amount collected on Saturday?

Ans: (c) \_\_\_\_\_ [2]

Please do not write in the margin.

16 A trapezium ABCD is drawn in a square grid.

- (a) Using the line DW, draw an isosceles triangle DWX such that  $\angle DWX$  is less than  $90^\circ$  and  $DW = WX$ . [1]
- (b) Using point E, draw a parallelogram EFGH such that it has the same perimeter as ABCD. Point H is south-east of E while point F is east of E. [2]

Use a pencil to draw your diagram and label it clearly.

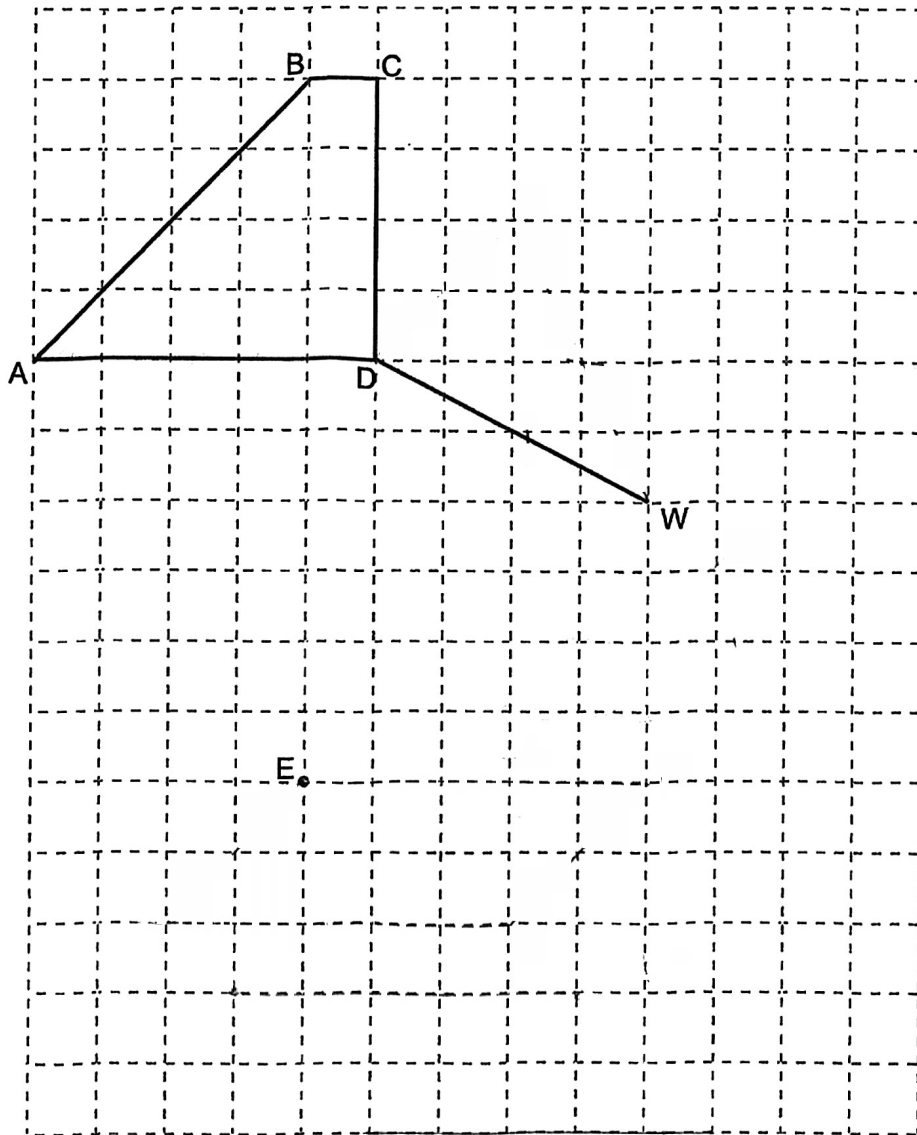

Please do not write in the margin.

Please do not write in the margin.

Please do not write in the margin.



- 16 (c) LMNO is a square and ONP is an isosceles triangle where  $ON = OP$ .  
Given that  $\angle LNP = 103^\circ$ , find  $\angle OPL$ .

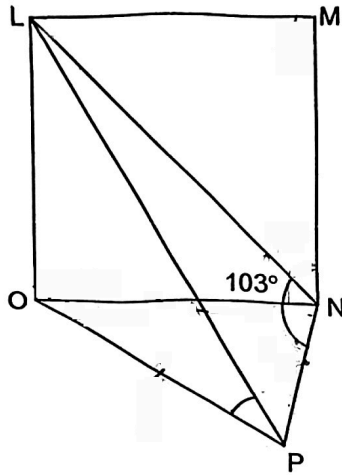

Please do not write in the margin.

Please do not write in the margin.

Ans:(c) \_\_\_\_\_ [2]

Please do not write in the margin.

17. The first four figures of a pattern are shown below.

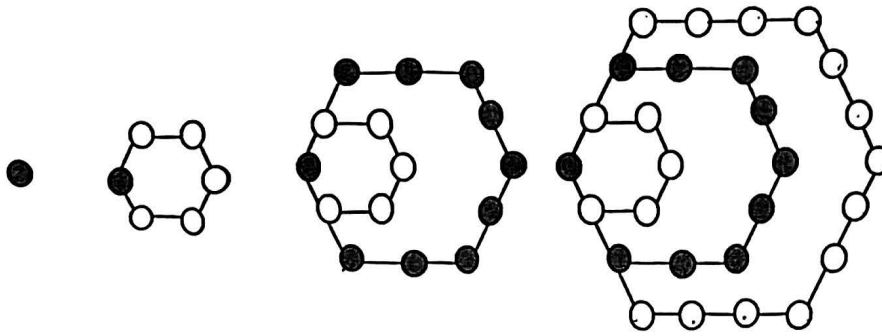

Figure 1    Figure 2

Figure 3

Figure 4

The table shows the number of white and grey circles used for the first four figures.

Figure Number	1	2	3	4	5
Number of white circles	0	5	5	18	18
Number of grey circles	1	1	10	10	

[1]

- (a) Fill in the table for Figure 5.
- (b) How many white and grey circles are there altogether in Figure 28?

Ans: (b) \_\_\_\_\_ [2]

---

Please do not write in the margin.

End of Paper 2

Page 15

SCHOOL : HENRY PARK PRIMARY SCHOOL  
 LEVEL : PRIMARY 6  
 SUBJECT : MATH  
 TERM : 2025 PRELIM EXAM

BOOKLET A

Q1	Q2	Q3	Q4	Q5	Q6	Q7	Q8	Q9	Q10
2	2	3	1	3	4	3	2	2	3
Q11	Q12	Q13	Q14	Q15					
4	3	1	1	3					

BOOKLET B

Q16	$5\frac{3}{20} = 5\frac{15}{100} = 5.15$	ANS : 5.15
Q17	$12.3 - 8.76 = 3.54$	ANS : 3.54
Q18	$1.2\% = \frac{1.2}{100} = \frac{12}{1000} = \frac{3}{250}$	ANS : $\frac{3}{250}$
Q19	$10 \times 5 \times 3 = 150$ . $150 - 23 = 127$ .	ANS : 127
Q20	Tree A is north-east of Tree <u>C</u> .	ANS : Tree C
Q21	(a) It is a pyramid. (b) It has 5 faces	ANS : (a) Pyramid (b) 5 faces
Q22	Perimeter of the figure $= 2 \times 5 \times \pi + 4 = (10\pi + 4)$ cm	ANS : $(10\pi + 4)$ cm
Q23	(a) Total age = $m + 3m + (3m - 2) = 7m - 2$ (b) $m = 5$ , Total age = $7(5) - 2 = 35 - 2 = 33$ .	ANS : (a) $(7m - 2)$ years (b) 33 years

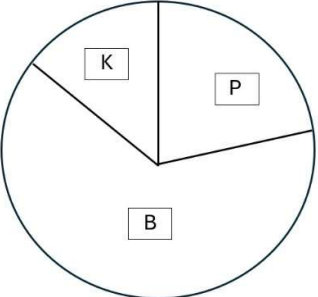
Q24	$10 \div 3 = 3R1, 3 \times 2 = 6, 11 - 6 = 5,$ Least amount of money = $10 \times \$22.50 + 5 \times \$12.10 = \$297.60$ ANS : \$285.50
Q25	P ----- Q ----- R ----- S PS : PR = 3 : 2 = 9 : 6 and PR : QS = 6 : 5. Thus, if PS = 9u, then PR = 6u, QS = 5u, → QR = PR + QS – PS = 6u + 5u – 9u = 2u, PQ = PR – QR = 6u – 2u = 4u, RS = QS – QR = 5u – 2u = 3u, ∴ PQ : RS = 4u : 3u = 4 : 3. ANS : 4 : 3
Q26	(a) $\angle g = (180^\circ - 58^\circ) \div 2 = 61^\circ$ ANS : (a) $61^\circ$ (b) $\angle BAD = \angle CDF = 58^\circ, \angle h = 58^\circ - 31^\circ = 27^\circ$ (b) $27^\circ$
Q27	Width of 1 rectangular field = $20 \times 2 \div 5 = 8$ m. Perimeter of the plot of land = $2 \times (40 + 8 + 20) = 136$ m. ANS : 136 m
Q28	Time lapses from 9 a.m. to 1.45 p.m. is 4 h 45 min. 4 h 45 min = 3 h + 15 min + 1 h 30 min. 3 h + 1 h 30 min = 4 h 30 min = 4.5 h. ∴ $600 \times 4.5 = 2700$ containers. ANS : 2700
Q29	(a) ANS : (a) See figure  (b) $1 - \frac{1}{5} = \frac{4}{5}$ , fraction of badge = $\frac{4}{5} \times \frac{2}{3} = \frac{8}{15}$ . ANS : (b) $\frac{8}{15}$

Q30		ANS : See figure
-----	--	------------------

## PAPER 2

Q1	<p>(a) <math>36 = 1 \times 36 = 2 \times 18 = 3 \times 12 = 4 \times 9 = 6 \times 6</math>.  <math>\therefore 36</math> has 9 factors <span style="float: right;">ANS : 9</span></p> <p>(b) Multiples of 4 : 4, 8, 12, 16, <b>20</b>, 24, 28, 32, .....          Multiples of 10 : 10, <b>20</b>, 30, 40, .....          First common multiple of 4 and 10 = 20. ANS : 20</p>
Q2	<p>Total time taken = <math>4 \times 48.7 = 194.8</math>,          Time taken by Bala = <math>194.8 - (50.78 + 48.12 + 46.9)</math>  <math>= 49</math> <span style="float: right;">ANS : 49 seconds</span></p>
Q3	<p>Area of figure = <math>4 \times 4 + \frac{3}{4} \times 3.14 \times 4 \times 4 = 53.68 \text{ cm}^2</math>.  <span style="float: right;">ANS : <math>53.68 \text{ cm}^2</math></span></p>
Q4	<p>(a) Length PQ = 6.4 cm</p> <div style="display: flex; align-items: center; justify-content: center;"> <div style="margin-left: 20px;"> <p>Ans : (a) 6.4 cm</p> <p>Ans : (b) white squares : 3              Grey squares : 2</p> </div> </div>
Q5	<p><math>\angle y = 180^\circ - 81^\circ = 99^\circ</math>.  <math>\angle BCH = \angle EFH = \angle x + 23^\circ</math>,  <math>\angle x + 23^\circ + \angle z + 88^\circ = 180^\circ</math>,  <math>\angle x + \angle z = 180^\circ - 23^\circ - 88^\circ = 69</math>,  <math>\therefore \angle x + \angle y + \angle z = 99^\circ + 69^\circ = 168^\circ</math>. <span style="float: right;">ANS : <math>168^\circ</math></span></p>

Q6	<p>(a) Total number of boys = <math>4642 - 251 - 2460 = 1931</math>.</p> <p>(b) Number of girls on School A = <math>2460 \times \frac{2}{2+3} = 984</math>.</p> <p>Total number of students in School A = <math>845 + 984 = 1829</math>.</p> <p>ANS : (a) 1,931 (b) 1,829</p>
Q7	<p><math>\\$160 \times 10\% = \\$16</math>, <math>\\$76.90 - \\$16 = \\$60.90</math>,</p> <p><math>\\$60.90 \div 12\% = \\$507.50</math>, <math>\\$507.50 + \\$160 = \\$667.50</math></p> <p>ANS : \$667.50</p>
Q8	<p>Distance travelled by the truck = <math>48 \times 2.5 = 120</math> km.</p> <p>Distance travelled by the car = <math>(2 \times 48) \times 2.0 = 192</math> km.</p> <p>Distance between Town S and Town M = <math>120 + 192 = 312</math> km.</p> <p>ANS : 312 km</p>
Q9	<p>Cost of 9 erasers = <math>\frac{9}{3} \times \\$q = \\$3q</math>,</p> <p>Cost of 20 pens = <math>\frac{20}{5} \times \\$2q = \\$8q</math>,</p> <p>Change received = <math>\\$50 - \\$3q - \\$8q = \\$(50 - 11q)</math></p> <p>ANS : (a) <math>\\$(50 - 11q)</math></p>
Q10	<p>(a) 7 more 50¢ coins <math>\rightarrow 7 \times \\$0.50 = \\$3.50</math>,</p> <p><math>\\$18.90 - \\$3.50 = \\$15.40</math>, <math>\\$0.50 + \\$0.20 = \\$0.70</math>.</p> <p>Number of pairs of 20¢ and 50¢ = <math>\\$15.40 \div \\$0.70 = 22</math>.</p> <p>Total number of coins = <math>2 \times 22 + 7 = 44 + 7 = 51</math>.</p> <p>(b) Amount of money left = <math>29 \times \\$0.50 = \\$14.50</math></p> <p>ANS : (a) 51 (b) \$14.50</p>
Q11	<p>Working backwards,</p> <p><math>\frac{2}{5}</math> of the remaining length of rope – 3.3 m = 8.7 m.</p> <p>Remaining length of rope = <math>(8.7 + 3.3) \times \frac{5}{2} = 30</math> m.</p> <p><math>\therefore \frac{3}{4}</math> of original length of rope – 4.5 m = 30 m.</p> <p>Original length of rope = <math>(30 + 4.5) \times \frac{4}{3} = 46</math> m</p> <p>ANS : 46 m</p>

Q12	<p>(a) Cost of each pie = <math>\\$4.50 \div \frac{3}{4} = \\$4.50 \times \frac{4}{3} = \\$6</math>.</p> <p>(b) For each group of 2 cupcakes and 5 pies, the cost of pies is more than that of the cupcakes  <math>= 5 \times \\$6 - 2 \times \\$4.50 = \\$30 - \\$9 = \\$21</math>.  Number of group purchased = <math>\\$504 \div \\$21 = 24</math>.  Number of pies purchased = <math>5 \times 24 = 120</math>.</p> <p style="text-align: right;">ANS : (a) \$6 (b) 120</p>									
Q13	<p>(a) The number of apples in the end was the same before and after the 35 oranges were removed.  Common multiple of 6 and 4 is LCM(6, 4) = 12.</p> <table style="margin-left: auto; margin-right: auto;"> <thead> <tr> <th></th> <th style="text-align: center;"><u>Apples</u></th> <th style="text-align: center;"><u>Oranges</u></th> </tr> </thead> <tbody> <tr> <td>Before</td> <td style="text-align: center;">12u</td> <td style="text-align: center;">10u</td> </tr> <tr> <td>After</td> <td style="text-align: center;">12u</td> <td style="text-align: center;">3u</td> </tr> </tbody> </table> <p><math>10u - 3u = 7u = 35 \rightarrow u = 35 \div 7 = 5</math>. <math>12u = 12 \times 5 = 60</math>.  <math>\therefore</math> Number of apples at first = <math>60 - 24 = 36</math>.</p> <p>(b) In the afternoon,  Number of apples added = <math>60 \times 65\% = 39</math>.  Number of oranges added = <math>3 \times 5 \times 120\% = 18</math>.  Total number of apples and oranges added = <math>39 + 18 = 57</math>.</p> <p style="text-align: right;">ANS : (a) 36 (b) 57</p>		<u>Apples</u>	<u>Oranges</u>	Before	12u	10u	After	12u	3u
	<u>Apples</u>	<u>Oranges</u>								
Before	12u	10u								
After	12u	3u								
Q14	<p>Volume of water flowed from Tap A  <math>= 4.8 \times 15 = 72 \text{ l} = 72000 \text{ ml} = 72000 \text{ cm}^3</math>.</p> <p>Volume of water remained in Tank X  <math>= 30 \times 20 \times 60 \times \frac{1}{2} = 18000 \text{ cm}^3</math>.</p> <p>Volume of water flowed into Tank Y  <math>= 72000 - 18000 = 54000 \text{ cm}^3</math>.</p> <p>Capacity of Tank Y = <math>54000 \div 25\% = 216000 \text{ cm}^3</math>.  Length of Tank Y = <math>\sqrt[3]{216000} = 60 \text{ cm}</math>.</p> <p style="text-align: right;">ANS : 60 cm</p>									

Q15

(a) Number of roses at the start of sales = 1200.  
Number of roses left after half of the roses were sold  
=  $1200 \div 2 = 600$ .  
From the graph, 600 roses were left unsold at the end of Wednesday.  
 $\therefore$  The florist had sold half of the roses on Wednesday.

(b) The number of roses sold on each day was,  

<u>Mon</u>	<u>Tue</u>	<u>Wed</u>	<u>Thu</u>	<u>Fri</u>	<u>Sat</u>	<u>Sun</u>
240	80	280	120	40	120	160

  
On Thursday and Saturday, 120 roses were sold.

(c)  $120 - 52 = 68$ ,  
Amount collected on Saturday =  $52 \times \$9 + 68 \times \$9 \times 75\%$   
=  $\$468 + \$459 = \$927$

ANS : (a) Wed  
(b) Thu and Sat  
(c) \$927

Q16

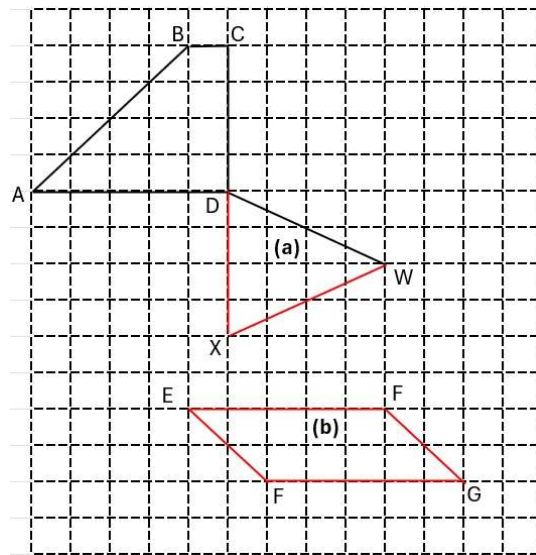

ANS : (a), (b) See figure



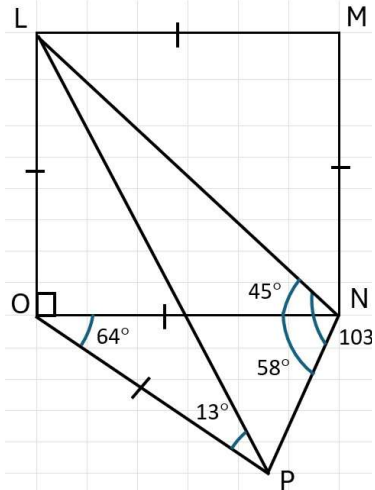

$$\begin{aligned} \angle LNO &= 45^\circ, \\ \angle ONP &= \angle LNP - \angle LNO \\ &= 103^\circ - 45^\circ = 58^\circ, \\ \angle OPN &= \angle ONP = 58^\circ, \\ \angle NOP &= 180^\circ - 2 \times 58^\circ = 64^\circ, \\ \angle LOP &= 90^\circ + 64^\circ = 154^\circ, \\ \angle OPL &= (180^\circ - 154^\circ) \div 2 = 13^\circ. \end{aligned}$$

ANS :  $13^\circ$

Q17

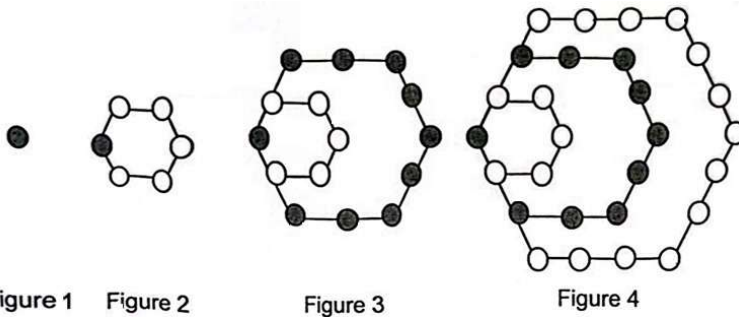

Figure 1    Figure 2    Figure 3    Figure 4

(a)

Figure Number	1	2	3	4	5
Number of white circles	0	5	5	18	18
Number of grey circles	1	1	10	10	<b>27</b>

Number of grey circles in Figure 5 =  $10 + (4 \times 4 + 1) = 27$ .

(b) Total number of white and grey circles in Figure 28

$$\begin{aligned} &= 1 + (4 \times 1 + 1) + (4 \times 2 + 1) + (4 \times 3 + 1) + \dots + (4 \times 27 + 1) \\ &= 4 \times (1 + 2 + 3 + \dots + 27) + 28 \quad 1540 \\ &= 4 \times \frac{1}{2} \times 27 \times 28 + 28 \\ &= 1512 + 28 \\ &= 1540 \end{aligned}$$

ANS : (a) 27  
(b) 1540

