

Name: ◆-----()

26 August 2025

Class: Primary 6 SYICIGISE / P

SINGAPORE CHINESE GIRLS' SCHOOL  
PRELIMINARY EXAMINATION 2025

PRIMARY 6  
SCIENCE  
BOOKLET A

Total Time for Booklets A and B: 1h 45 min

INSTRUCTIONS TO CANDIDATES

1. Write your index No. in the boxes at the top right-hand corner.
2. Do not turn over this page until you are told to do so.
3. Follow all instructions carefully.
4. Answer all questions.
5. Use a 2B pencil to shade your answers on the Optical Answer Sheet (OAS).

This booklet consists of 20 printed pages.



For each question from 1 to 28, four options are given. One of them is the correct answer. Make your choice (1, 2, 3 or 4) and shade your answer on the Optical Answer Sheet.

(56 marks)

1 Study the diagrams of a plant below.

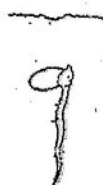

A



B

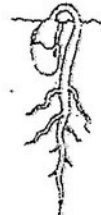

C

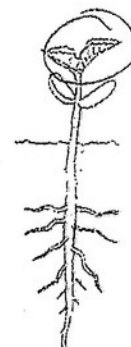

D

At which stage(s) does the plant take in sunlight to make food?

- (1) D only
- (2) C and D only
- (3) A and B only
- (4) A, B, C and D

2 The diagrams below show the reproductive parts found in a flowering plant and humans.

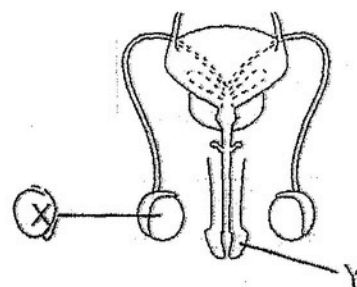
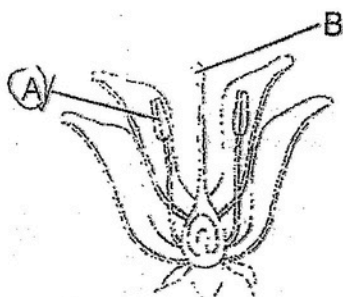

Which of the parts produce male reproductive cells?

- (1) A and X
- (2) A and Y
- (3) B and X
- (4) B and Y

- 3 John recorded the number of organisms he saw on a tree in the table below.

Organism	Number of organisms
ant	15
butterfly	9
fern	3
spider	5
caterpillar	10

Based on the table, which of the following statements is correct?

- (1) There are 5 communities living on the tree.
- (2) There are 3 populations of producers living on the tree.
- (3) There are 4 populations of organisms living on the tree.
- (4) There are 2 populations of consumers living on the tree.

- 4 Marsha built a small pond in her garden on Day 1.

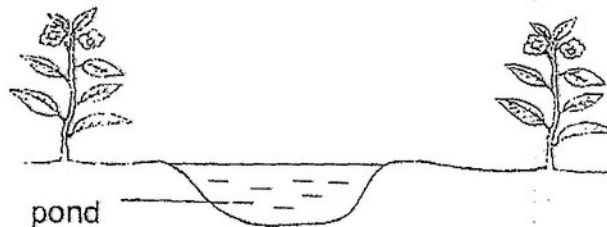

She observed three types of animals, mosquito, butterfly and frog, living in the garden. The number of days needed for their eggs to hatch is shown below.

Characteristic	Butterfly	Mosquito	Frog
Number of days needed for egg to hatch	4	2	21

On Day 6, what would Marsha most likely find in the pond?

- (1) frog eggs and caterpillars
- (2) mosquito larva and tadpoles
- (3) mosquito larva and frog eggs
- (4) caterpillars and mosquito larva

5 Study the table below.

Living thing	Does it make its own food?	Question K	Does it produce flowers?
grass	Yes	Yes	Yes
<b>J</b>	No	No	No
mango tree	Yes	Yes	Yes

Which of the following is correct?

	Living thing J	Question K
(1)	moss	Does it produce spores?
(2)	mushroom	Does it produce seeds?
(3)	rose plant	Are its seeds dispersed by animal?
(4)	bird's nest fern	Are its seeds dispersed by wind?

6 The diagrams below show flower J and the fruit it develops into.

brightly coloured petals

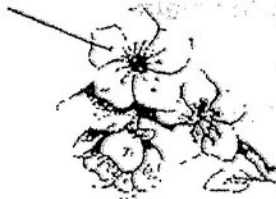

Flower J

hard seed

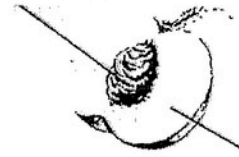

juicy and fleshy

Fruit of flower J

Which statement(s) is/are correct?

- A Flower J has only one ovule.
- B Seeds of fruit J are dispersed by splitting.
- C Flower J is most likely pollinated by animals.
- D The seed developed from the ovary of Flower J.

- (1) A and B
- (2) A and C
- (3) B and C
- (4) C and D

- 7 Limin placed the set-up below in a bright place.

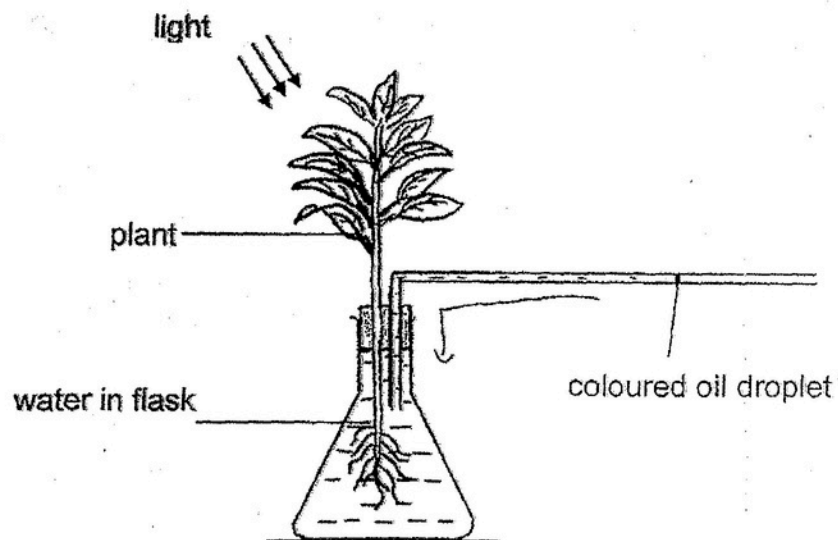

She observed that the coloured oil droplet moved towards the flask.

Which of the statements below explain(s) her observation?

- A Oxygen was taken in by the plant.
- B Carbon dioxide was given out by the plant.
- C Water was taken in by the plant.
- D Carbon dioxide was taken in by the plant.

Which of the above is correct?

- (1) C only
- (2) D only
- (3) A, B and C only
- (4) A, B, C and D

- 8 The table below shows the functions of the different organs in the human digestive system.

Function	Organs in the human digestive system			
	W	X	Y	Z
breaks down food	✓	✓		
absorbs digested food		✓		
absorbs excess water				✓

Which of the following correctly identifies organs W, X, Y and Z?

	W	X	Y	Z
(1)	gullet	mouth	large intestine	small intestine
(2)	mouth	small intestine	gullet	large intestine
(3)	mouth	large intestine	gullet	small intestine
(4)	gullet	small intestine	mouth	large intestine

- 9 Hui Leng wanted to find out how a certain variable will affect the growth of guppies in a fish tank. The following are variables that she either changed or kept the same.

- A Amount of food
- B Size of fish tank
- C Number of guppies
- D Temperature of water

Which of the following is a possible experiment Hui Leng can conduct to find out the effect of a certain variable on the growth of guppies?

	Aim of experiment	Variables kept constant
(1)	To find out if overcrowding affects the growth of guppies	A, B and C
(2)	To find out if temperature of water affects the growth of guppies	A, B and C
(3)	To find out if the size of the fish tank affects the growth of guppies	A, B and D
(4)	To find out if the amount of food given affects the growth of guppies	B and D

- 10 On a cool evening, Delia wore a face mask while she walked around a park. She did not remove her face mask or talk while walking. When she returned home, she noticed that the side of the mask in contact with her face was wet.

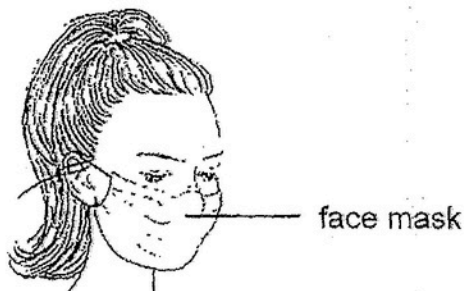

The statements below describe differences between exhaled air and inhaled air.

- A Exhaled air is warmer than inhaled air.
- B Exhaled air has less oxygen than inhaled air.
- C Exhaled air has more water vapour than inhaled air.

Which of the statement/s can be used to explain why the inner surface of the face mask was wet?

- (1) C only
- (2) A and B only
- (3) A and C only
- (4) A, B and C

- 11 The diagrams below show the circulatory systems of a man and a fish. The arrows represent blood vessels that carry blood to various organs in the body.

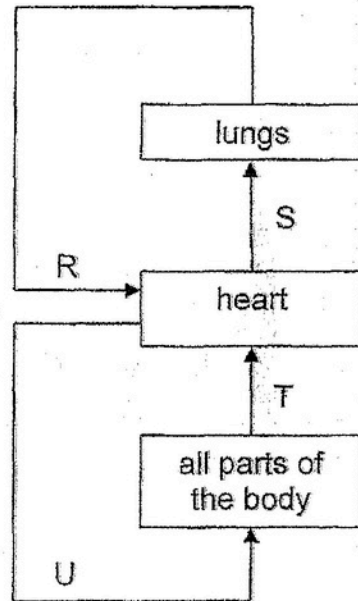

Man

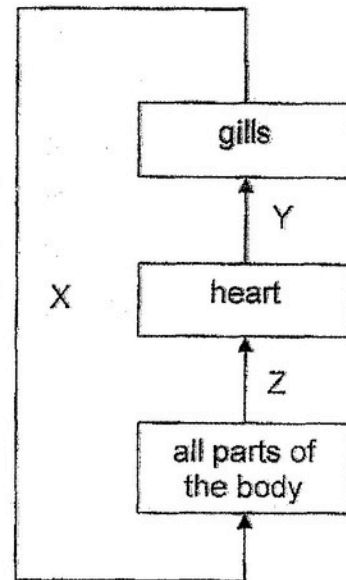

Fish

Which of the following is correct?

	Blood rich in oxygen	Blood rich in carbon dioxide
(1)	R, U, X	S, T, Y, Z
(2)	R, S, Y	T, U, X, Z
(3)	T, U, X, Z	R, S, Y
(4)	S, T, Y, Z	R, U, X

- 12 The graph shows the average air temperatures in a town throughout the year 2022.

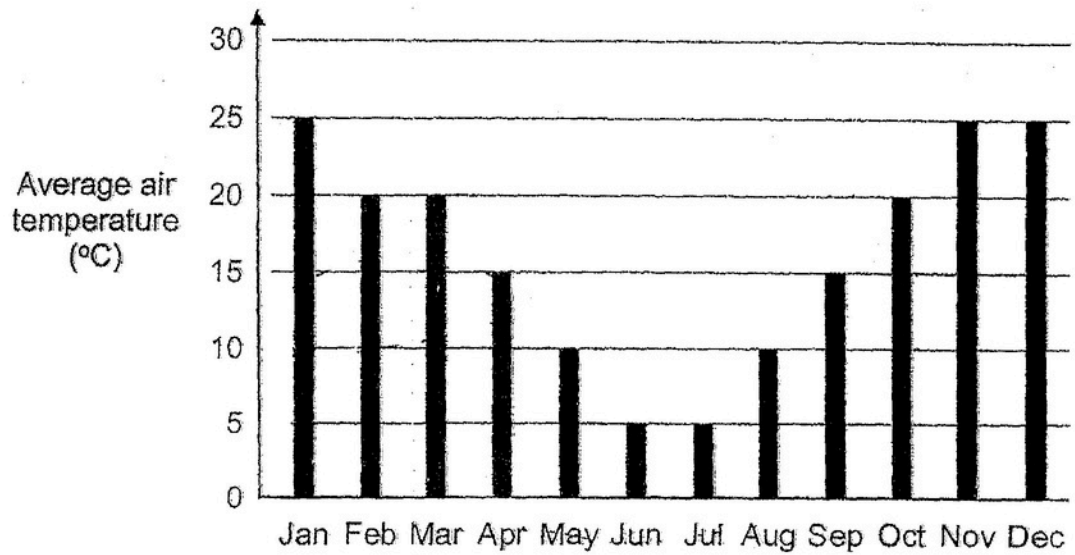

The table below shows information about the growth of four different plants.

	Plant			
	P	Q	R	S
<b>Air temperature suitable for its growth (°C)</b>	Below 11	At least 20	At least 15	Above 18
<b>Time taken to become adult plants (months)</b>	6	5	4	8

Based on the information above, which plants, P, Q, R or S can grow to become adult plants in the town?

- (1) P and R
- (2) Q and R
- (3) P and S
- (4) P, Q and R

- 13 The graph below shows how the number of fish in a pond community changed over a period of six months. The fish in the pond feed on the water plants.

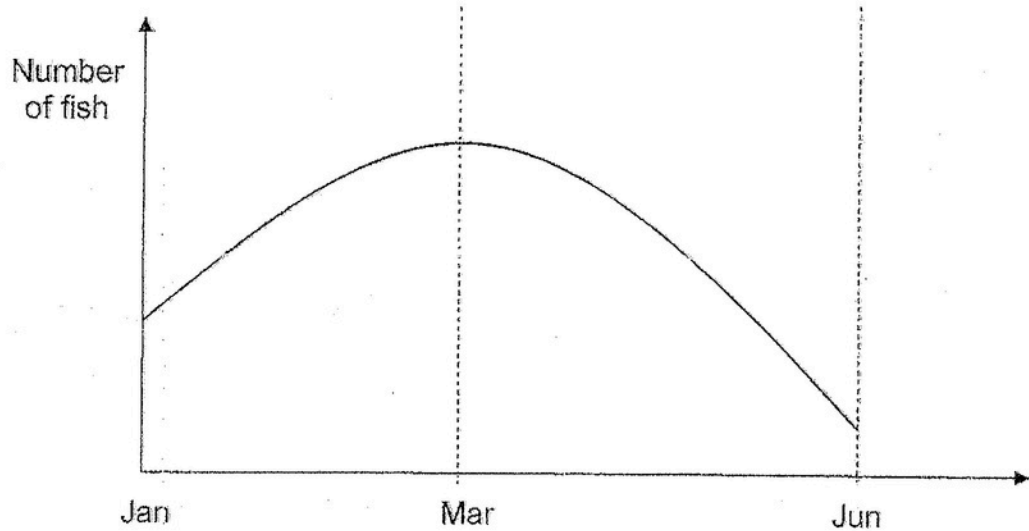

What are the possible reasons for the change in the number of fish in the pond?

- A From March to June, water plants were removed from the pond.
  - B From January to March, the birth rate of the fish was equal to its death rate.
  - C From January to March, the number of animals feeding on the fish increased.
  - D From March to June, several organism X were added and they competed for food with the fish.
- (1) A and C only  
(2) A and D only  
(3) B and C only  
(4) B and D only

- 14 Greenhouse gases may be produced when fuels are burnt for energy. The table shows some information about three types of fuels, F, G and H.

Fuel	Number of years fuel can last	Energy produced	Amount of greenhouse gases produced
F	50-60	low	high
G	50-60	medium	medium
H	50-60	high	low

Which of the following **cannot** be concluded based on the information above?

- (1) F is the least environmentally friendly fuel.
  - (2) Acid rain forms only from the burning of F and G.
  - (3) F, G and H are non-renewable sources of energy.
  - (4) Burning of F, G and H contributes to global warming.
- 15 A life jacket is used to prevent a person from drowning in water. The life jacket must be inflated with air as it is the air that prevents the person from sinking in water.

life jacket

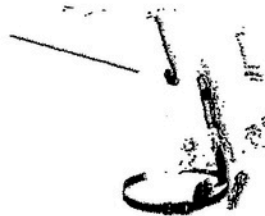

Material W was used to make a life jacket. The life jacket was inflated and placed in water. After some time, the life jacket sank and the inside was filled with water. There were no holes in the life jacket.

Material W did not allow the life jacket to stay afloat because it is not

- 
- (1) light
  - (2) strong
  - (3) flexible
  - (4) waterproof

- 16 The diagram below shows what happens to a ping pong ball after a force was applied to it, causing a change in its shape. There were no holes in the ping pong ball.

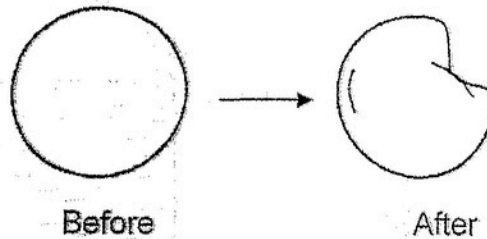

Which of the following is true about the mass and volume of air in the ping pong ball after the force was applied to it?

	Mass	Volume
(1)	remains the same	remains the same
(2)	decreases	decreases
(3)	increases	increases
(4)	remains the same	decreases

- 17 The diagram below shows the water cycle.

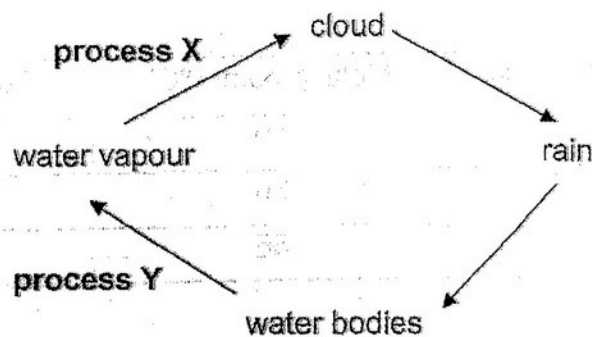

Based on the diagram above, which of the following statements is correct?

- (1) Heat is lost by water in process Y.
- (2) Heat is gained by water in process X.
- (3) Process Y does not take place at a fixed temperature.
- (4) There is a change in state in process Y but not in process X.

- 18 Gary poured water at different temperatures into three identical cups P, Q and R. After five minutes, water droplets formed on the surfaces of cups P, Q and R, as shown below.

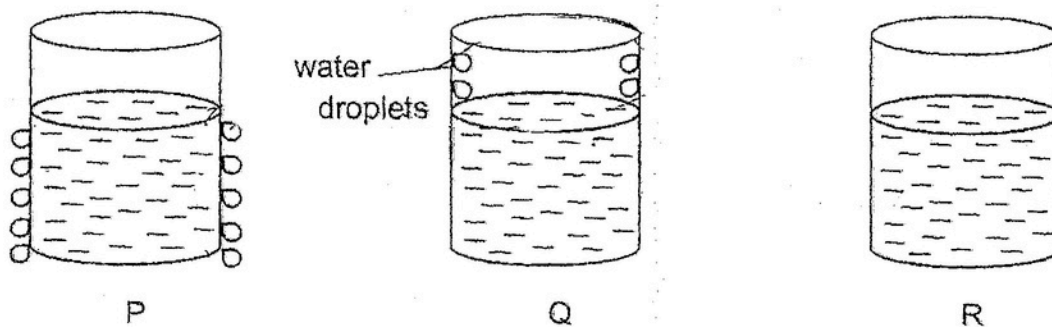

Which of the following shows the temperature of the water in the cups from the highest to the lowest?

- (1) Q, R, P
  - (2) P, R, Q
  - (3) Q, P, R
  - (4) R, P, Q
- 19 The table below shows the melting and boiling points of three substances, X, Y and Z.

Substance	Melting point ( $^{\circ}\text{C}$ )	Boiling point ( $^{\circ}\text{C}$ )
X	10	70
Y	30	85
Z	55	125

Which substances X, Y and Z is/are liquids at  $80^{\circ}\text{C}$ ?

- (1) X only.
- (2) Z only
- (3) X and Y only
- (4) Y and Z only

- 20 Liwei placed a glass mug and a wooden bowl into the refrigerator overnight. The next morning, he removed both the mug and the bowl from the refrigerator at the same time. The glass mug felt colder than the wooden bowl.

Which of the following explains why the mug felt colder than the bowl?

- (1) The bowl conducted heat slower than the mug.
  - (2) The mug was a poorer conductor of heat than the bowl.
  - (3) The mug and the bowl were at different temperatures.
  - (4) The bowl had a larger exposed surface area than the mug.
- 21 Nurah used a magnet to hold a piece of paper onto her refrigerator as shown below.

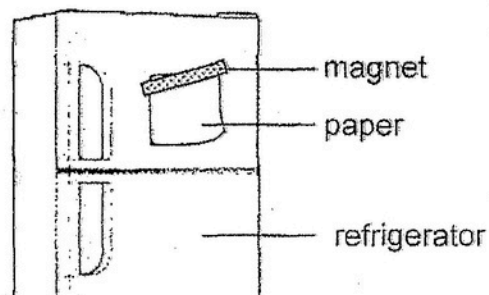

Which of the following statements is/are correct?

- A There is no gravitational force acting on the paper.
  - B There is friction between the paper and the magnet.
  - C There is magnetic attraction between the refrigerator and the magnet.
- (1) C only
  - (2) A and B only
  - (3) B and C only
  - (4) A, B and C

- 22 Diva placed a block of wood on surface T as shown below. She recorded the mass needed to move the wooden block across the surface.

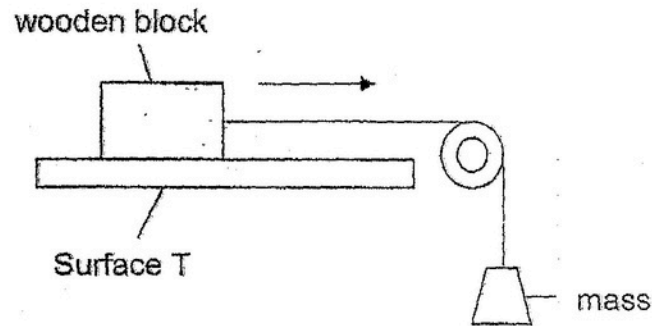

She repeated her experiment with surfaces U and V. She recorded her results below.

Surface	Mass needed to move block (g)
T	350
U	50
V	200

Based on Diva's results above, which of the following best represents surfaces T, U and V respectively?

	Surface T	Surface U	Surface V
(1)	glass	sandpaper	cardboard
(2)	cardboard	glass	sandpaper
(3)	sandpaper	cardboard	glass
(4)	sandpaper	glass	cardboard

- 23 Gina conducted an experiment with objects J, K and L of the same mass. She attached each object to a spring, one at a time.

Diagram 1 shows the length of the spring at the start of the experiment when an object is hung on it. In Diagram 2, she placed a magnet under each object and measured the length of the spring.

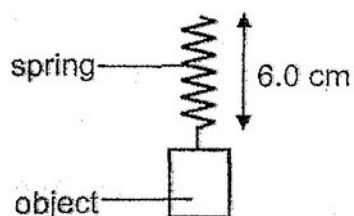

Diagram 1

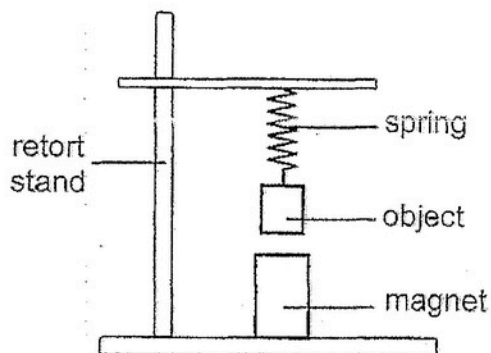

Diagram 2

Her results are shown in the table below.

Object	Length of spring (cm)
J	5.5
K	6.8
L	6.0

Based on the results above, what could objects J, K and L be?

	J	K	L
(1)	magnet	iron bar	plastic bar
(2)	magnet	magnet	iron bar
(3)	plastic bar	magnet	magnet
(4)	plastic bar	iron bar	magnet

- 24 A ball was released from point P, as shown in the diagram below. The ball rolled past points Q and R before coming to a stop at point S.

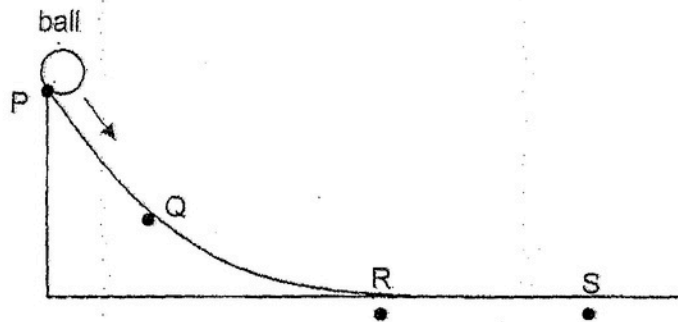

Which of the following best shows the changes in the potential energy and the kinetic energy of the ball from point P to point S?

Key: potential energy ———  
kinetic energy - - - - -

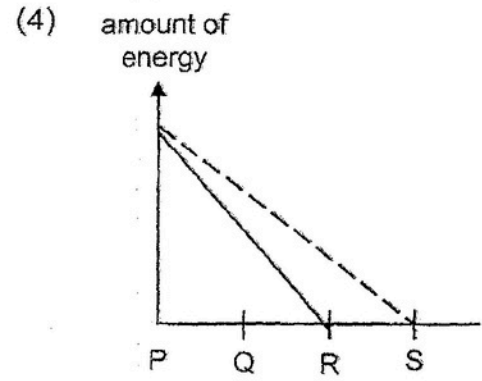
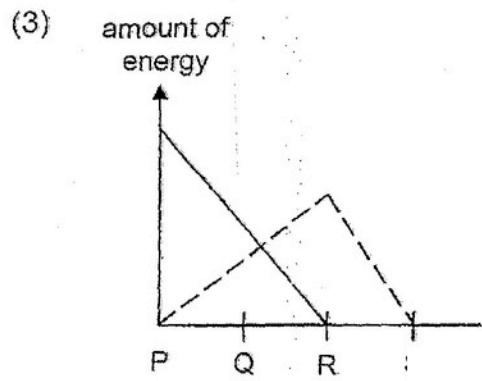
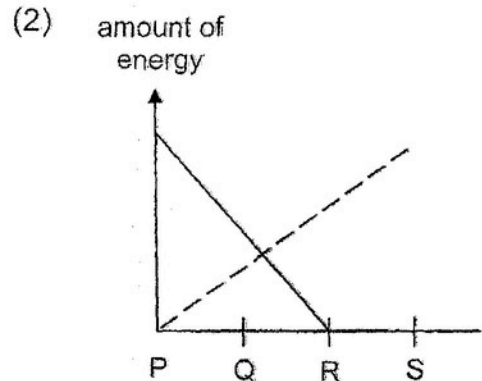
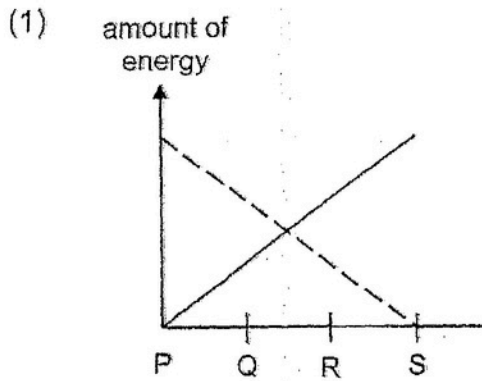

- 25 Chris set-up an experiment to examine four different types of springs, W, X, Y and Z.

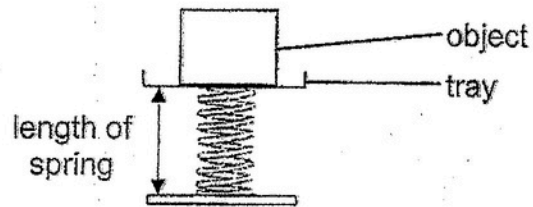

He placed objects of different mass on each spring and recorded the length of the spring. The results are shown in the graph below.

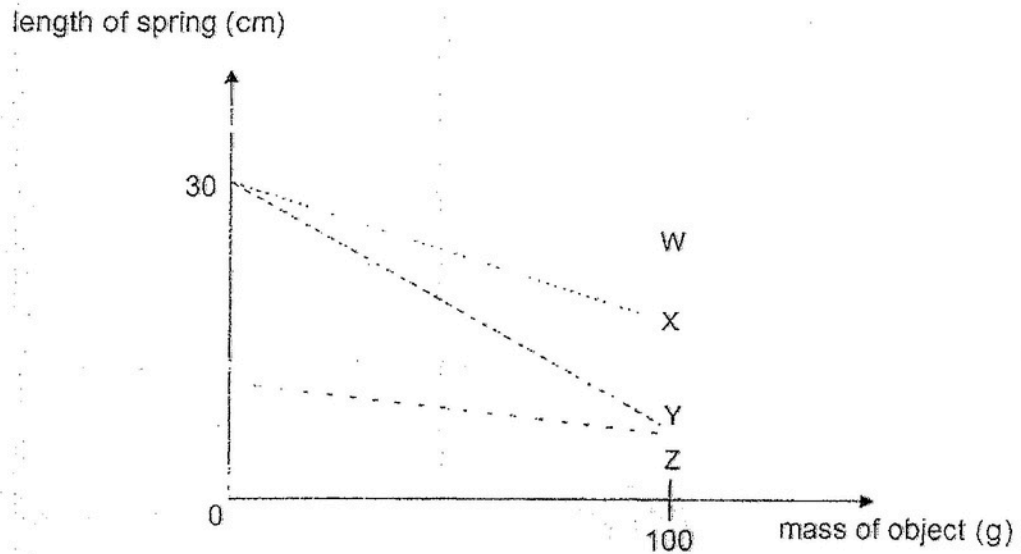

Chris was given two blocks of different materials, A and B, and each having a mass of less than 100 g.

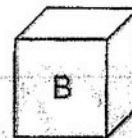
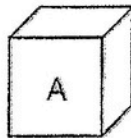

Using the same set-up, which spring, X, W, Y or Z, should be used to compare the mass of the two blocks most accurately?

- (1) W
- (2) X
- (3) Y
- (4) Z

26 Amanda bent three pieces of wire into shapes W, X and Y as shown below.

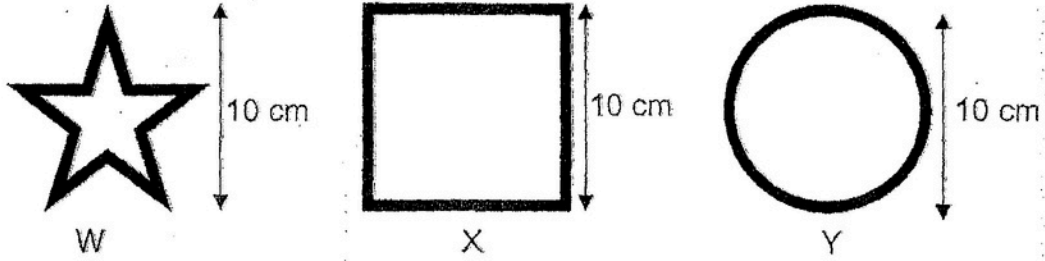

The shapes were hung at different distances from a torch as shown in the diagram below.



Which of the following shows the shadow formed from the above arrangement?

(1)

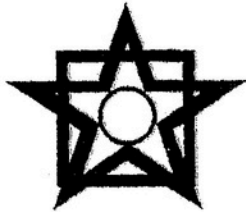

(2)



(3)

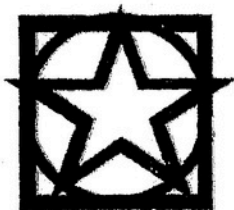

(4)

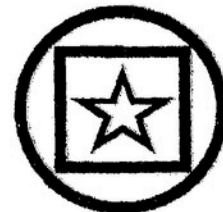

- 27 Rachel has an electronic device which she wears to cool herself down on a hot day.

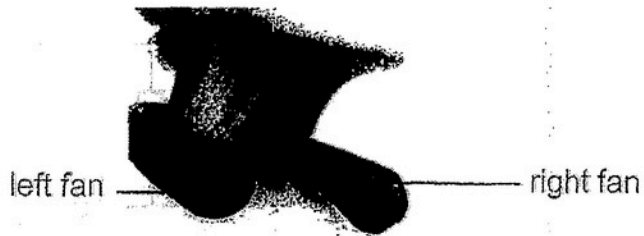

The device has three switches. The following describes how it works:

- One switch control both fans.
- One switch controls the left fan only.
- One switch controls the right fan only.
- When one fan is faulty, the other fan continues to work.

Which of the following electric circuits correctly shows how the electronic device above works?

(A)

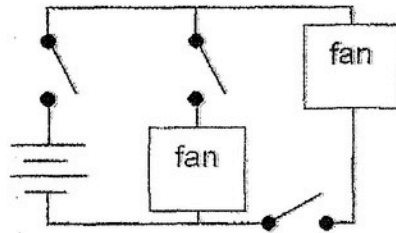

(B)

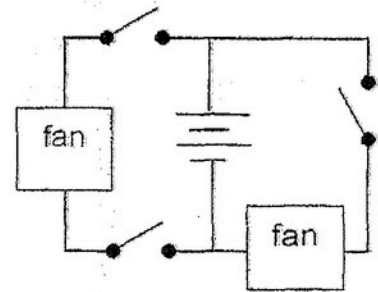

(C)

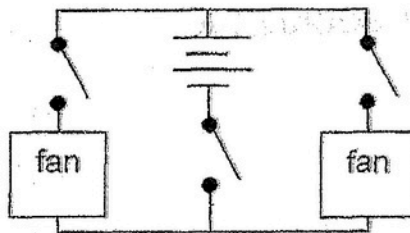

(D)

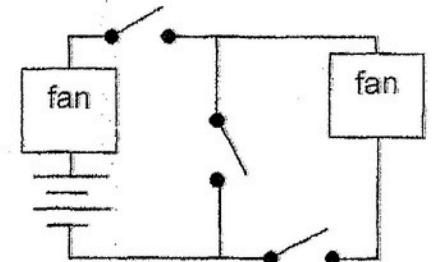

- (1) A and C only
- (2) A and D only
- (3) B and C only
- (4) C and D only

28 Faizal set up a circuit as shown below. All the components are working properly.

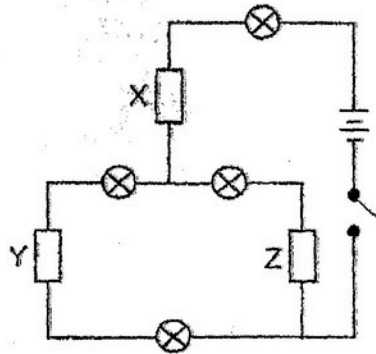

He observed that only three bulbs lit up when the switch was closed.

Based on Faizal's observation, which of the following objects is/are conductor(s) of electricity?

- (1) X only
- (2) Z only
- (3) X and Y only
- (4) Y and Z only

**END OF BOOKLET A**

Name: \_\_\_\_\_ ( )

26 August 2025

Class: Primary 6 SY / C / G / SE / P



SINGAPORE CHINESE GIRLS' SCHOOL  
PRELIMINARY EXAMINATION 2025

**PRIMARY 6**

**SCIENCE**

**BOOKLET B**

Total Time for Booklets A and B: 1h 45 min

**INSTRUCTIONS TO CANDIDATES**

1. Write your Index No. in the boxes at the top right-hand corner.
2. Do not turn over this page until you are told to do so.
3. Follow all instructions carefully.
4. Answer all questions.

This booklet consists of 15 printed pages.

For questions 29 to 40, write your answers in this booklet. The number of marks available is shown in brackets [ ] at the end of each question or part question. (44 marks)

29 (a) State one function of leaves. [1]

---

---

Patrick removed the food-carrying tubes from the stems of two similar plants A and B in the garden as shown below. The plants were watered every day.

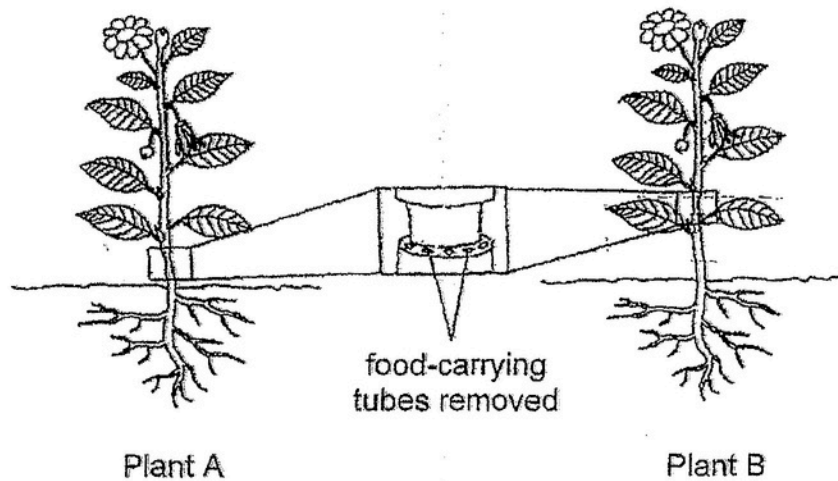

Their growth was observed over a month.

(b) Explain why Plant A died and Plant B survived. [2]

Plant A:

---

---

---

Plant B:-

---

---

---

30 Peili saw animal K in the garden feeding on the leaves of a plant.

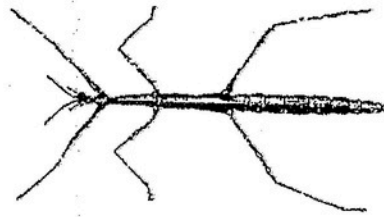

animal K

(a) What animal group does K belong to? Give a reason for your answer. [1]

---

---

(b) Identify the type of adaptation displayed by animal K by putting a tick (✓) in the correct column. [1]

Peili's observation	Type of adaptation	
	Behavioural	Structural
body structure that looks like a twig		
rocking side to side while walking		

(c) Explain how looking like a twig protects animal K from predators. [1]

---

---

- 31 (a) State the function of the respiratory system. Include in your answer the gases involved. [1]
- 

- (b) Aiman was attending a swimming lesson. The graphs below show how his heart rate and breathing rate changed during the lesson. At time = 0 min, he was at rest.

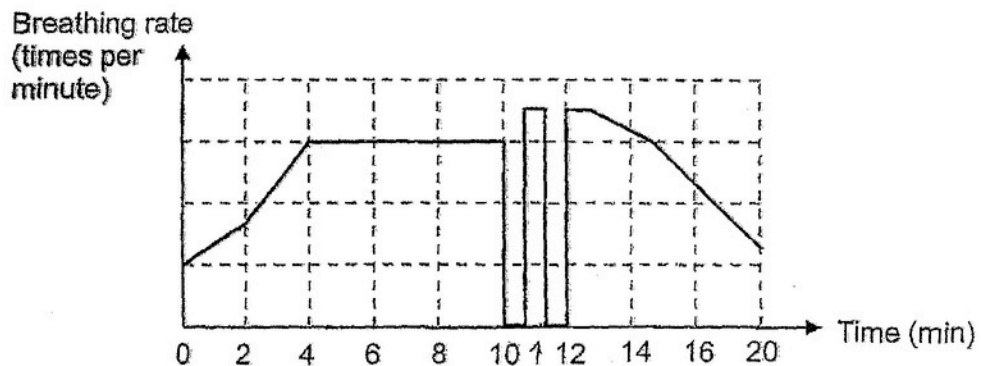
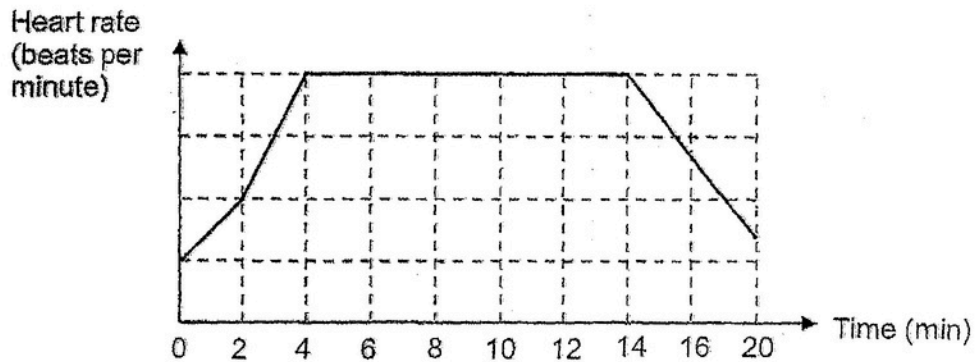

- (i) Explain why his heart rate increased while he was swimming. [2]

---

---

---

- (ii) As part of his swimming lesson, Aiman had to stay underwater. Based on the graphs given, how many times did Aiman have to stay underwater during the lesson? [1]

---

SCORE

- 32 Adele observed four cells, W, X, Y and Z, under a microscope and recorded her observations in the table below. A tick (✓) indicates the presence of the cell part.

Cell part	Cell W	Cell X	Cell Y	Cell Z
Cell wall	✓		✓	
Nucleus	✓		✓	✓
Chloroplast			✓	
Cell membrane	✓	✓	✓	✓

- (a) Based on her observations, which of the above cell(s) is/are likely to be a plant cell? Give a reason for your answer. [2]

---

---

Adele then observed the cells over a period of time. She recorded her observations in the graph below.

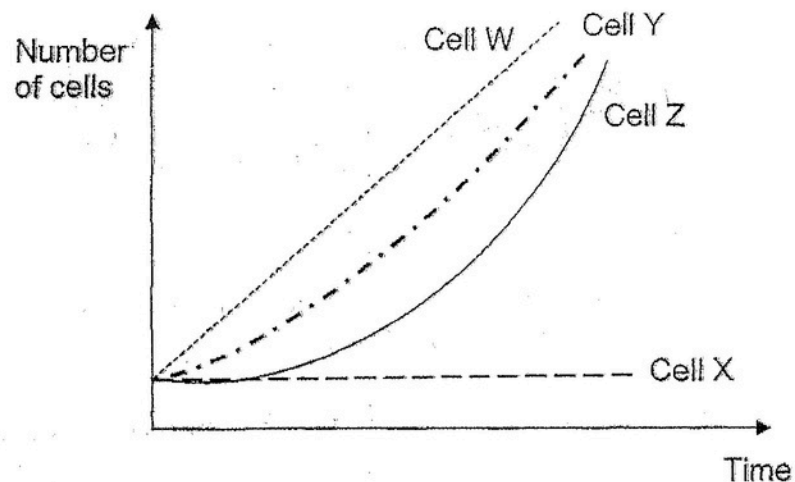

- (b) Based on the table and the graph, what can Adele conclude about the function of the nucleus? [1]

---

(Question 32 continues on the next page.)

SCORE	3
-------	---

Cell P is a single-cell organism that can trap light to make food. Xiao Ming placed an equal volume of liquid R containing some cell P into three identical containers, A, B and C. He placed the containers at different distances away from the tube lamp.

Liquid R changes colour according to the amount of carbon dioxide present.

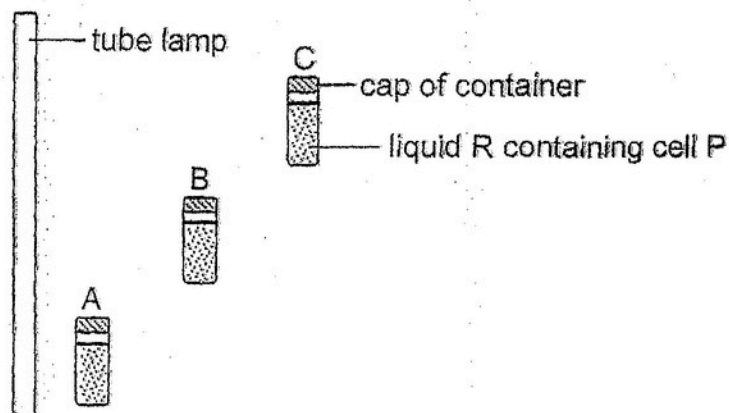

Each number below represents a different colour.

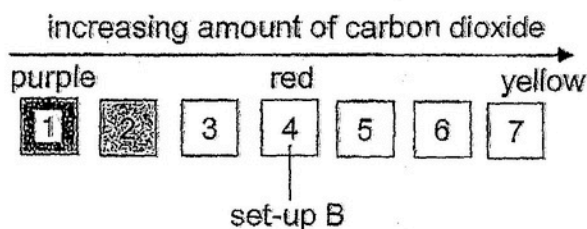

Xiao Ming observed the colour of liquid R in the three containers after an hour. The colour of liquid R in set-up B is 4.

Suggest a number for the colour of liquid R in containers A and C. [1]

(c) Container A: \_\_\_\_\_ Container C: \_\_\_\_\_

(d) Suggest one reason that could have resulted in Xiao Ming obtaining inaccurate colour change in liquid R in his three set-ups. [1]

\_\_\_\_\_

\_\_\_\_\_

33 Study the information below about organisms P, Q, R and S.

P	Q	R	S
depends on S to disperse its seeds	feeds on S	lays eggs on P for its young to eat	feeds on P and R

(a) Based on the information provided, complete the food web below by writing P, Q, R and S in the correct boxes. [1]

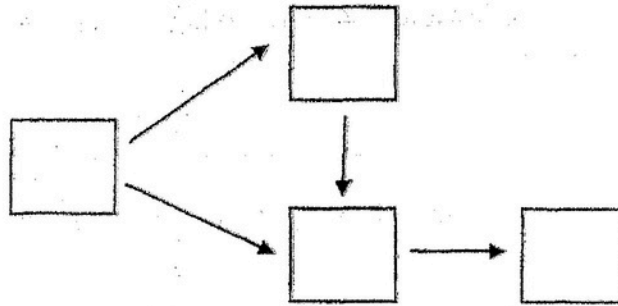

(b) The diagram below shows organism S.

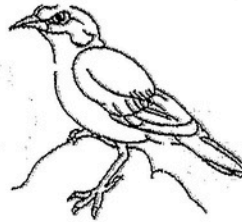

organism S

Anand observed that in areas where there are coffeeshops or hawker centres, organism S prefers to feed on uneaten food instead.

Suggest what will likely happen to the population of organism P in such areas. Explain your answer. [2]

---



---



---

- 34 The diagram below shows a tea dispenser in a box to keep drinks warm.

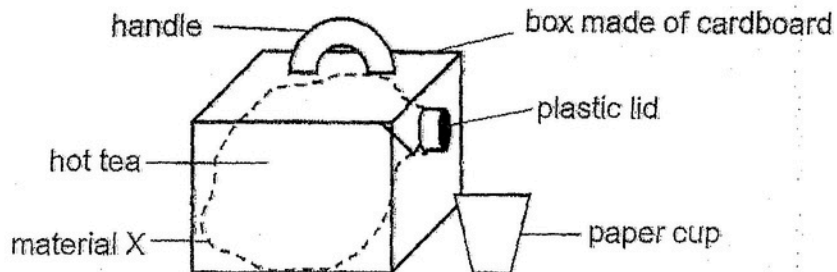

- (a) Besides being flexible to fit into the box, state one other property that material X must have. [1]

---

- (b) State one advantage of using cardboard instead of metal to make the box. [1]

---

Sally then set up the experiment below to find out which material, X, Y or Z, was best for keeping the tea hot.

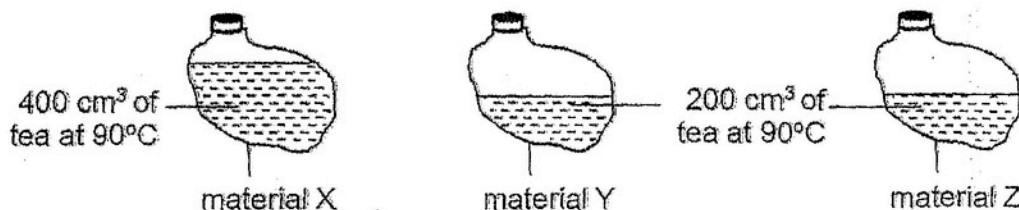

She measured the temperature of the tea after 30 minutes and recorded her results in the table below.

Tea in material	Amount of tea (cm <sup>3</sup> )	Temperature of tea (°C)	
		At the start	After 30min
X	400	90	75
Y	200	90	62
Z	200	90	53

(Question 34 continues on the next page.)

SCORE	/
-------	---

- (c) Based on the results above, can she conclude that material X is the best for keeping the tea hot for the longest time? Explain your answer. [1]

---

---

- (d) Which material, Y or Z, is better for keeping the tea hot longer? Explain your answer. [1]

---

---

35 Kai Yun made a magnetic toy to be displayed at the school science fair.

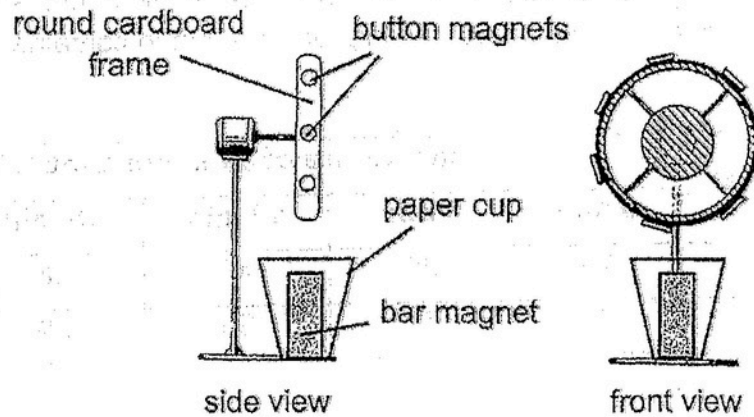

- (a) When Kai Yun placed the paper cup containing the bar magnet under the round cardboard frame, the round cardboard frame began to spin on its own. Explain why this happened. [1]

---

---

- (b) Without removing or replacing any of the items, what can Kai Yun do to make the round cardboard frame spin faster? Explain your answer clearly. [2]

---

---

---

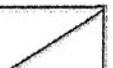

- 36 Vanessa wanted to find out how colour of surface affects the rate at which heat is absorbed. She conducted an experiment using two containers, K and L, as shown below. Container K has a black surface while container L has a white surface.

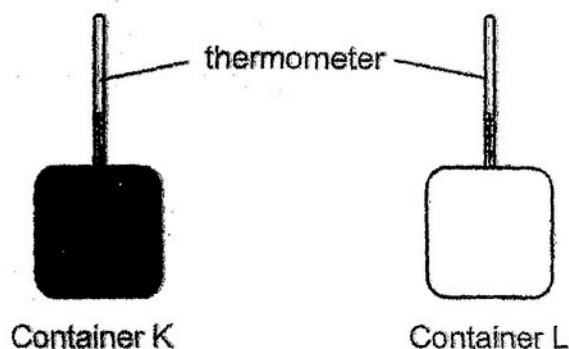

She placed both containers under the sun. After a few hours, she observed that the temperature in container K was higher than that in container L.

Container	Temperature of air in container ( $^{\circ}\text{C}$ )				
	0 min	5 min	10 min	15 min	20 min
K	28	35	42	46	46
L	28	32	36	39	43

- (a) Based on her results, what can Vanessa conclude from her experiment? Give a reason for your answer. [1]

---

---

- (b) Suggest a reason why the temperature of air in container K remained constant after 15 minutes. [1]

---

---

(Question 36 continues on the next page.)

SCORE	/
-------	---

Animal Z lives in a hot and sandy place.

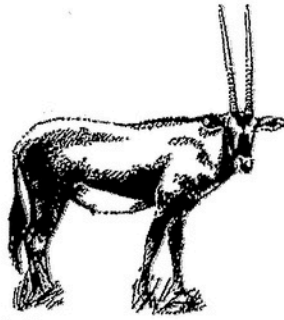

Animal Z

- (c) Explain how having a white outer covering benefits animal Z. [1]

---

---

On cold nights, animal Z will rest inside a hole it digs instead of resting on top of sandy ground.



- (d) Suggest how this behaviour helps to keep animal Z warm. [1]

---

---

---

- 37 A light-up yo-yo is a yo-yo which is equipped with an LED light that lights up when the yo-yo is in motion. When the yo-yo is thrown and starts spinning, the force at which it is thrown causes the lights to come on.

The diagram below shows a girl playing with a light-up yo-yo.

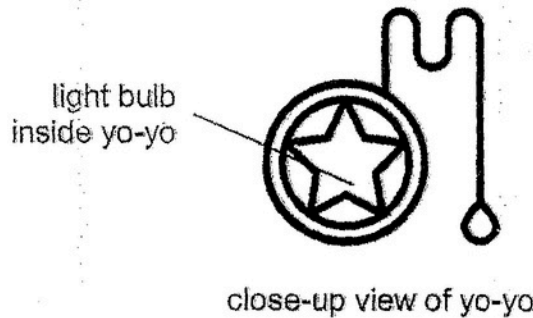

- (a) Fill in the blanks to show the energy conversions when the yo-yo is released from the girl's hand. [2]

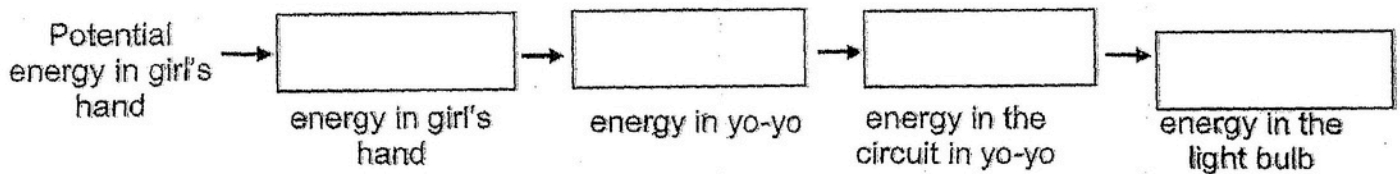

- (b) The girl noticed that the yo-yo lit up dimly when the yo-yo was not fully extended. Explain why. [1]

---



---

- (c) Without replacing any component in the yo-yo, suggest a way to make the yo-yo light up more brightly. [1]

---

38 Fabian created a steam table to keep food warm.

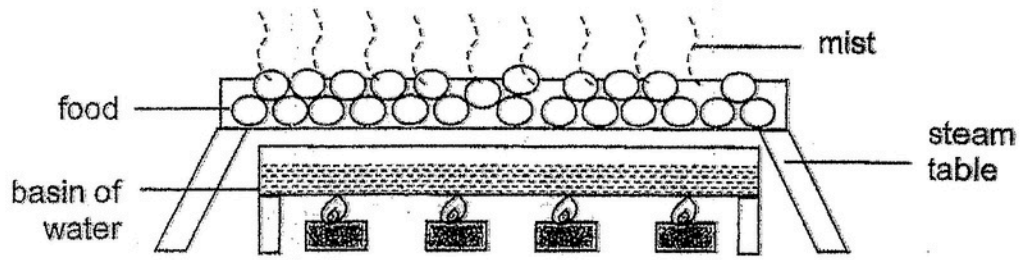

(a) Fabian observed mist forming above the food after some time. Explain his observation. [2]

---

---

---

(b) Fabian realised he had to top up the water in the basin frequently when the steam table was in use. He decided to modify the set-up by adding a metal lid as shown below.

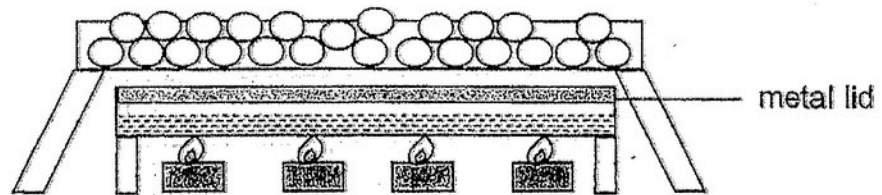

Explain how adding the metal lid helps to reduce the need to top up water in the basin. [1]

---

---

39 The diagram below shows a scooter with three lamps, P, Q and R.

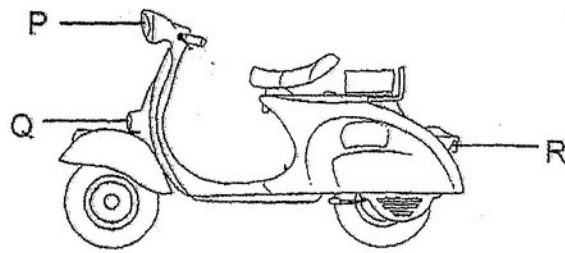

Circuit X shows how the lamps are connected.

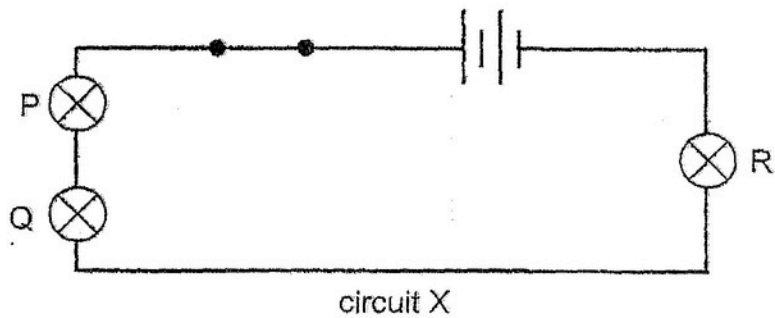

- (a) Based on circuit X, explain why it is not safe to ride the scooter at night if lamp Q fuses. [1]

---

---

(Q39 continues on the next page.)

SCORE	/
-------	---

- (b) Circuit Y is used to improve the safety of the scooter. Complete circuit Y below to show how the lamps should be connected such that it is safe to use the scooter at night even if one of the lamp fuses. [2]

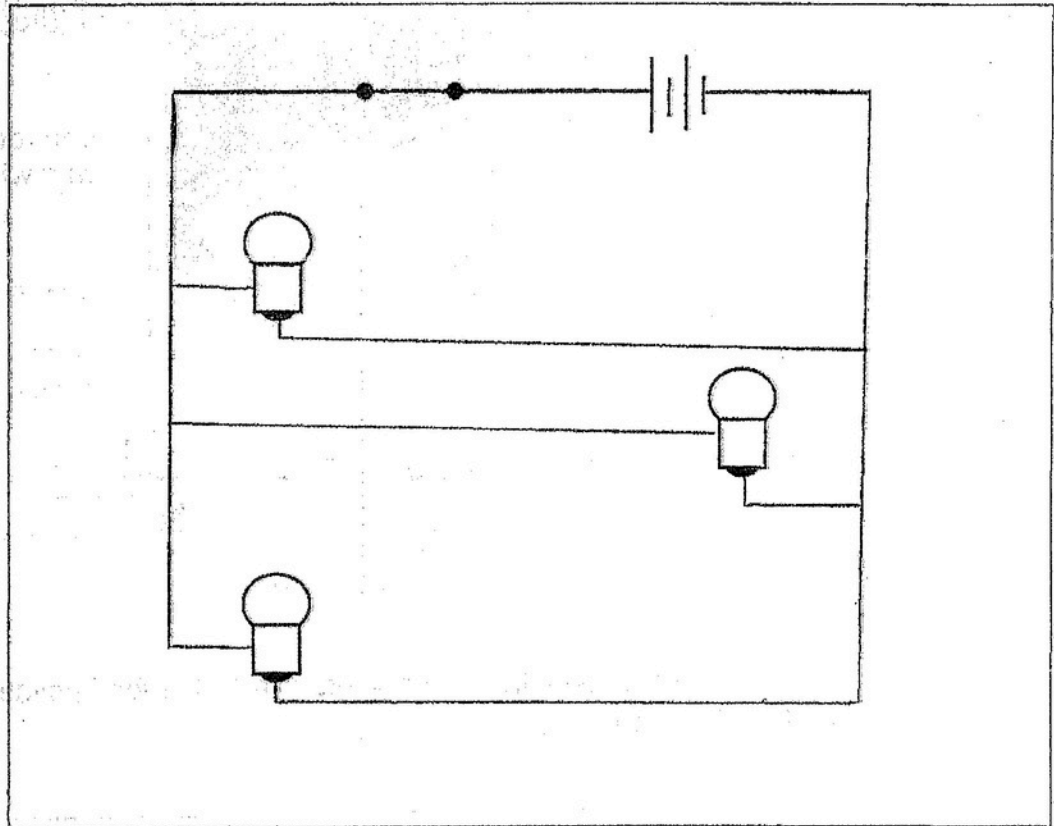

- (c) State another advantage of using circuit Y. [1]

---

SCORE	
-------	--

- 40 The diagram below shows a food dispenser used to feed a pet when the pet owner is away. The food tray is attached to the metal bar.

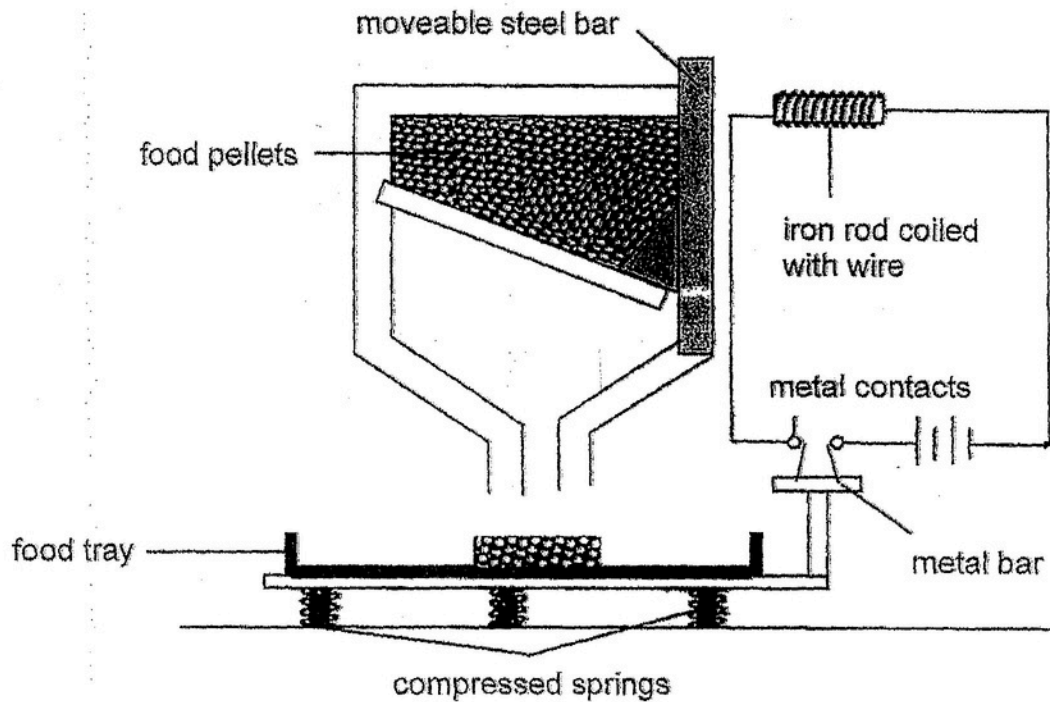

- (a) Explain how the food dispenser works to refill the food pellets when there is no food left in the tray. [2]

---



---



---

- (b) Amelia replaced the moveable steel bar with another object made of material X. The set-up could not work at all this time. Explain why. [1]

---

- (c) Suggest a possible change to the spring to refill the food tray before there is no food in the tray. [1]

---

END OF BOOKLET B

SCORE	/
-------	---

SCHOOL : SINGAPORE CHINESE GIRL'S PRIMARY SCH  
 LEVEL : PRIMARY 6  
 SUBJECT : SCIENCE  
 TERM : PRELIMINARY EXAMINATION

Booklet A

Q1	Q2	Q3	Q4	Q5	Q6	Q7	Q8	Q9	Q10
1	1	3	3	2	2	1	2	2	3
Q11	Q12	Q13	Q14	Q15	Q16	Q17	Q18	Q19	Q20
1	2	2	2	4	4	3	1	4	1
Q21	Q22	Q23	Q24	Q25	Q26	Q27	Q28		
3	4	1	3	3	4	1	3		

Booklet B

29	<p>(a) Concept: the functions of plant parts          Make food / carry out photosynthesis / carry out gaseous exchange</p> <p>(b) Concept: Function of food and water carrying tubes in plant transport system          Plant A: Food (made in the leaves) could not be transported to the roots.          Plant B: Food could still be transported from the leaves below the cut part to the roots.</p> <p>(a) Concept: Recognise some broad groups of living things.</p>						
30	<ul style="list-style-type: none"> <li>• Insect</li> <li>• It has (any one of the following):             <ul style="list-style-type: none"> <li>○ six legs / 3 pairs of legs / 3 body parts</li> </ul> </li> </ul> <p>b) Concept: Recognise that adaptations serve to enhance survival and can be structural or behavioural – to escape from predators.</p> <table border="1" style="width: 100%;"> <thead> <tr> <th>Peter's observation</th> <th>Type of adaptation</th> </tr> </thead> <tbody> <tr> <td>Body structure that looks like a leaf</td> <td>Structural</td> </tr> <tr> <td>Rocking back and forth while walking</td> <td>Behavioural</td> </tr> </tbody> </table>	Peter's observation	Type of adaptation	Body structure that looks like a leaf	Structural	Rocking back and forth while walking	Behavioural
Peter's observation	Type of adaptation						
Body structure that looks like a leaf	Structural						
Rocking back and forth while walking	Behavioural						

31	<p>(a) Concept: Function of respiratory system</p> <ul style="list-style-type: none"> <li>To take in oxygen and remove carbon dioxide from the body.</li> </ul> <p>(b)(i) Concept: Recognise the integration of the different systems (digestive, respiratory and circulatory) in carrying out life processes.</p> <ul style="list-style-type: none"> <li>His heart rate increased to transport more oxygen and digested food (to all parts of his body) and to remove carbon dioxide / waste materials.</li> </ul> <p>(b)(ii) Skill: Inferring from a line graph. 2 / two</p> <p>(a) Skill: Cell parts and functions</p>
32	<p>W and Y. They have cell wall.</p> <p>(b) Concept: Cell parts and functions. The nucleus enables the cell to divide.</p> <p>(c) Concept: Investigate the factors that affect photosynthesis and communicate findings. Container A: 1 / 2 / 3 Container C: 5 / 6 / 7</p> <p>(d) Concept: Evaluating fair test</p> <ul style="list-style-type: none"> <li>There is a different number/ amount of organism X. OR</li> <li>The amount of carbon dioxide at the start is different.</li> </ul>
33	<p>(a) Concept: Trace the energy pathway from the Sun through living things: identify the roles of various organisms in a food chain and a food web.</p> <div style="text-align: center;"> <pre> graph TD     P --&gt; R     P --&gt; S     R --&gt; S     S --&gt; Q </pre> </div> <p>(b) Skill: Make inferences based on interactions between organisms in a food web. C: The population of P will decrease. E: There are fewer S R: Less seeds of P will be dispersed</p> <p>(a) Concept: Relate the properties of materials to their uses</p>
34	<p>Waterproof / poor conductor of heat / strong</p>

	<p>(b) Concept: Relate the properties of materials to their uses Cardboard is lighter than metal. / Cardboard is a poorer heat conductor than metal.</p> <p>(c) Skill: Evaluating fair test No. Y and Z have less tea than X so there is less heat in the tea. They take a shorter time to lose heat to the surroundings.</p> <p>(d) Concept: Poor conductor of heat Material Y. After 30 min, the temperature of the tea is higher than the temperature of tea in Material Z. The tea in Material Y has lost less heat than tea in Material Z.</p> <p>(a) Concept: Like poles of magnets repel</p>
35	<p>The like poles of the bar magnet in the cup and the button magnets are repelling.</p> <p>(b) Concept: Magnetic repulsion Add more button magnets on the frame with the like poles facing away from the bar magnet so there is greater repulsion / pushing force.</p> <p>(a) Concept: Drawing conclusions from experimental data. <del>Black absorbs heat more quickly than white.</del></p>
36	<p>(b) Concept: Heat flows from a hotter to a colder object/region until both reach the same temperature. The temperature of air has reached the same temperature as the surroundings.</p> <p>(c) Concept: Recognise that adaptations serve to enhance – cope with physical factors Animal Z will gain heat more slowly from the environment to keep itself cool.</p> <p>(d) Concept: Recognise that adaptations serve to enhance – cope with physical factors Less surface area of animal Z's body will be exposed to the cold so it will lose less heat to its surroundings.</p> <p>(a) Concept: energy conversion KE, KE, EE, LE</p> <p>(b) Concept: Trace energy conversion from one form to another.</p>
37	<p><del>There is not enough KE to be converted to EE to light the yoyo brightly when it was not fully extended.</del></p>

	<p>(c) Skill: Investigate energy conversion from one form to another. Push the yoyo harder when releasing it.</p>
38	<p>(a) Concept: Show an understanding of how water changes state from a gas to liquid. Water vapour / steam from the (hot) food condensed on the cooler surrounding air.</p> <p>(b) Concept: Show an understanding of the roles of evaporation and condensation in the water cycle. Water vapour in the basin will condense on the metal lid and fall back into the basin.</p> <p>(a) Concept: Investigate the effect of some variables on the current in a circuit and communicate findings – number of bulbs arranged in series.</p>
39	<p>If lamp Q fuses, the rest of the lamps will not light up / none of the lamps will light up.</p> <p>(b) Concept: Construct simple circuits.</p> <div data-bbox="347 952 710 1276" data-label="Diagram"> </div> <p>(c) Concept: Investigate the effect of some variables on the current in a circuit and communicate findings – number of bulbs arranged in parallel. The lamps can light up brighter / the brightest possible.</p>
40	<p>(a) Concept: Show an understanding that a current can only flow in a complete circuit.</p> <p>As the amount of food in the tray decreases, the spring extends until the metal bar comes into contact with the probes and closes the circuit. The iron becomes an electromagnet and attracts the moveable steel bar, and the food pellets will drop down to the tray.</p> <p>(b) Concept: Magnetic materials can be magnetised. X is a non-magnetic material and cannot be attracted by the electromagnet.</p> <p>(c) Concept: Design of experiment. Use a longer spring.</p>