



RED SWASTIKA SCHOOL

SCIENCE 2024 PRELIMINARY EXAMINATION PRIMARY 6

Name : _____ ()

Class : Primary 6/ _____

Date : 20 August 2024

BOOKLET A

Total time for Booklets A & B: 1h 45 min

Booklet A: 28 questions (56 marks)

Note:

1. Do not open the booklet until you are told to do so.
2. Read carefully the instructions given at the beginning of each part of the booklet.
3. Do not waste time. If the question is too difficult for you, go on to the next question.
4. Check your answers thoroughly and make sure you attempt every question.
5. In this booklet, you should have the following:
 - a. Page 1 to Page 22
 - b. Questions 1 to 28

For Questions 1 to 28, choose the most suitable answer and shade its number in the OAS provided.

- 1 The table below shows the characteristics of four organisms, A, B, C, and D. A tick (✓) represents the presence of the characteristic.

Characteristics	Organisms			
	A	B	C	D
Has fur	✓			
Lays eggs	✓		✓	✓
Breathes through lungs	✓	✓		✓
Lives on land and in water			✓	

Study the following statements.

- A Organism A is a mammal.
- B Organism B is an amphibian.
- C Organism C is a reptile.
- D Organism D is a bird.

Which statement(s) is/are true?

- (1) D only
- (2) A and D only
- (3) B and C only
- (4) A, B and C only

- 2 Study the following statements. G and H are organisms.

- G produces fruits while H does not.
- G makes its own food while H does not.

What could G and H be?

	G	H
(1)	fern	flowering plant
(2)	fern	fungi
(3)	flowering plant	fern
(4)	flowering plant	fungi

3 The diagram below shows a young plant that has germinated. The young plant was watered daily and placed in an open field.

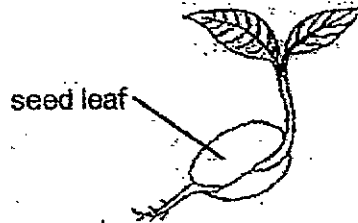

Which of the following shows how the mass of the seed leaf and the leaf will change over time?

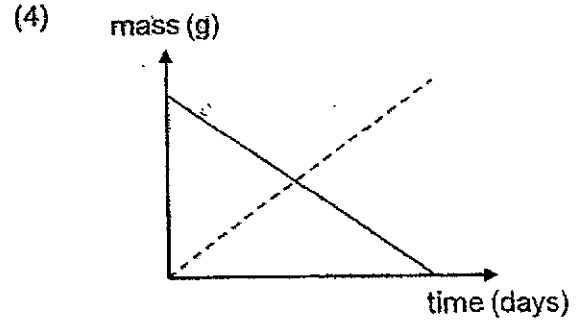
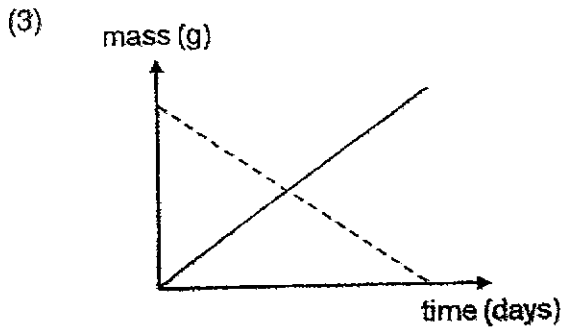
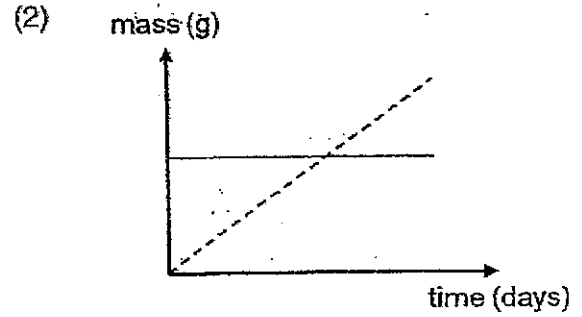
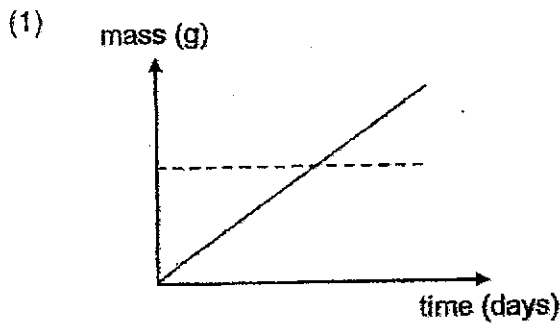
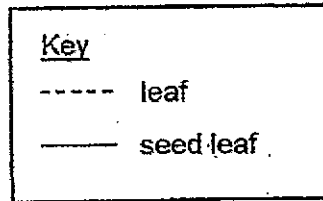

- 4 Kuma predicted that the greater the number of flowering plants in a park, the greater the number of pollinators found in the area.

Which of the following supports his prediction?

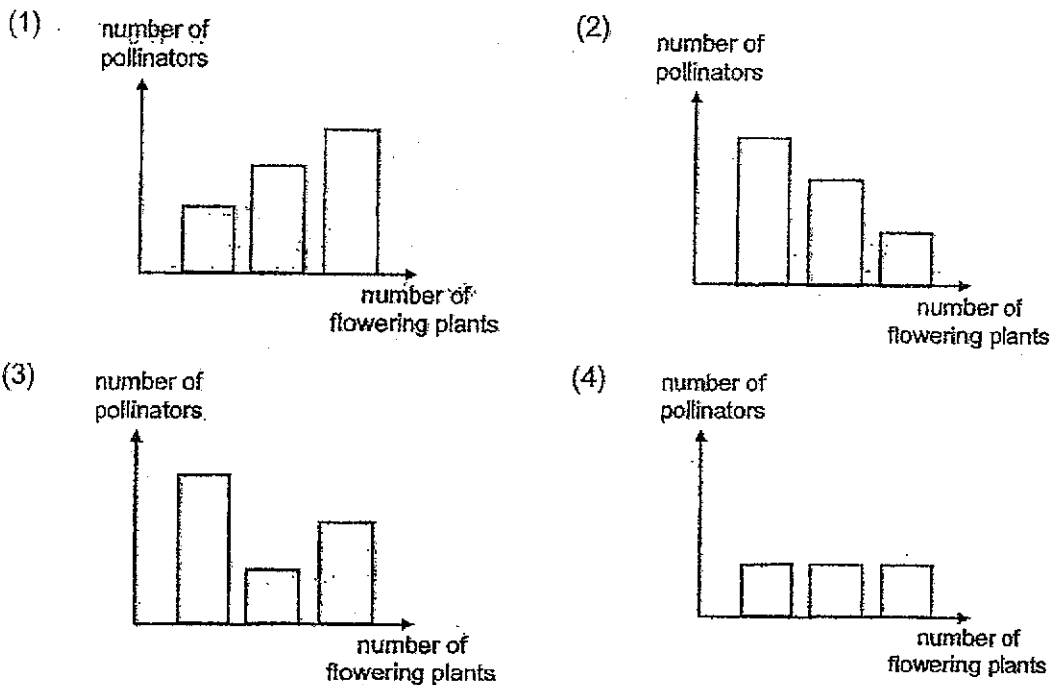

- 5 The following diagram shows the human reproduction process.

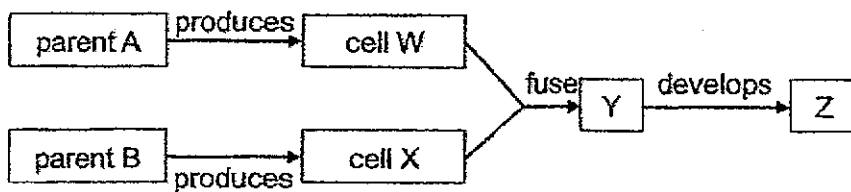

Which of the following contain(s) the characteristics of both parent A and parent B?

- (1) W only
 (2) Z only
 (3) Y and Z only
 (4) W and X only

6 The diagram below shows how substances are transported in the human body.

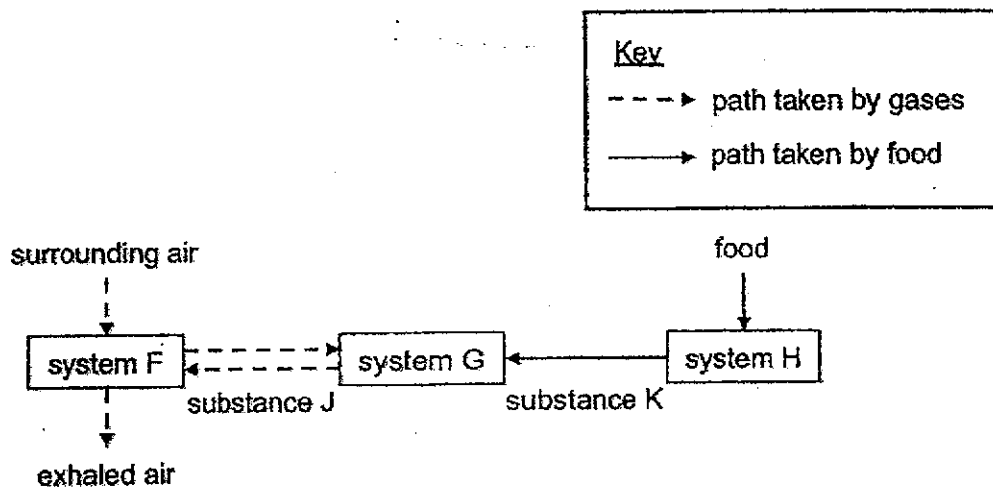

What do systems F, G and H represent and what are substances J and K?

	System F	System G	System H	Substance J	Substance K
(1)	circulatory	respiratory	digestive	oxygen	carbon dioxide
(2)	respiratory	circulatory	digestive	carbon dioxide	digested food
(3)	digestive	respiratory	circulatory	digested food	carbon dioxide
(4)	respiratory	digestive	circulatory	carbon dioxide	digested food

7 Nadine set up the following experiments as shown below and left them by an open window for five days.

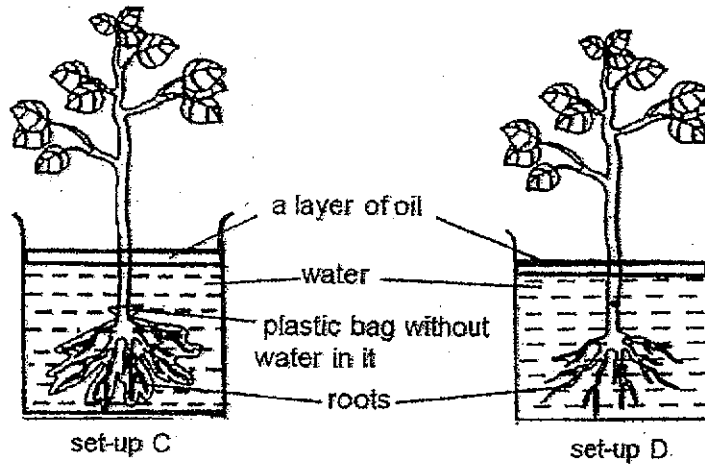

She recorded her observations in the table below.

Set-up	Amount of water in set-ups at the end of the day (ml)				
	Day 1	Day 2	Day 3	Day 4	Day 5
C	500	500	500	500	500
D	500	495	487	480	474

What is the aim of Nadine's experiment?

- (1) To find out if water evaporates.
- (2) To find out if roots take in water.
- (3) To find out if stems support the plant.
- (4) To find out if number of leaves affects water uptake in plants.

- 8 The diagram below shows a carrot plant. It is a plant with an underground storage root.

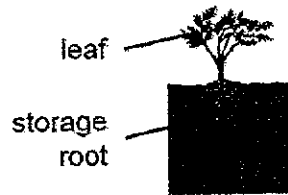

Study the flow chart below.

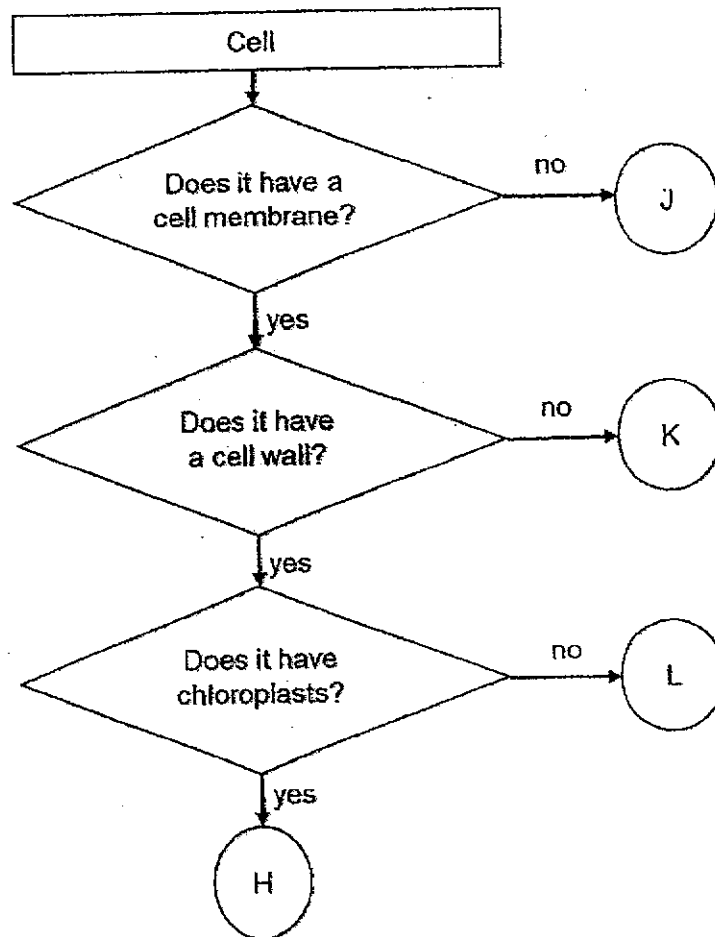

Which of the following, J, K, L or H, represents the leaf and the storage roots?

	storage roots	leaf
(1)	L	H
(2)	K	L
(3)	J	K
(4)	H	J

- 9 The table below shows the amount of plastic waste collected from a coastal area over four months.

Month	Plastic waste (kg)
January	50 000
February	65 000
March	120 000
April	150 000

Based on the data, which of the following statements is most likely true about the plastic waste in the coastal area from January to April?

- (1) There was a significant increase in plastic waste.
- (2) Efforts to reduce plastic waste were highly effective.
- (3) The amount of plastic waste collected remained constant.
- (4) The amount of plastic waste decreased steadily each month.

For questions 10 and 11, refer to the food web below.

The diagram below shows a food web.

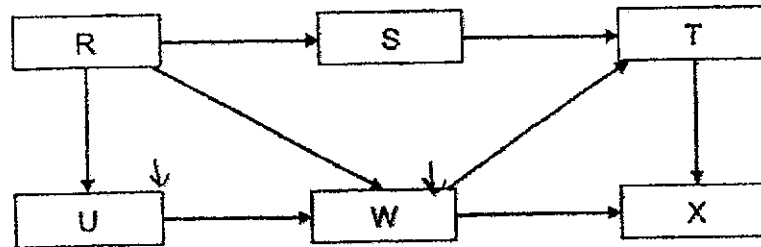

- 10 Which of the following, R, S, T, U, W and X, represents a producer, plant-eater and predator?

	Producer	Plant-eater	Predator
(1)	R	S, U, W	T, X
(2)	U	W	S
(3)	U	S, W	R, T, X
(4)	R	S, U	W, T, X

- 11 Which of the following graphs correctly shows the relationship between the organisms in the food web when population of R decreases?

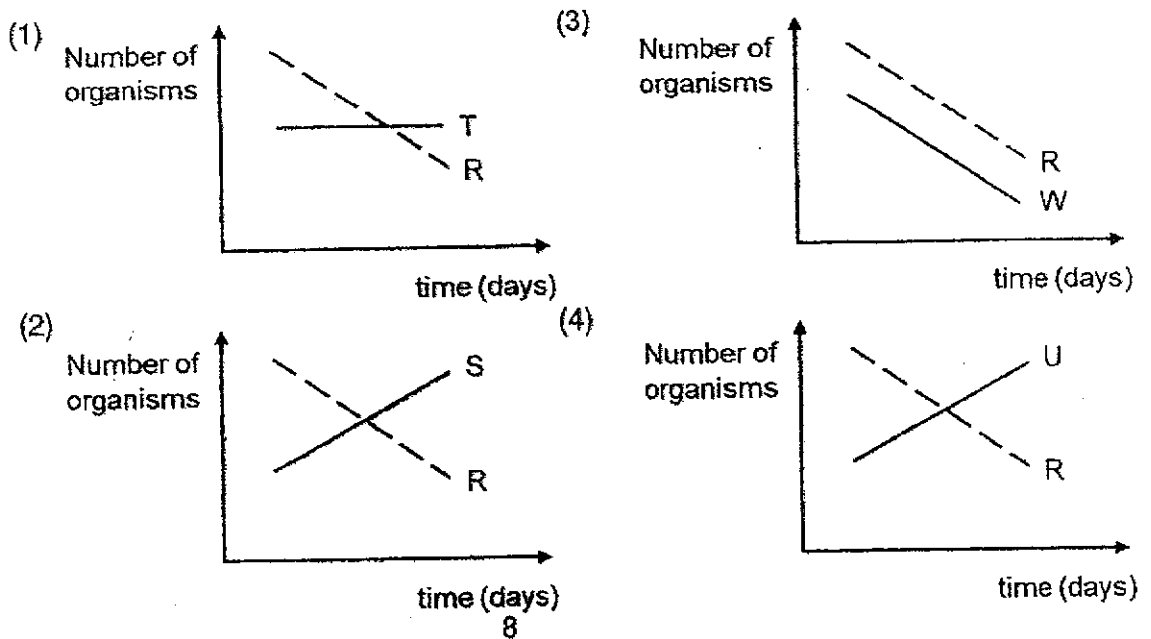

12 Animal L is shown below. It is brown in colour and found in a hot desert.

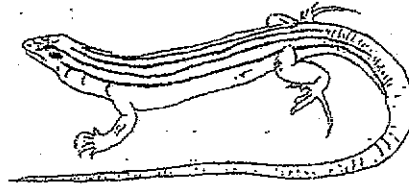

What is/are possible reason(s) why animal L is usually found burrowing in the sand in the desert?

- A To keep itself cool
 - B To hide from its predators
 - C To absorb more heat from the sand
- (1) C only
- (2) A and B only
- (3) B and C only
- (4) A, B and C only

- 13 Lydia placed potted plant Y in a jar next to a window and recorded her observation over a period of time.

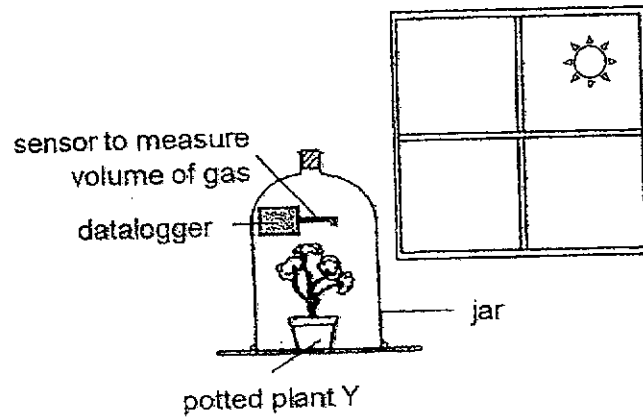

She then plotted the graph below.

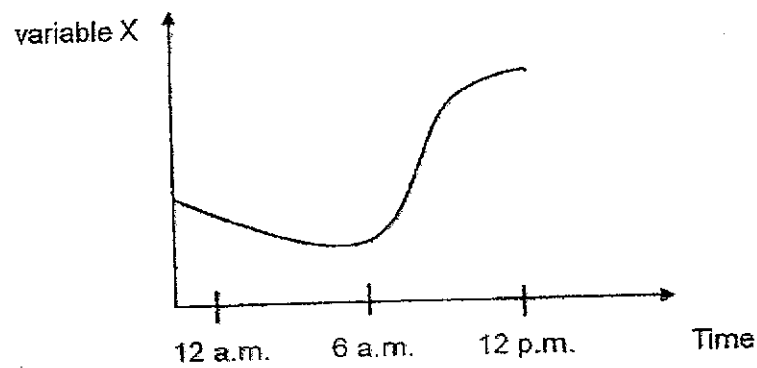

Based on Lydia's experiment and results, what does variable X represent?

- (1) Amount of nitrogen taken in by plant Y
- (2) Amount of oxygen produced by plant Y
- (3) Amount of water vapour taken in by plant Y
- (4) Amount of carbon dioxide taken in by plant Y

- 14 Siti placed four similar set-ups at four different locations, A, B, C and D. For each location, only the intensity of the light was different.

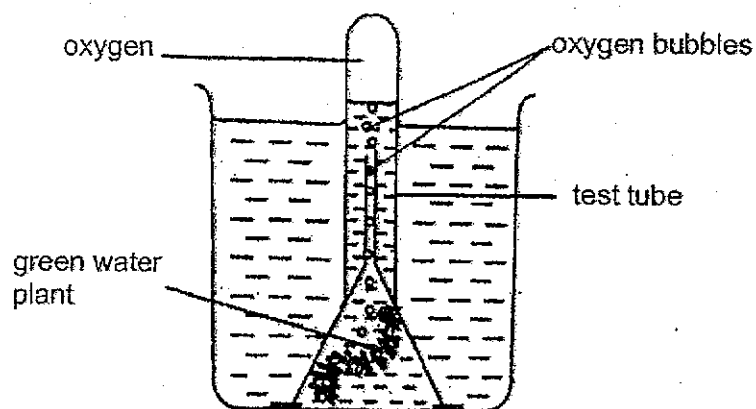

The table below shows the light intensity at the four locations.

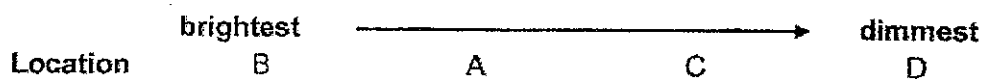

Which of the following correctly shows the amount of oxygen produced (cm^3) by the green water plant at locations A, B, C and D?

Amount of oxygen produced (cm^3) at each location				
	A	B	C	D
(1)	2	5	8	10
(2)	10	8	5	2
(3)	8	10	5	2
(4)	5	2	8	10

- 15 Patricia placed Material X into a tub of water as shown below.

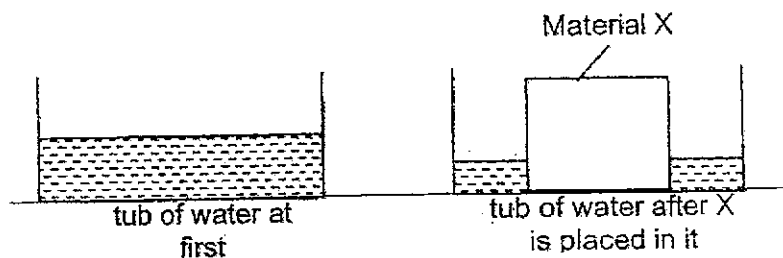

She recorded the volume of water before and after Material X was placed into the water. She repeated the experiment with Material Y, of the same shape and size, and recorded her results in the table below.

	Volume of water at the start (cm ³)	Volume of water at the end (cm ³)
Material X	100	55
Material Y	100	30

Which of the following is correct?

- (1) Material X is waterproof.
 - (2) Material Y is more absorbent than Material X.
 - (3) Material X is more suitable to be used as a towel than Material Y.
 - (4) Material Y is more suitable to be used as a raincoat than Material X.
- 16 Study the diagram of the water cycle below.

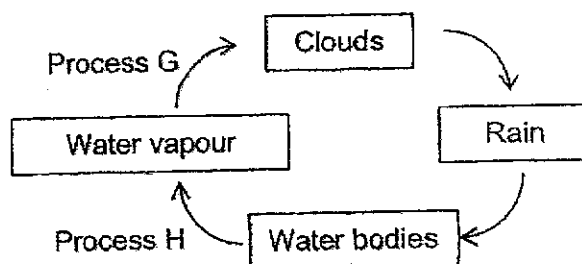

Which of the following is correct?

	Process G	Process H
(1)	Heat is gained	Heat is lost
(2)	Heat is gained	Heat is gained
(3)	Heat is lost	Heat is gained
(4)	Heat is lost	Heat is lost

- 17 Three conical flasks, P, Q and R, with volume of 200 cm^3 each are connected to an air pump as shown below.

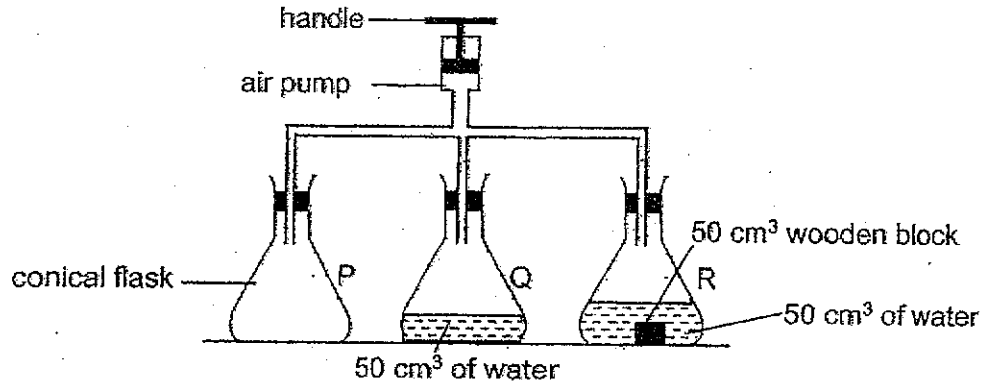

Each time the handle is pushed down, 20 cm^3 of air is pumped into each conical flask. The set-up is designed such that the air cannot flow backwards.

What is the final volume of air in each conical flask if the handle is pushed down once?

	Flask P (cm^3)	Flask Q (cm^3)	Flask R (cm^3)
(1)	200	150	100
(2)	200	170	120
(3)	220	170	100
(4)	220	150	120

18 Dan poured equal volumes of water into three containers, A, B and C, as shown below. He left the containers under the sun at the same location for a few hours.

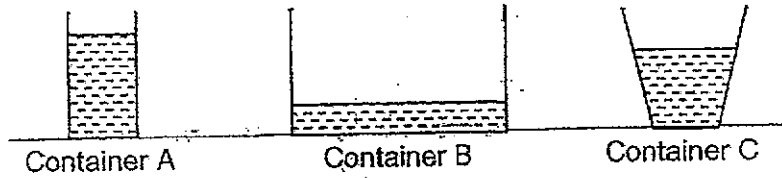

Which of the following graphs represents the volume of water left in the containers after a few hours?

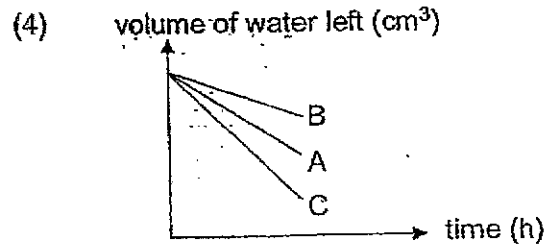
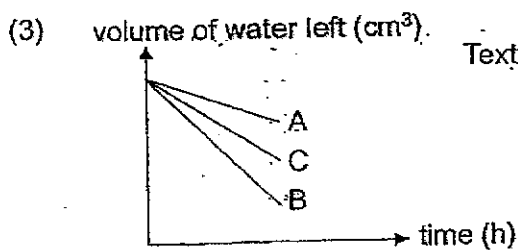
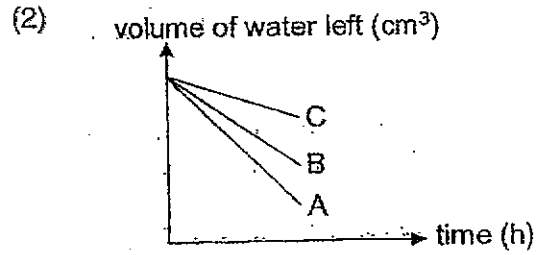
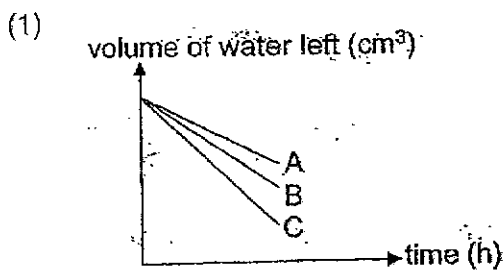

19 Study the four circuits below. All the batteries and bulbs in the four circuits are identical and in working condition.

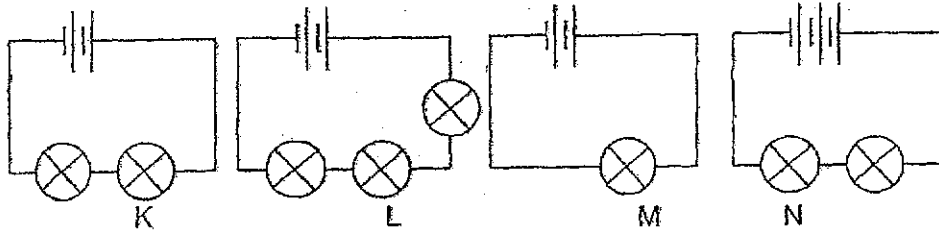

Which of the following shows the correct order of bulbs K, L, M, and N, when arranged from the dimmest to the brightest?

- (1) K, L, M, N
- (2) L, K, N, M
- (3) M, N, L, K
- (4) N, M, K, L

20 The diagram shows a circuit with four open switches.

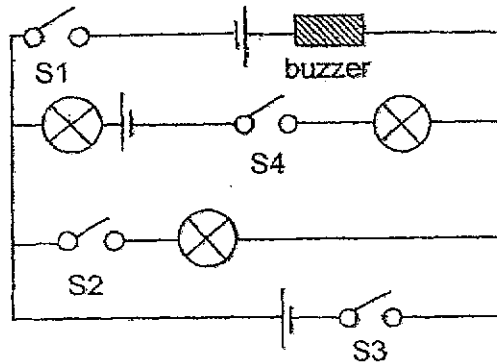

Which of the following will allow the buzzer to sound without any light bulbs lighting up?

	S1	S2	S3	S4
(1)	closed	closed	open	closed
(2)	open	closed	open	closed
(3)	open	open	closed	closed
(4)	closed	open	closed	open

- 21 Four students set up made use of a circuit tester to test two circuit cards.

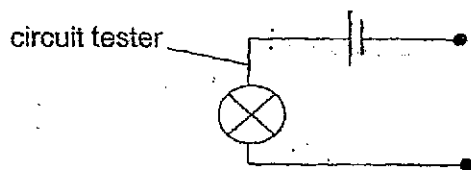

The circuit cards have five points, A, B, C, D and E. Wires are connected to them as shown below.

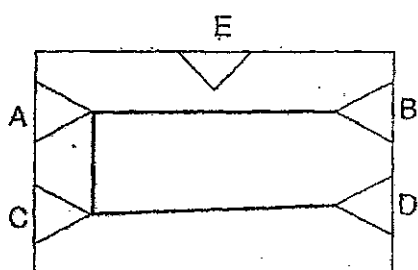

circuit card 1

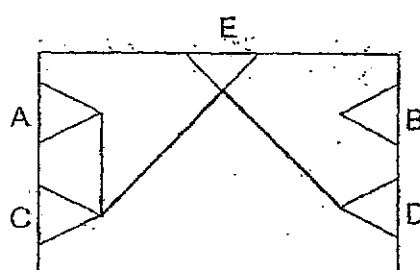

circuit card 2

The four students recorded their results in the table below.

	Points	Circuit card 1	Circuit card 2
Student 1	A and E	Bulb did not light up	Bulb lit up
Student 2	A and D	Bulb lit up	Bulb did not light up
Student 3	B and C	Bulb did not light up	Bulb did not light up
Student 4	B and D	Bulb did not light up	Bulb did not light up

Who made the correct observation?

- (1) Student 1
- (2) Student 2
- (3) Student 3
- (4) Student 4

22. Rods P and Q of similar masses were hung by a string each on the ceiling. When Aminah brought rod P closer to rod Q, Q moved towards P.

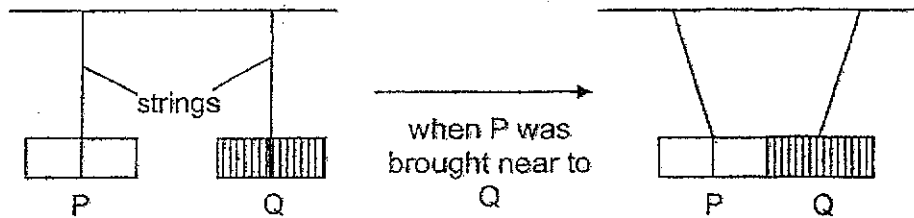

Which conclusion about P and Q is correct?

	P	Q
(1)	magnet	steel
(2)	magnet	aluminium
(3)	copper	magnet
(4)	iron	steel

23. Siti pushed a wooden block down a slope. The wooden block moved down the slope and stopped at W.

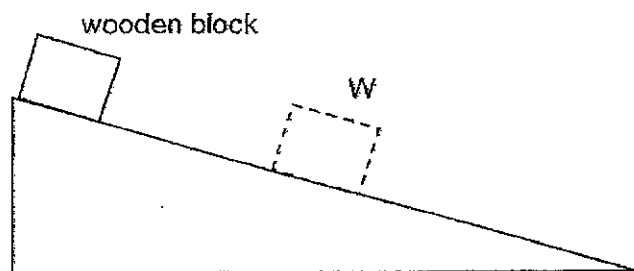

Which force(s) acted on the wooden block?

	Frictional force	Gravitational force
(1)	No	Yes
(2)	No	No
(3)	Yes	Yes
(4)	Yes	No

- 24 Look at the set-up below. Arun hung a magnet at the end of the spring. The length of the spring was 5 cm before he closed the switch.

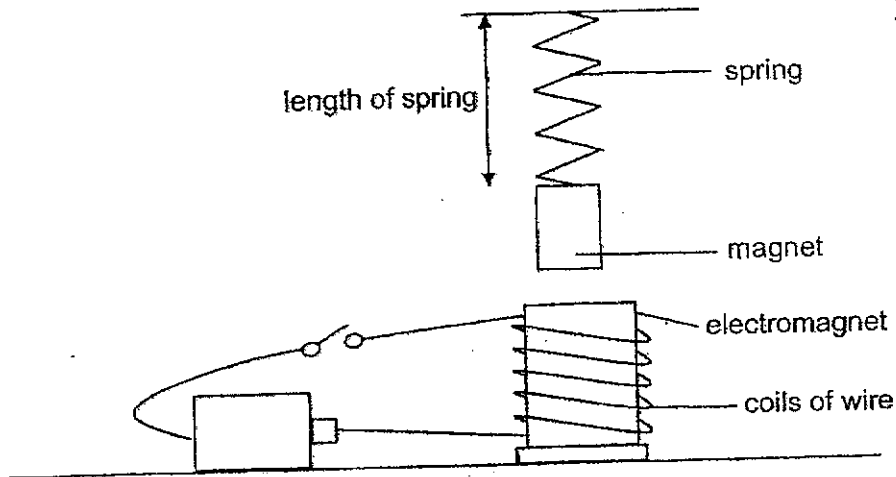

Experiment	Number of batteries used	Direction magnet moved	Length of spring after switch was closed (cm)
A	1	upward	4
B	1	downward	6
C	2	upward	3
D	2	downward	7

Which two experiments support the hypothesis: "When the number of batteries used increases, the poles of the electromagnet will remain unchanged."?

- (1) A and B
- (2) A and D
- (3) B and C
- (4) B and D

- 25 Three different springs, X, Y and Z, have the same length. When three identical blocks are placed on the springs, the results are as shown.

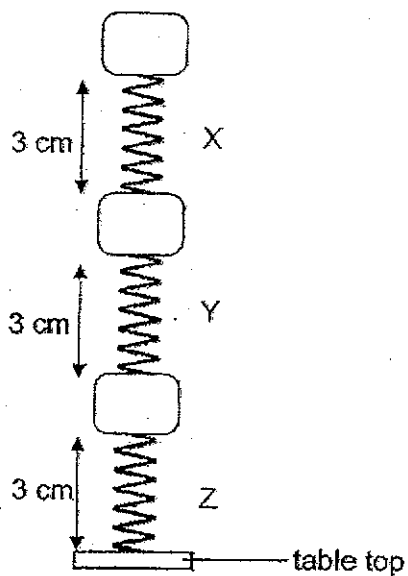

Which of the following correctly shows the relationship between the elastic spring force and the compression of springs X, Y and Z?

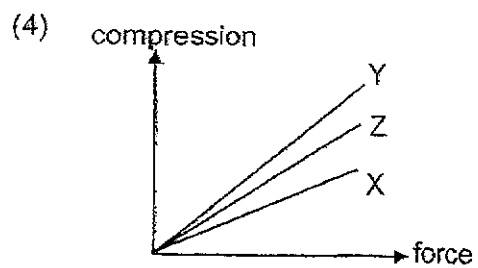
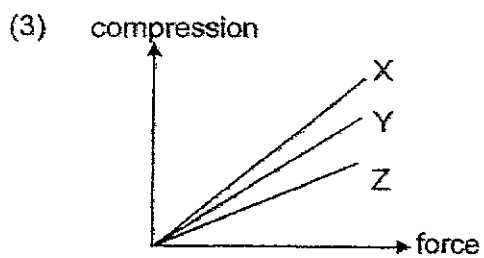
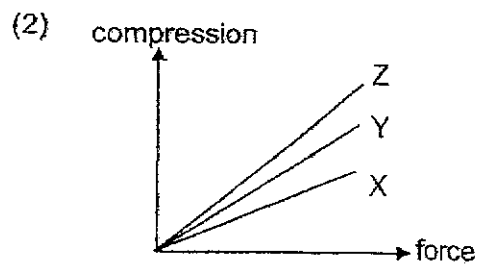
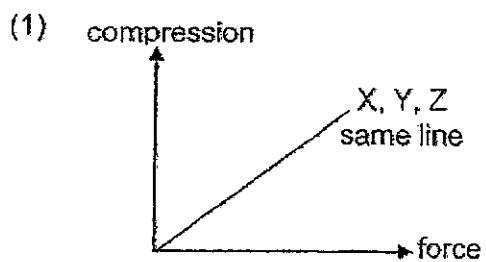

26 Ethan placed four different materials in a straight line as shown below.

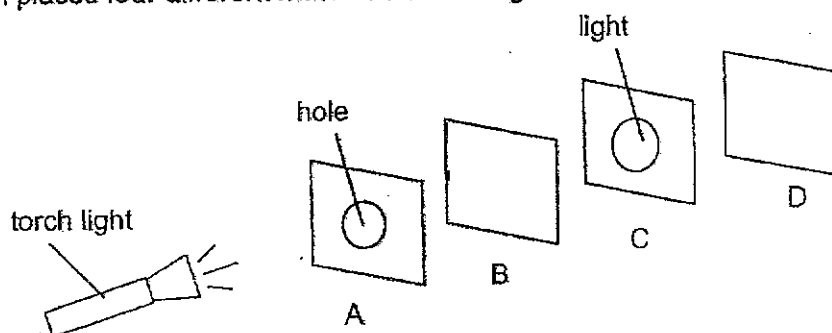

Material A has a hole cut out in the middle. Ethan switched on the torch and placed it in front of material A, a spot of light was observed on material C, but not materials B and D.

Which of the following can be concluded from his experiment?

- P Material A allows no light to pass through it.
- Q Material B allows most light to pass through it.
- R Material C allows the most light to pass through it.
- S Material D allows no light to pass through it.

- (1) P and Q only
- (2) P and R only
- (3) Q and R only
- (4) R and S only

- 27 Eric placed an ice cube each into boxes made of material S and T. After 30 minutes, he measured the volume of water collected in each box. Her results are shown in the graph below.

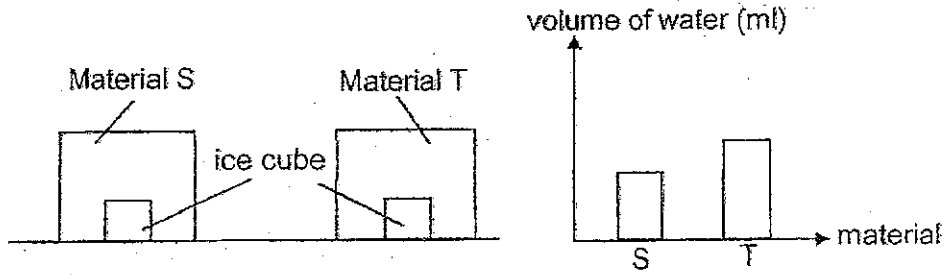

Eric wants to pack hot food and cold drinks using two containers. Which material should he choose to keep the food hot and the drinks cold for the longest period of time?

Materials for carrying		
	Hot food	Cold drinks
(1)	S	T
(2)	S	S
(3)	T	T
(4)	T	S

28

Felicia released ball A at the top of a slope, point X, as shown in the diagram below. The ball moved down the slope and past point Y.

She repeated the experiment with ball B which has more mass.

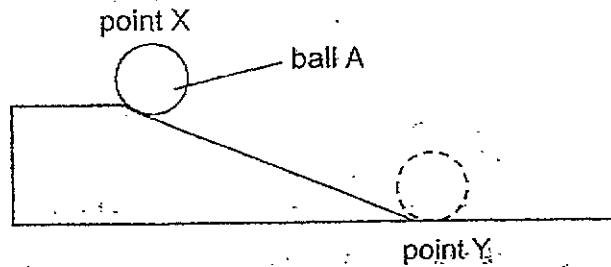

Which of the following graphs shows the changes in the amount of potential energy for balls A and B at positions X and Y?

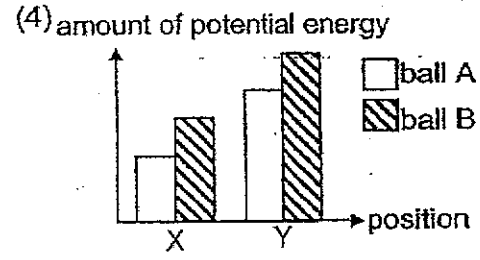
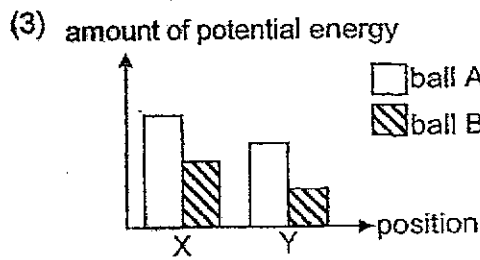
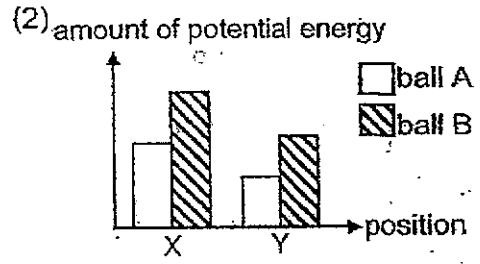
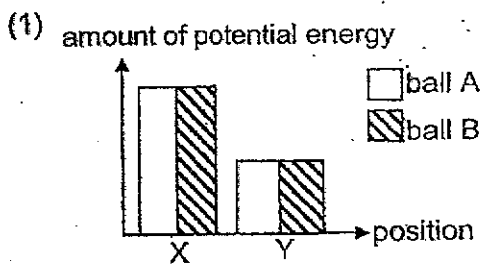



RED SWASTIKA SCHOOL

SCIENCE 2024 PRELIMINARY EXAMINATION PRIMARY 6

Name : _____ ()

Class : Primary 6/ _____

Date : 20 August 2024

BOOKLET B

12 Questions
44 Marks

In this booklet, you should have the following:

- Page 23 to Page 38
- Questions 29 to 40

MARKS

	OBTAINED	POSSIBLE
BOOKLET A		56
BOOKLET B		44
TOTAL		100

Parent's Signature : _____

Answer all the questions in the spaces provided.

- 29 Bees are commonly found near flowering plants. They help flowering plants reproduce in a process where substance G is transferred from an anther to a stigma of a flower.

- (a) Name this process and substance G. (1m)

Process: _____

Substance G: _____

Tony observed two flowers, H and J, and recorded his observations in the table below.

Flower	H	J
Colour of petal	Bright	Dull
Size of petal	Larger	Smaller
Stigma and anther	Stigma and anther are within petal	Stigma and anther are hanging outside petal

- (b) Based on Tony's observation, which flower will have more bees visiting it? Explain your answer. (2m)

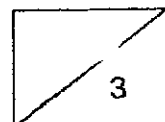

- 30 The picture below shows a polar bear.

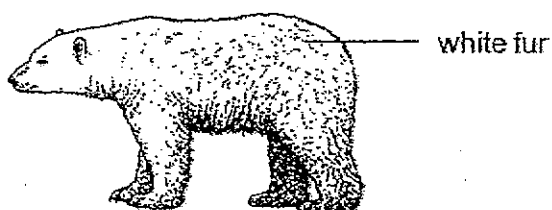

Polar bears have white fur and are found in the Arctic region. They swim in the sea to look for food. After some time, they need to get out of the water to breathe and rest on the ice before entering the water again.

- (a) Give a reason why polar bears cannot breathe under water. (1m)

- (b) State why polar bears are characterised as mammals. (1m)

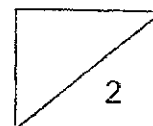

Inuka, a polar bear in Singapore Zoo, was found to have green fur instead of the usual white fur that polar bears have. Scientists have concluded that organism A grows on the fur of polar bears to make them appear green.

The graph below shows the number of organism A at different temperatures.

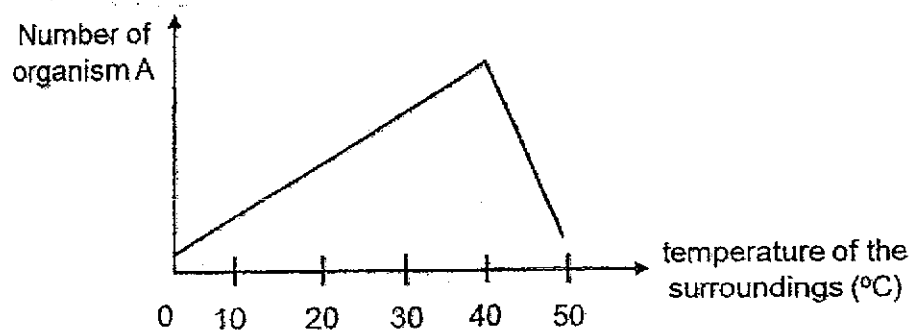

- (c) Based on the graph, describe the relationship between the temperature of the surroundings and the number of organism A. (1m)

The table below shows the average temperature of the surroundings in the Arctic region and Singapore.

Country	Average temperature of the surroundings (°C)
Arctic region	2
Singapore	36

- (d) According to the table above, explain why Inuka's fur is green (1m)

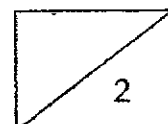

31 The air around us is made up of different types of gases.

- (a) State the part of the plant which takes in oxygen and gives out carbon dioxide. (1m)

David has a potted plant as shown below.

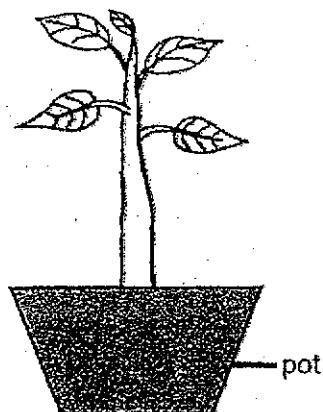

- (b) What is the plant transport system made up of? (1m)

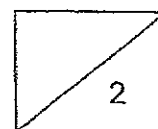

David then removed the outer ring of the stem between positions X and Y of a plant as shown in the diagram below. The food-carrying tube was removed.

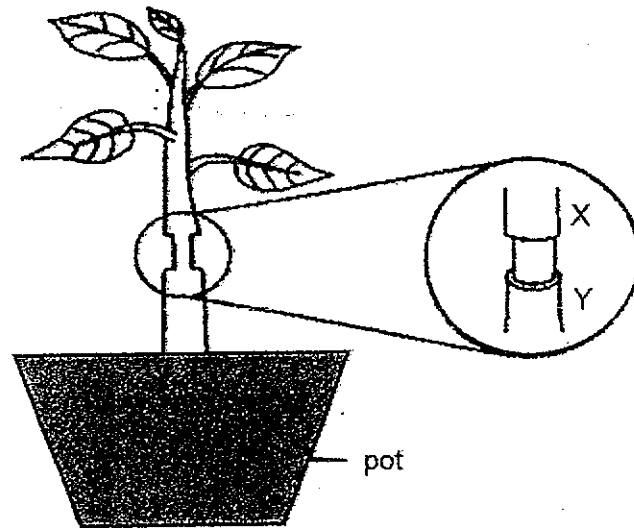

After a few weeks, he noticed that the stem at position X looked swollen as shown in the diagram below.

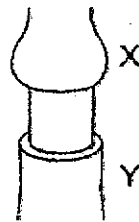

(c) Explain why the swelling occurred at position X of the stem. (2m)

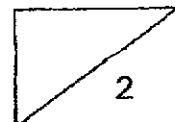

32 Animal B cannot move from place to place on its own. It stays in its hard shell while resting. Animal B extends itself out when feeding as seen in the diagram below.

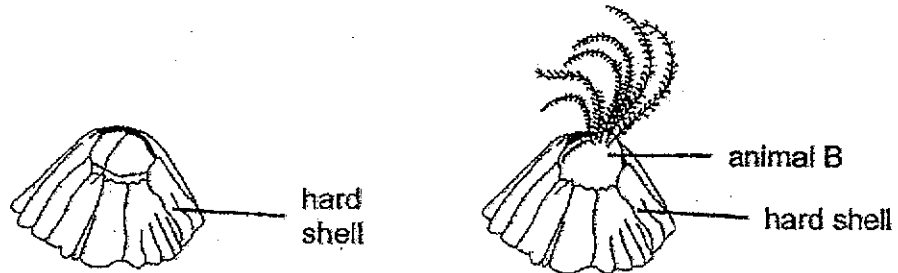

(a) How does animal B protect itself from predators? (2m)

The diagram below shows animal B attaching itself onto a whale. Animal B gets carried to other places without using much energy.

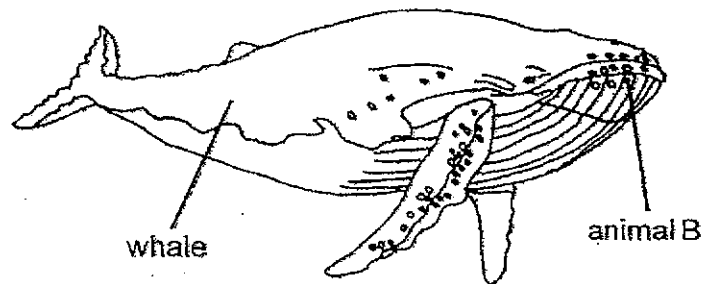

(b) How does attaching itself to a whale benefit animal B? Explain your answer. (1m)

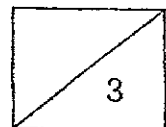

Despite its large size, a whale is able to move quickly in the water.

Being mammals, whales have to rise to the surface of the ocean to take in oxygen.

Due to human activities, the number of ships that cross the ocean has significantly increased.

- (c) Name a structural adaptation of a whale which allows it to move quickly in the water. (1m)

- (d) Suggest how the increase in the number of ships on the ocean affects the survival of whales. (1m)

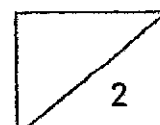

- 33 The food web below shows the relationship among the organisms, L, M, N and O, that live in the same community.

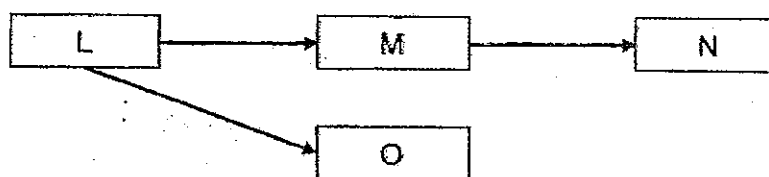

- (a) Suggest one benefit that organism L provides directly to organism N. (1m)

Karen introduced organism P into the habitat. Organism P feeds on organism M and N.

- (b) Based on the information above, will the population size of organism O increase or decrease? Give a reason for your answer. (2m)

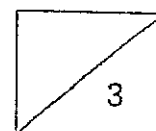

34 Cadence placed the same amount of pond water which contained tiny organisms into two identical glass containers, L and M. She painted container M black as shown in the diagram below.

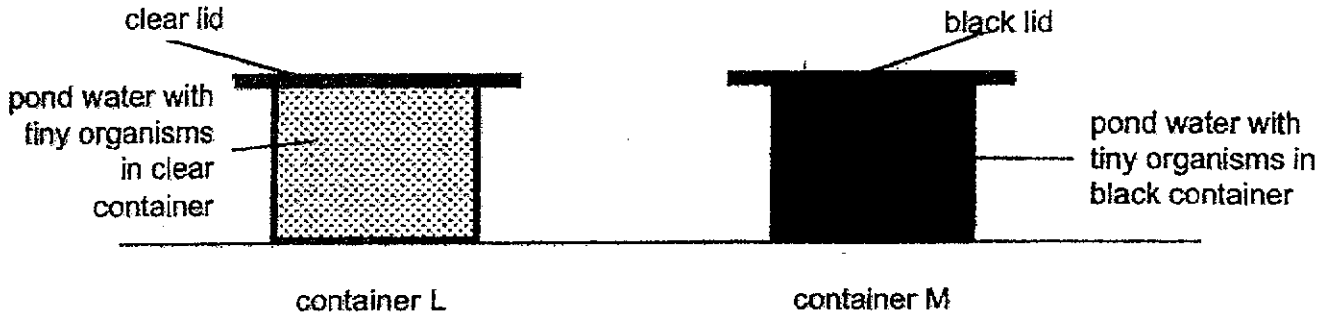

She placed both containers at the same place under bright light. She measured the amount of oxygen in each container daily. Her results are shown in the graph below.

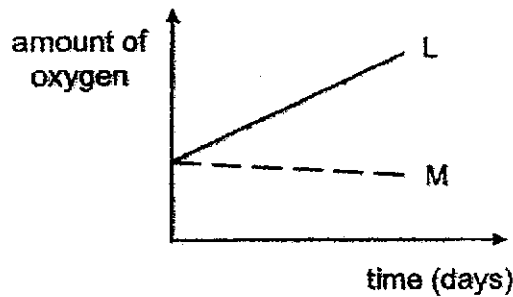

(a) Describe the change in the amount of oxygen in container M. Explain this change. (1m)

(b) Cadence concluded that the cells of the tiny organisms in the pond water contained chlorophyll.

Is her conclusion correct? Explain your answer. (2m)

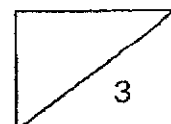

- 35 Kenny designed a system to alert bakers on the mass of the bread dough used.

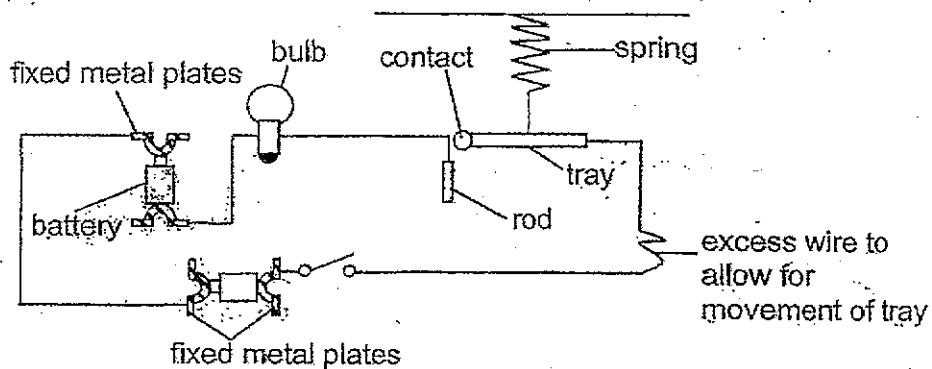

The bread dough is placed on the tray and the bulb will light up if it is within a mass of 5 to 8 units.

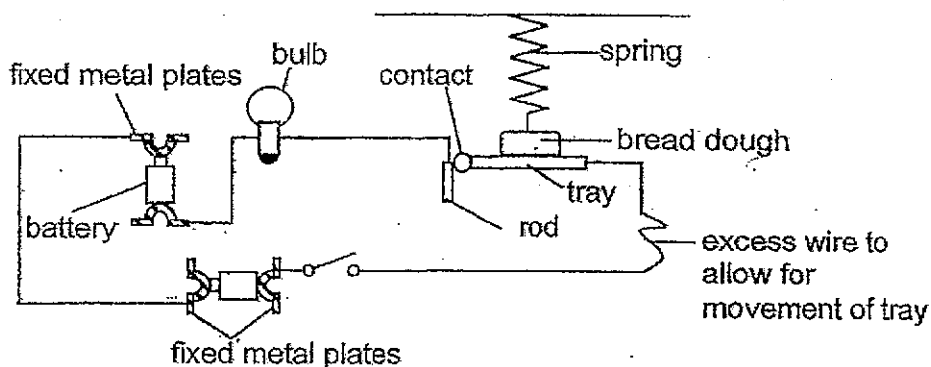

- (a) What type of material should be used for the tray so that the system can work? Explain your answer. (1m)

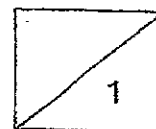

- (b) When he closed the switch, the bulb did not light up even though the mass of the bread dough was 6 units. Complete the circuit below to correct his mistake(s). (2m)

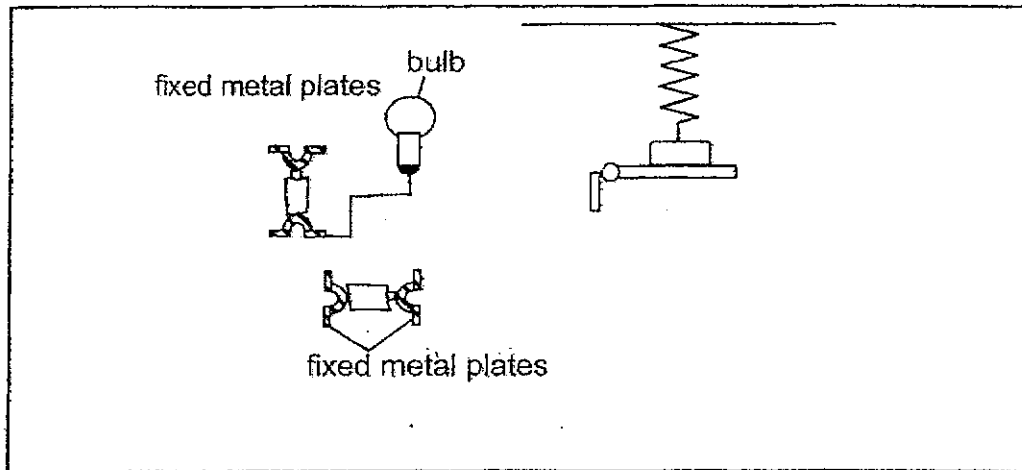

- (c) Explain why the bulb will light up when the switch is closed and a piece of bread dough with mass 6 units is placed on the tray. (1m)

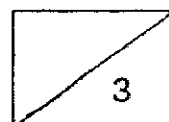

- 36 Yvette took out a large packet of frozen french fries from the freezer and left them on her kitchen table. She observed some white mist in the air around the packet of french fries after some time.

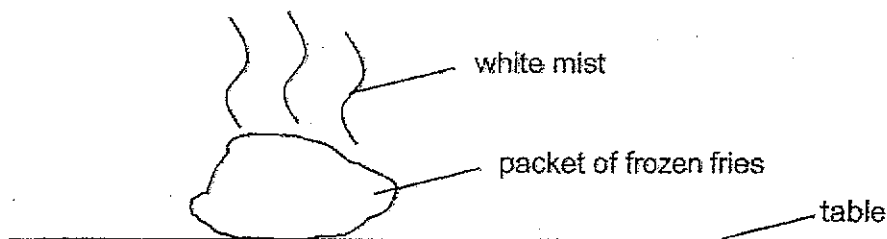

- (a) Explain how the white mist was formed. (2m)

- (b) The white mist disappears after a while. Explain why. (1m)

- (c) Yvette wanted to pack the french fries into containers. Describe one way to find the volume inside the container. (1m)

- (d) The volume of the container is 100 cm^3 . Yvette was then given some lego blocks. Each lego block has a volume of 5 cm^3 .

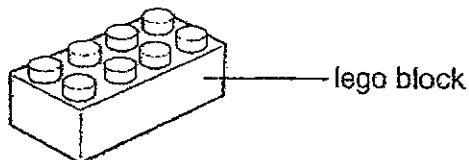

Explain, using properties of matter, why Yvette cannot put all 20 pieces of lego blocks into the container. (1m)

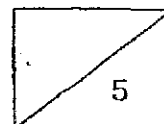

37. Muthu and Arthur wanted to investigate how the mass of a toy car affects the distance moved by it. They released a toy car from a slope at the same point and measured the distance moved by the car on the flat ground. The length of the car is 4 cm.

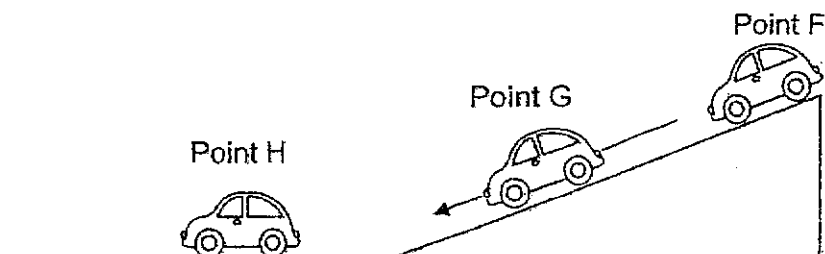

They repeated this experiment using the same slope and a toy car of similar size. Their results are shown in the table below.

	Muthu	Arthur
Distance moved by car (cm)	5	9

- (a) Given that there was no reading error, explain why Muthu and Arthur obtained different results for the distance moved by the car. (1m)

- (b) The bar graph shows the amount of gravitational force acting on the toy car at point G. Complete the graphs for the amount of gravitational force acting on the toy car at points F and H. (1m)

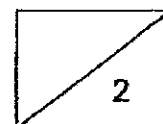
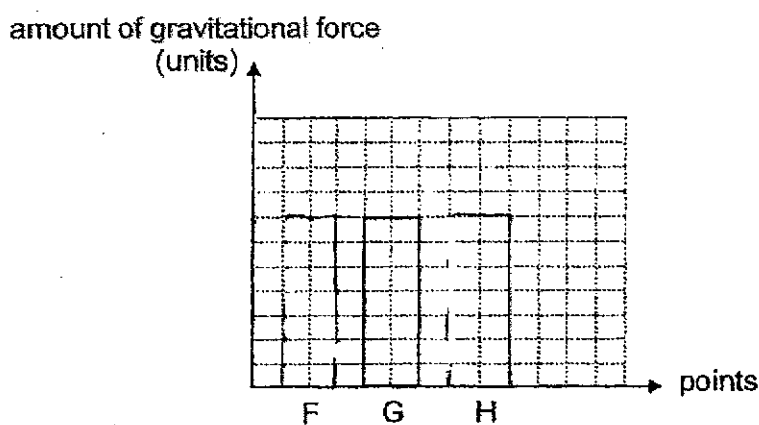

- 38 Leela set up an experiment as shown below. She observed that the rod is balanced in her experiment.

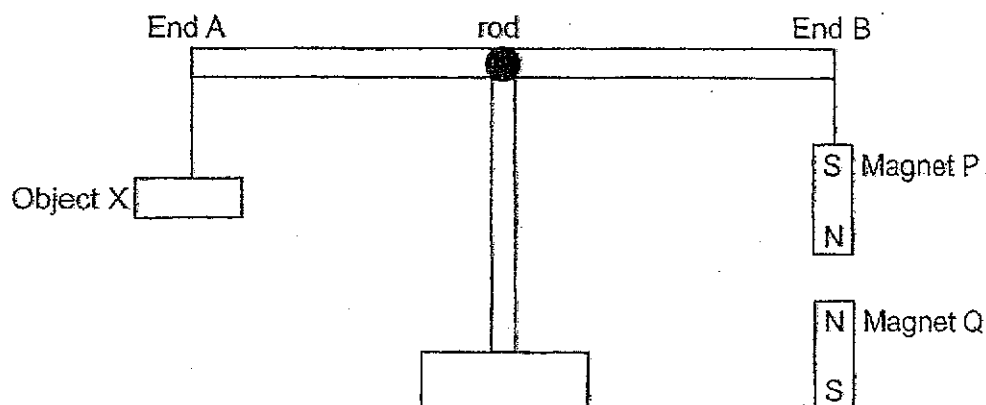

- (a) What is the property of the magnets that caused the rod to be balanced? (1m)

- (b) Compare the masses of object X and magnet P. (1m)

- (c) Leela replaced magnet P with an iron rod of the same mass. Describe and explain what happens to the rod. (1m)

- (d) State another material that will cause the same effect as the iron rod. (1m)

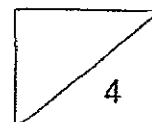

- 39 Ahmad set up an experiment to investigate how angle x , the angle at which a metal ball is released, affects the time taken for one complete swing.

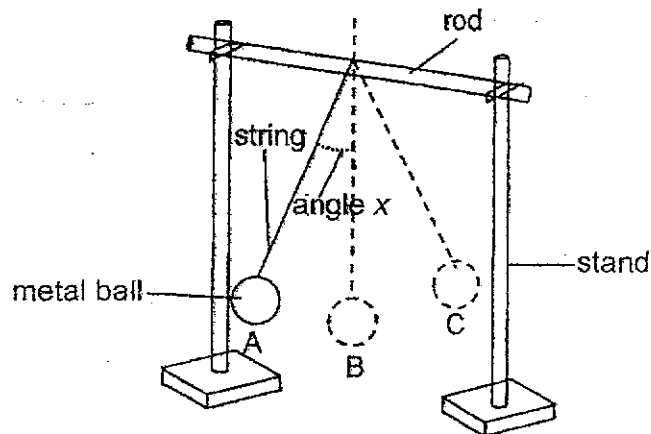

He released the metal ball gently at A. There was no wind. The metal ball made one complete swing as it moved from A to C and back to A. His results are shown below.

angle x ($^{\circ}$)	time for ten complete swings (s)
10	14.2
15	13.9
20	14.1
25	13.7

- (a) Based on his results above, how does the angle x affect the time taken for one complete swing? (1m)
-
- (b) Explain why the metal ball was unable to reach the same position after swinging from A to C and back to A. (1m)
-
- (c) Suggest one improvement to the experiment to obtain more accurate results. (1m)
-

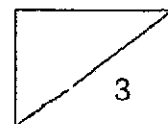

- 40 Sylvia boiled some water in a pot on a stove. She wanted to cook some fishballs that she just took out from the refrigerator. When the water had boiled, she added the fishballs into the pot. She measured the temperature of the water for 60 minutes and recorded her results below.

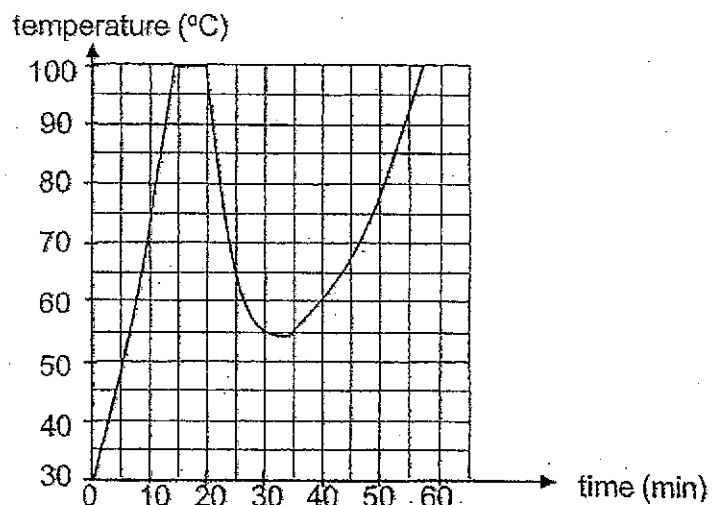

- (a) State what is temperature. (1m)
-
- (b) State the time Sylvia added the fishballs into her pot. (1m)
-

After the fishballs were cooked, Sylvia scooped 3 fishballs and some soup from the pot into two identical bowls, G and H, as shown below.

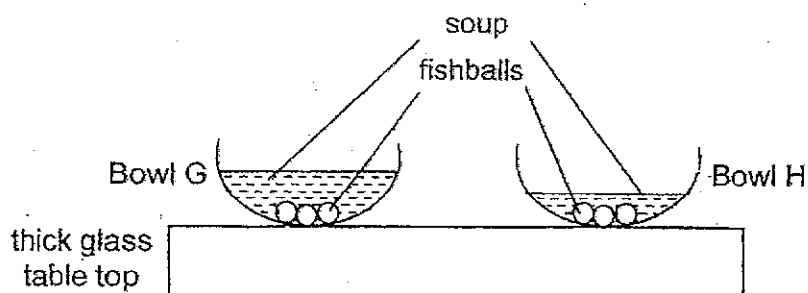

- (c) In which bowl, G or H, would the fishball cool down faster? Why? (1m)
-
-
- (d) The table top cracked after some time. Explain why. (1m)
-
-

RED SWASTIKA SCHOOL
P6 SCIENCE Prelim 2024
Answer Key

Section A: Multiple Choice Questions (MCQ) (56 marks)

28 Questions, 2 marks each

1. (2)	6. (2)	11. (3)	16. (3)	21. (1)	26. (1)
2. (4)	7. (2)	12. (2)	17. (1)	22. (1)	27. (2)
3. (4)	8. (1)	13. (2)	18. (3)	23. (3)	28. (2)
4. (1)	9. (1)	14. (3)	19. (2)	24. (4)	
5. (3)	10. (4)	15. (2)	20. (4)	25. (3)	

Qn.	Answer	Mark
29a	Process: <u>Pollination</u> Substance G: <u>Pollen grain/ pollen</u>	1m
29b	Flower H. Flower H is <u>brighter in colour</u> and <u>has larger petals</u> . Thus, bees will be <u>more attracted to flower H</u> .	2m
30a	Polar bears <u>have lungs/do not have gills</u> .	1m
30b	Polar bears <u>have hair or fur</u> (as their outer covering). OR Polar bears <u>provide milk to their young</u> . OR Polar bears <u>give birth to their young alive</u> .	1m
30c	As the temperature of the surroundings <u>increase from 0 – 40°C</u> , the number of organism A increases. As the temperature of the surroundings <u>increase from 40 – 50°C</u> , the number of organism A decreases.	1m
30d	The average temperature of Singapore is <u>higher than in the Arctic region</u> . Thus, <u>the number of organism A growing on Inuka's fur is higher</u>	1m

31a	Tiny openings in the leaves/ stomata/ leaves	1m
31b	Water-carrying tubes and food-carrying tubes	1m
31c	Since the food-carrying tubes were removed, <u>food made in the leaves cannot be transported to the roots/ accumulated at X/ cannot be transported to Y.</u>	2m
32a	Animal B can <u>hide in its hard shell to prevent predators from spotting/ seeing and eating it.</u>	2m
32b	Animal B can move to a place which is <u>richer in food.</u>	1m
32c	<u>Developed fins/ Streamlined body shape</u>	1m
32d	The whales might <u>hit the ships (when they surface) and get injured.</u>	1m
33a	Organism L can <u>photosynthesise and provide oxygen</u> for organism N.	1m
33b	Population size of O will increase. A <u>decrease in population of M will lead to an increase in population of L</u> as there is <u>less M eating L</u> . Thus, there will be <u>more of L for O to eat</u> . With more food, population size of O will increase.	2m
34a	The amount of oxygen <u>decreased in container M</u> . The tiny organisms (respire) and <u>take in the oxygen in the water.</u>	1m
34b	Yes, her conclusion is correct. The tiny organisms could <u>trap / receive light and make their own food/ photosynthesise to produce oxygen</u> . Thus, the amount of oxygen increased.	2m

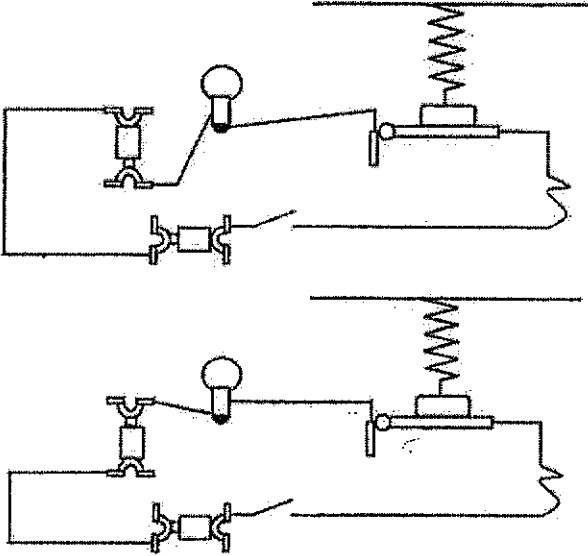
35a	<u>Metal</u> . Metal is <u>an electrical conductor/ electric current can flow through</u> .	1m
35b	<p>Key concept:</p> <ul style="list-style-type: none"> • Batteries need to be connected from the positive to negative terminal • Bulbs need to be connected to the metal tip and metal casing 	2m
35c	<u>A closed circuit</u> is formed and <u>electricity can flow through the circuit</u> .	1m
36a	<u>Frozen french fries cooled the surrounding air</u> . <u>Warmer water vapour in the surrounding air</u> came into contact with the cooler air. <u>The warmer water vapour lost heat and condensed</u> into tiny water droplets in the air.	
36b	The water droplets <u>gained heat from the surroundings</u> and <u>evaporated</u> .	1m
36c	Pour water into the container to <u>its brim/ full</u> . Measure the volume of water <u>using a measuring cylinder</u> .	1m
36d	The lego blocks had a <u>definite shape</u> and was unable to fit into the container <u>without leaving air spaces/gaps in between them</u> .	1m
37a	They measured the distance from the bottom of the slope to different points of the car.	1m

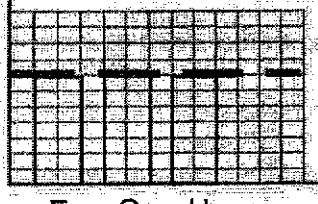
37b	<p>Key concept: Amount of gravitational force remains the same at different positions</p> <p>amount of gravitational force (units)</p> <p>Same height</p>  <p>points</p> <p>F G H</p>	1m
38a	Magnets <u>repel each other</u> when their <u>like poles</u> are facing each other.	1m
38b	Magnet P has <u>more mass / is heavier than object X.</u> OR Object X has <u>less mass / is lighter than magnet P.</u>	1m
38c	The rod will <u>tilt downwards towards end B.</u> Iron is a magnetic material and <u>will be attracted to magnet Q.</u>	1m
38d	Steel, nickel or cobalt	1m
39a	Angle x does not affect the time taken for one complete swing.	1m
39b	Some of the energy is <u>converted to heat and sound</u> and there was <u>not enough energy converted to potential energy.</u>	1m
39c	Take <u>more readings</u> and <u>calculate the average</u> for each value of angle x .	1m
40a	Temperature is <u>a measure/measurement of how hot or cold an object is.</u>	1m
40b	20 minutes	1m
40c	Bowl H. There was <u>less soup</u> in Bowl H and hence, there was <u>less heat.</u>	1m
40d	The top of the glass <u>gained heat faster</u> from the bottom of the bowl. There was <u>uneven expansion/ the top expanded faster than the bottom</u> in the glass.	1m