



2024 PRIMARY 6 PRELIMINARY EXAMINATION

Name : _____ ()

Date: 21 August 2024

Class : Primary 6 ()

Time: 8.00 a.m. - 9.45 a.m.

Duration: 1 hour 45 minutes

SCIENCE BOOKLET A

INSTRUCTIONS TO CANDIDATES

1. Write your name, class and register number.
2. Do not turn over this page until you are told to do so.
3. Follow all instructions carefully.
4. Answer all questions.
5. Shade your answers on the Optical Answer Sheet (OAS) provided.

Booklet A (28 x 2 marks)

For each question from 1 to 28, four options are given. One of them is the correct answer. Make your choice (1, 2, 3 or 4) and shade your answer on the Optical Answer Sheet.

(56 marks)

1. A plant was placed inside a box with a hole. It was placed in a well-lit room.

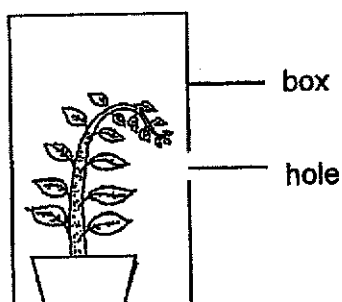

It was observed that the stem of the plant grew towards the hole.

This was because _____.

- (1) there was no air in the box
- (2) there was more light outside the box
- (3) gravity was pulling the plant downwards
- (4) there was no space for the plant to grow upwards

2. Study the classification chart on organisms.

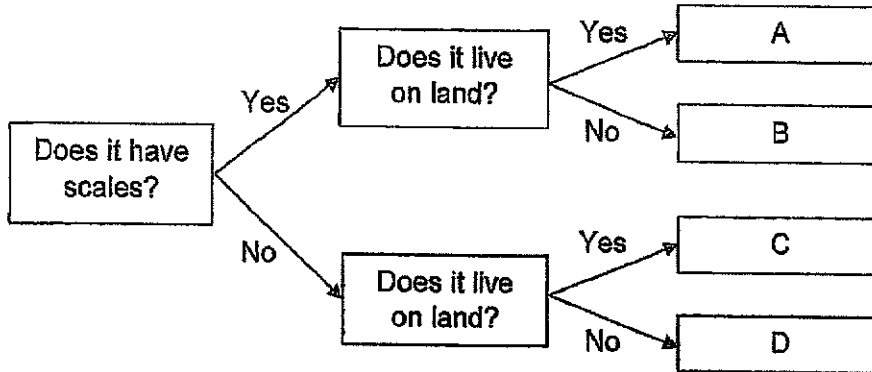

Which of the following is possible?

- (1) A is a fish.
- (2) B is a mosquito.
- (3) B and D are reptiles.
- (4) C and D are mammals.

3. Study the table below. A tick (✓) indicates the presence of the part of a cell.

	Cell X	Cell Y	Cell Z
cell wall			
cell membrane		✓	✓
chloroplasts			

Where are the cells most likely to be found?

	Cell X	Cell Y	Cell Z
(1)	cheek	root	leaf
(2)	leaf	cheek	root
(3)	leaf	root	cheek
(4)	root	leaf	cheek

4. Two parts of a flower in a plant were removed before pollination took place.

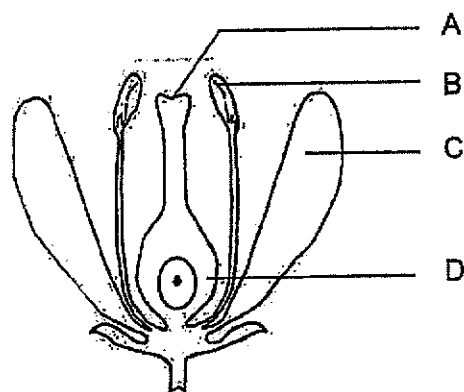

Which of the following is definitely correct?

	Parts removed	Development of fruit
(1)	A and B	yes
(2)	A and C	yes
(3)	B and C	no
(4)	B and D	no

5. The plant was wrapped and tied with a black plastic bag as shown.

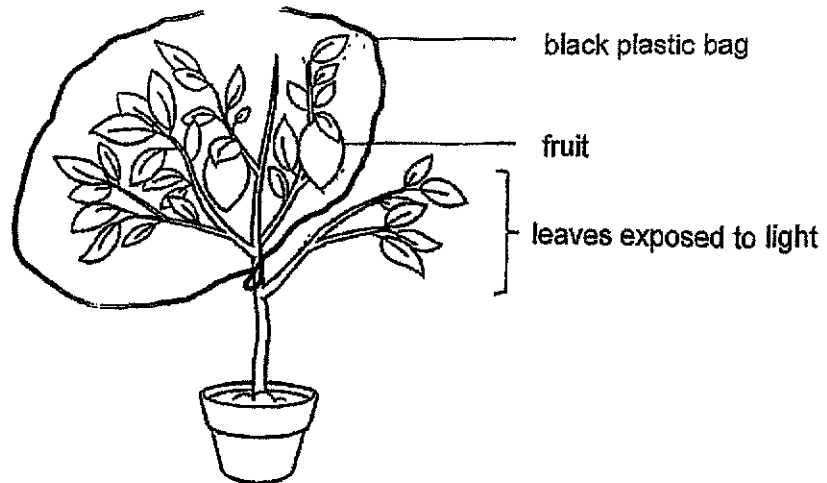

The food produced by the exposed leaves was transported _____.

- (1) only upwards by the food-carrying tubes
 - (2) only upwards by the water-carrying tubes
 - (3) upwards and downwards by the food-carrying tubes
 - (4) upwards and downwards by the water-carrying tubes
6. Which of the following is true about the difference between inhaled air and exhaled air of a person?

	Inhaled air	Exhaled air
(1)	more carbon dioxide	less carbon dioxide
(2)	more nitrogen	less nitrogen
(3)	less oxygen	more oxygen
(4)	less water vapour	more water vapour

7. The populations of organisms X, Y and Z are shown in the graph below. One of them is a food producer.

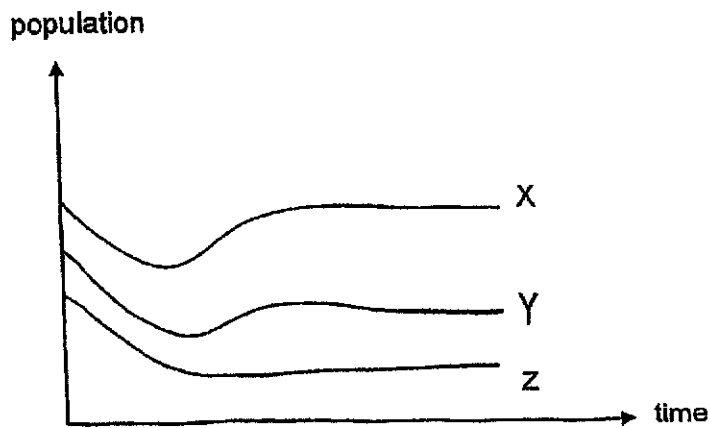

Based on the information above, which of the following shows the correct relationship between the organisms?

- (1) X is a prey of Y.
 - (2) X is a prey of Z.
 - (3) Y is a predator of Z.
 - (4) Z is a predator of Y.
8. What is one impact of global warming?

- (1) polar ice melts faster
- (2) increase in air pollution
- (3) global temperature rises
- (4) more carbon dioxide in the air

9. The fruits of plants A and B are shown below.



fruit from plant A



fruit from plant B

Key:

Young plant A	
Young plant B	

Which of the following shows the number of young plants at various distances from their parent plants in a garden?

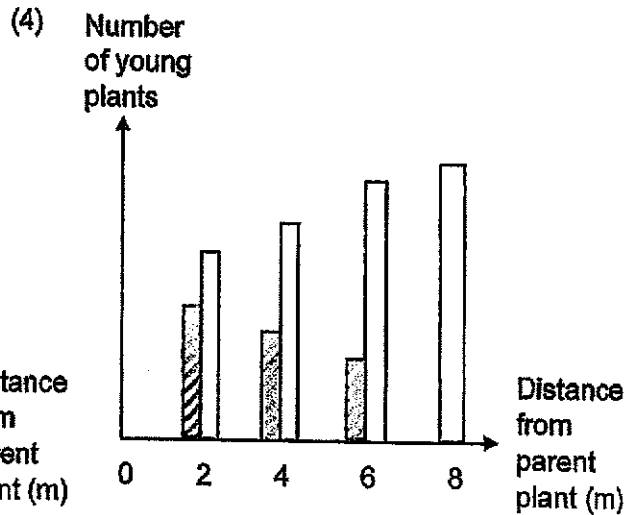
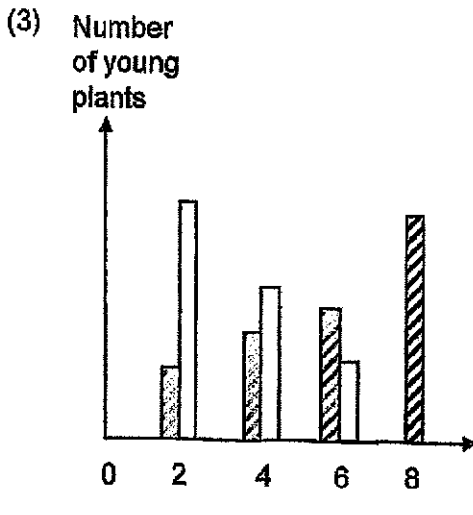
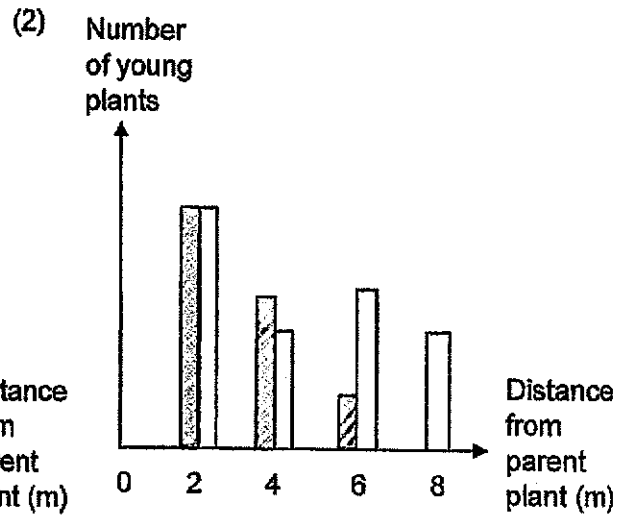
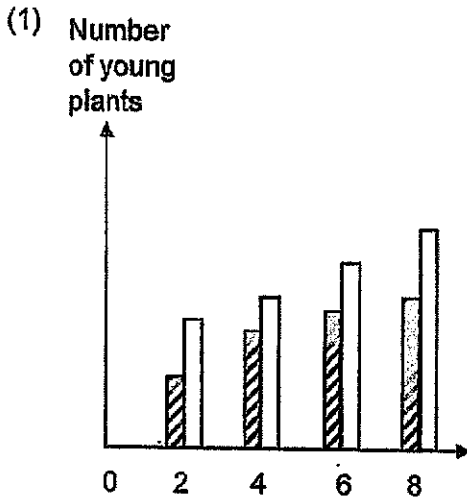

10. The diagram below shows the direction of blood flow in some parts of the human body.

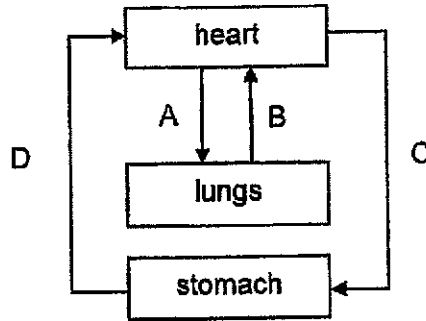

Which is correct about the blood flowing in the blood vessels?

- (1) There is less oxygen in B than in A.
 - (2) There is more oxygen in C than in A.
 - (3) There is less carbon dioxide in A than in B.
 - (4) There is more carbon dioxide in C than in D.
11. The diagram below shows a human digestive system.

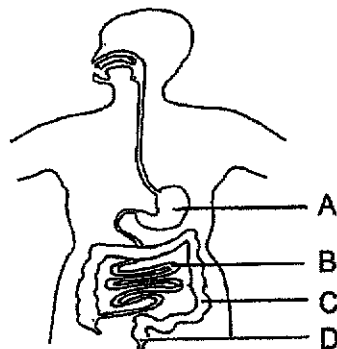

Which of the following is definitely true after a bowl of rice is eaten?

- (1) The amount of digested food increased between parts B and C.
- (2) The amount of digested food increased between parts C and D.
- (3) The amount of undigested food increased between parts A and B.
- (4) The amount of undigested food remained the same between parts C and D.

12. The diagram below shows a food web.

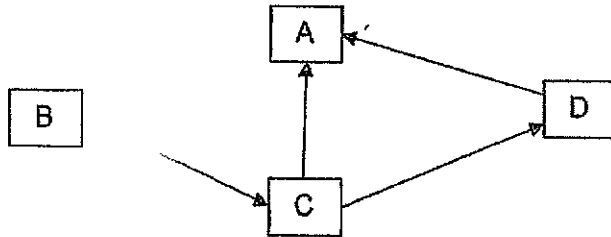

Which of the following will most likely take place when a new predator of organism D is added to the community above?

- (1) More D will feed on C.
- (2) A will feed on more C.
- (3) C will feed on more A.
- (4) Fewer D will feed on A.

13. Animal X has many adaptations that help it to survive in the desert which is hot in the day and cold in the night.

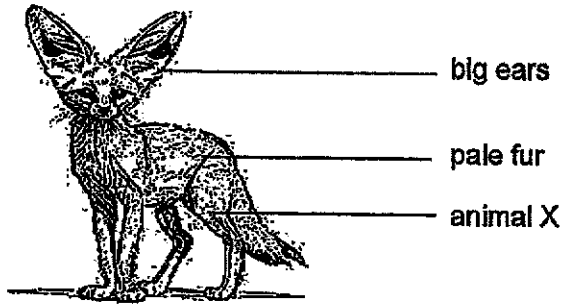

Which of the following does not correctly explain how the adaptation helps it to survive?

	Adaptation	How it helps in its survival
(1)	keen sense of smell	to find prey more easily
(2)	active at night	to avoid the heat in the day
(3)	large ears	to gain more heat to keep warm
(4)	pale fur	to blend in with its surroundings

14. Three leaves of a plant were wrapped using three different types of plastic bags of the same size. The pot of plant was then placed in a clear box with very limited air in an open field for three hours.

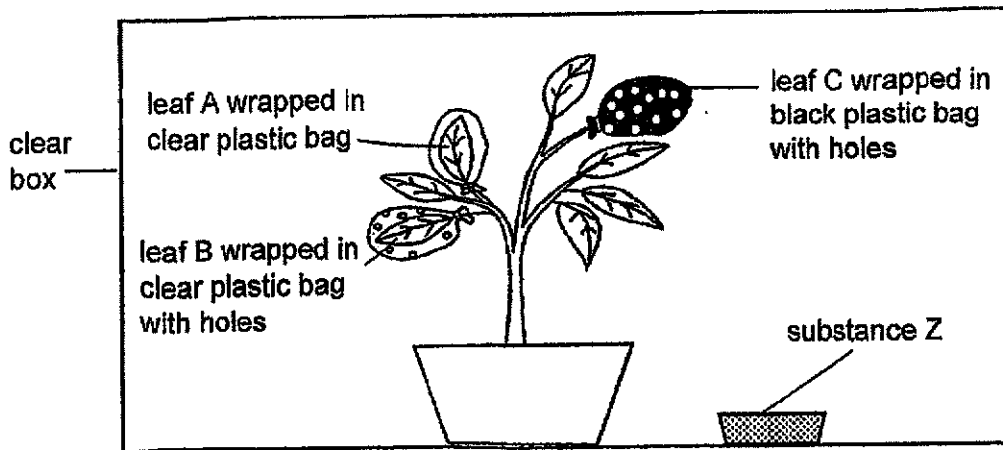

The graph below shows the amount of food made by the leaves during the three hours.

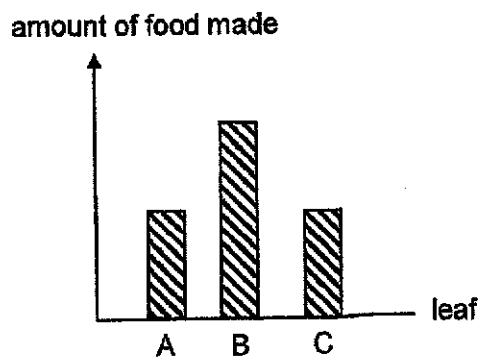

Based on the results above, what could substance Z be?

- (1) substance that absorbs oxygen
- (2) substance that produces oxygen
- (3) substance that absorbs carbon dioxide
- (4) substance that produces carbon dioxide

15. Which of the following is definitely **not** true about matter?

- (1) It has volume.
- (2) It may be compressed.
- (3) It can be a push or a pull.
- (4) It can change from a gas to a liquid.

16. Rajesh conducted an experiment to compare the magnetic strength of magnets A, B and C. The magnets were fixed on three identical ramps at different positions.

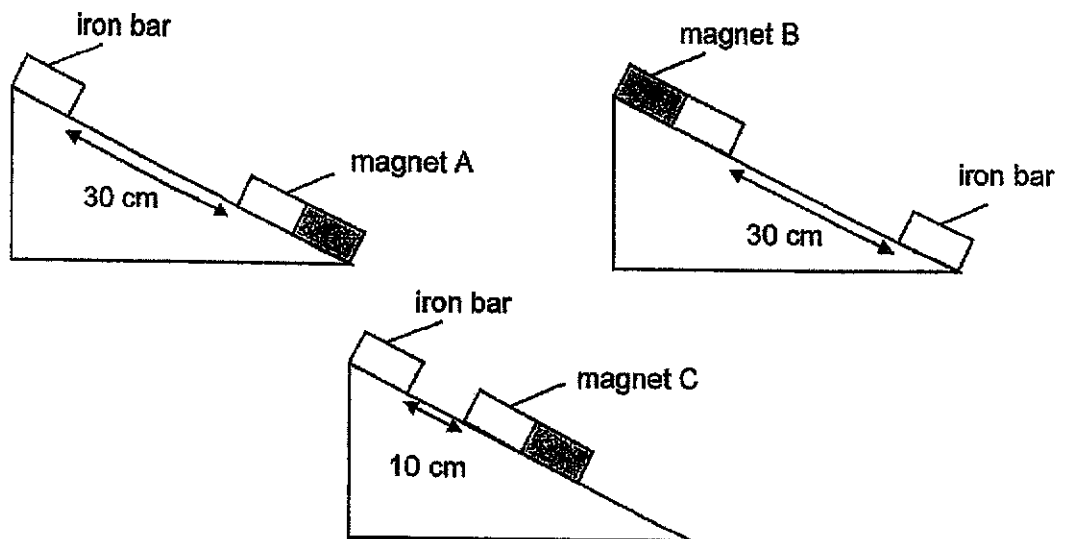

Rajesh observed that all the iron bars took the same amount of time to come into contact with the magnets.

Which of the following can be concluded about the magnetic strength of magnets A, B and C?

- (1) A is stronger than B.
- (2) C is stronger than A.
- (3) B is stronger than C.
- (4) A and B are equally strong.

17. A metal ball is released through a hole at the bottom of a wooden dish and it rolls along a metal track back and forth until it comes to a complete stop on the track.

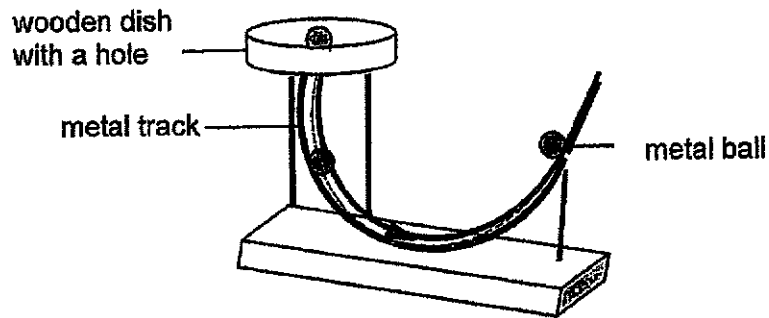

Which of the following change will cause the ball to roll on the track for a longer time before stopping?

- (1) Use a heavier track.
 - (2) Raise the height of the wooden dish.
 - (3) Lower the height of the wooden dish.
 - (4) Use a glass ball of the same mass as the metal ball instead.
18. Suling turns on the bedside lamp to read her story book at night.

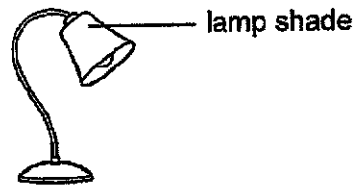

Which material is most suitable for making the lamp shade if she does not want to affect the sleep of her sister who sleeps next to her?

	Material	Property	
		conducts electricity	allows light to pass through
(1)	A	X	
(2)	B		
(3)	C		X
(4)	D	X	X

19. A solid made of three different substances, P, Q and R, is placed in a room.

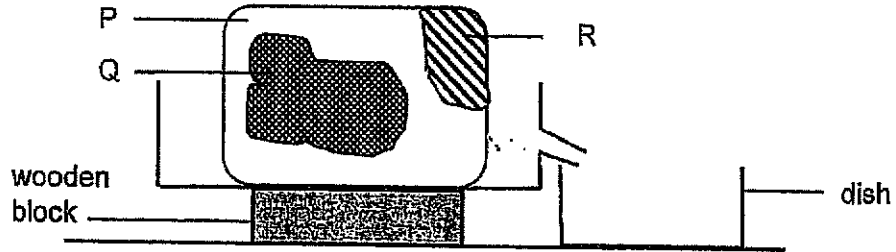

The table shows the freezing points of the three substances.

Substance	Freezing Point
P	44
Q	50
R	110

Which of the substances will be collected in the dish when the temperature of the surroundings is increased to 65°C ?

- (1) P only
- (2) R only
- (3) P and Q only
- (4) None of the above

20. A sealed container containing air and liquid X was set up for an experiment as shown below.

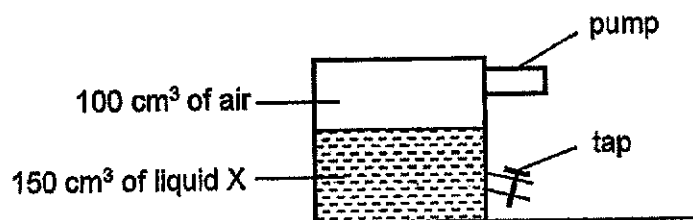

50 cm³ of liquid X was removed from the container through the tap and 20 cm³ of air was then pumped in using the pump.

Which of the following is true about the air and liquid X at the end of the experiment?

- (1) The volume of air is 150 cm³.
- (2) The capacity of the container is 220 cm³.
- (3) The mass of air is more than the mass of liquid X.
- (4) The air occupies the same amount of space in the container as liquid X.

21. A circuit is set up as shown below.

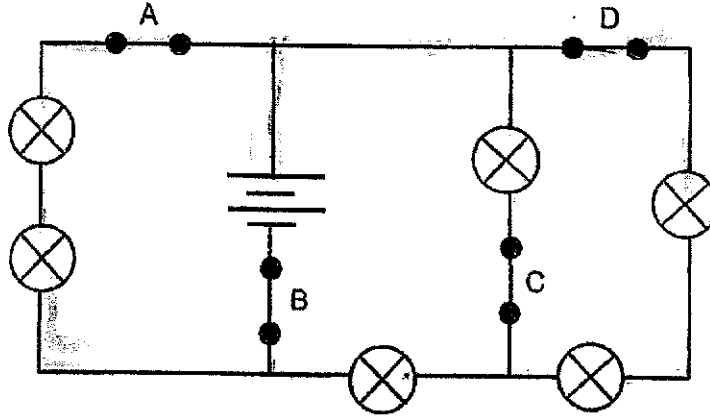

All the six bulbs light up when all the four switches are closed. When only one of the switches is opened, only some of the bulbs light up and they are of equal brightness.

Which switch is opened?

- (1) A
- (2) B
- (3) C
- (4) D

22. The diagram below shows part of a circuit.

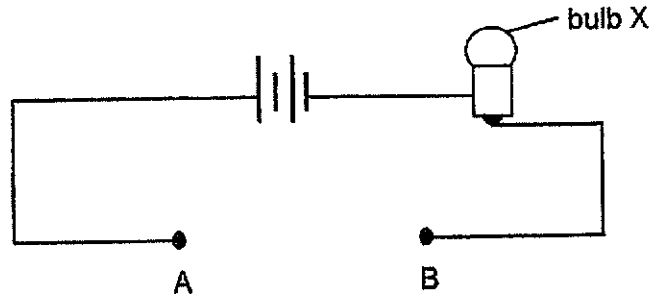

Which of the following, when fitted between points A and B, will cause bulb X to be the brightest?

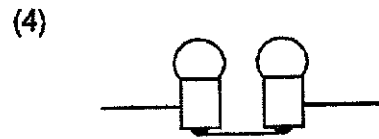
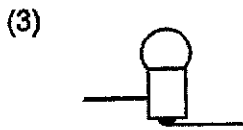
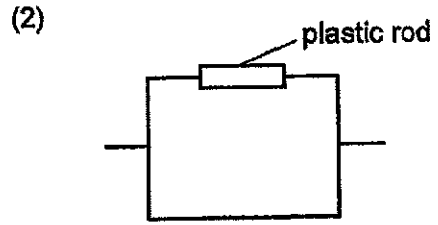
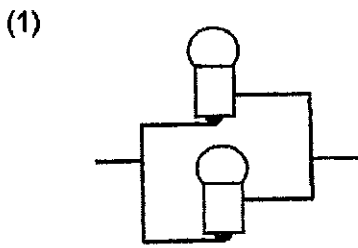

23. Four identical magnets with the same magnetic strength and two different springs, R and S, of equal original length, are used in the set-ups shown below.

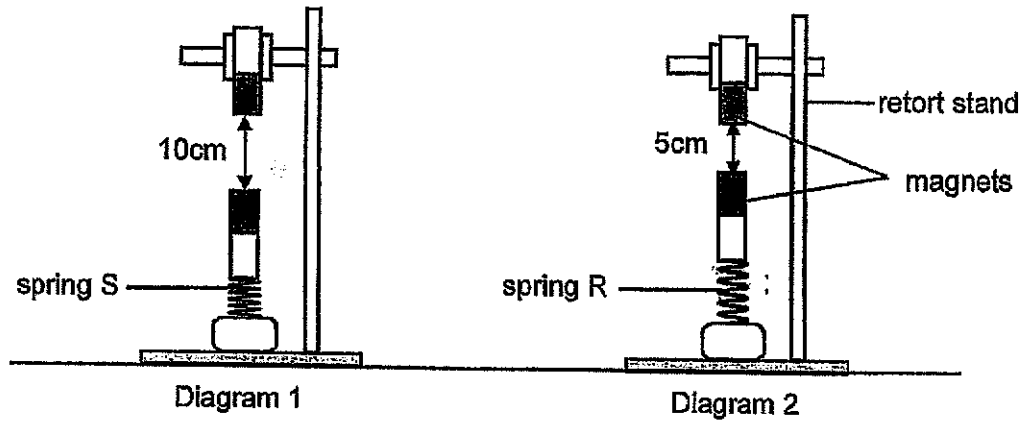

Which of the following can be concluded from the observations above?

- (1) Spring S is a stiffer spring than spring R.
 - (2) Spring R exerts a larger elastic spring force than spring S.
 - (3) The length of compression of spring S is definitely 10 cm.
 - (4) Springs R and S exert the same amount of elastic spring force.
24. Henry jumps over a hurdle as shown in the diagram below.



Diagram 1



Diagram 2

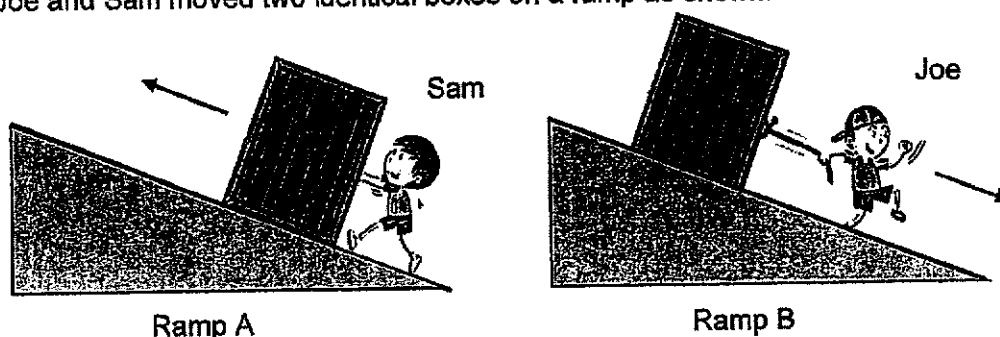

Diagram 3

Based on the diagrams above, which statement is correct?

- (1) Most gravitational force is acting on Henry at Diagram 2.
- (2) Gravitational force is acting on Henry only in Diagram 2.
- (3) Gravitational force acting on Henry is equal in all the diagrams.
- (4) More gravitational force is acting on Henry in Diagram 1 than in Diagram 3.

25. Joe and Sam moved two identical boxes on a ramp as shown.



They used the same amount of time to move the box from one end of the ramp to the other but Sam used less force to do it.

Why did Sam use less force to move the box along the ramp?

- (1) The box was moving against gravity.
 - (2) The surface of ramp A was smoother.
 - (3) Surfaces of ramps A and B were identical.
 - (4) A lubricant was applied on the surface of ramp B.
26. Four identical hot metal cubes at 100°C were placed in two beakers of water, A and B, at room temperature as shown below.

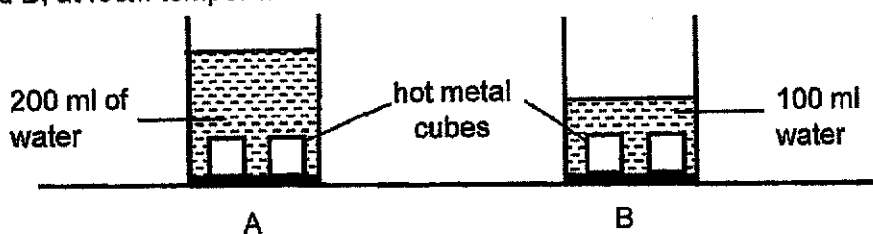

Which of the following is definitely true at the end of the 10 minutes?

- (1) Water in both beakers would be boiling.
- (2) Water in A would be colder than water in B.
- (3) Metal cubes in A would have lost less heat to the water compared to those in B.
- (4) Metal cubes in B would have gained less heat from the water compared to those in A.

27. Bala had three different materials, X, Y and Z. He cut out holes of different shapes from each of the materials as shown.

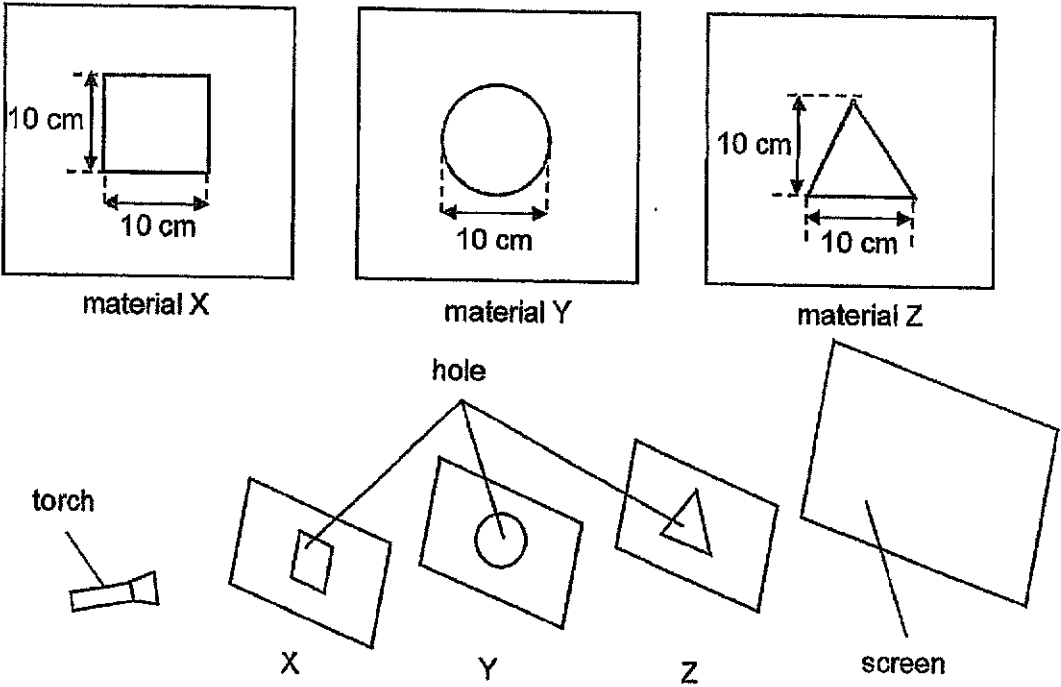

Light is shone on the materials and the shadow formed on the screen is shown below.

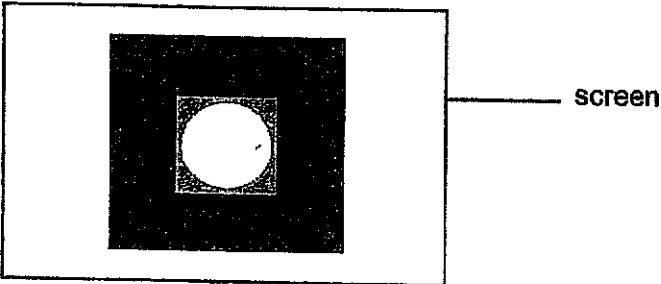

Which of the following is true about materials X, Y and Z?

- (1) X blocks less light than Z.
- (2) Y blocks more light than X.
- (3) Y does not allow light to pass through.
- (4) X allows less light to pass through than Y.

28. Meimei made a simple set-up of a hydro-electric power station. The water turns the blades in the turbine so that electricity is produced by the generator to light up the bulb.

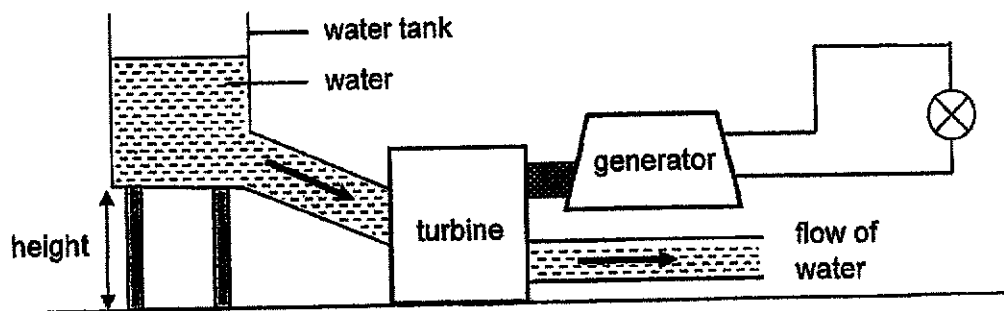

Meimei wanted to find out if the speed of the blades turning in the turbine affects the brightness of the bulb. Which variable should she change in this experiment?

- (1) type of light bulb
- (2) brightness of the bulb
- (3) material of the water tank
- (4) height of water tank above the ground

End of Booklet A



2024 PRIMARY 6 PRELIMINARY EXAMINATION

Name : _____ ()

Date: 21 August 2024

Class : Primary 6 ()

Time: 8.00 a.m. – 9.45 a.m.

Parent's Signature : _____

Duration: 1 hour 45 minutes

SCIENCE

BOOKLET B

INSTRUCTIONS TO CANDIDATES

1. Write your name, class and register number.
2. Do not turn over this page until you are told to do so.
3. Follow all instructions carefully.
4. Answer all questions.
5. Use a dark blue or black ballpoint pen to write your answers in the space provided for each question.
6. Do not use correction fluid/tape or highlighters.

Booklet A	56
Booklet B	44
Total	100

Booklet B (44 marks)

For questions 29 to 41, write your answers clearly in this booklet.

The number of marks available is shown in brackets [] at the end of each question or part question.

(44 marks)

- 29 Jack conducted an experiment using the set-ups, A and B, as shown below. He observed the grasshoppers over a few days.

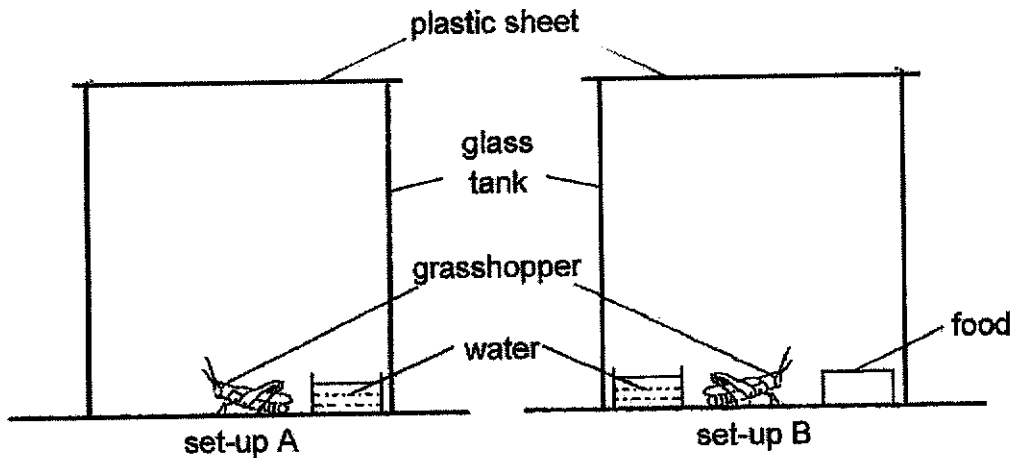

- (a) His teacher suggested making holes on both the plastic sheets. Explain why. [1]

- (b) After a few days, the grasshopper in set-up A died. What could he conclude from the experiment? [1]

- (c) Explain the purpose of set-up A. [1]

Score	3
-------	---

30 The following diagram shows the cross section of flower H.

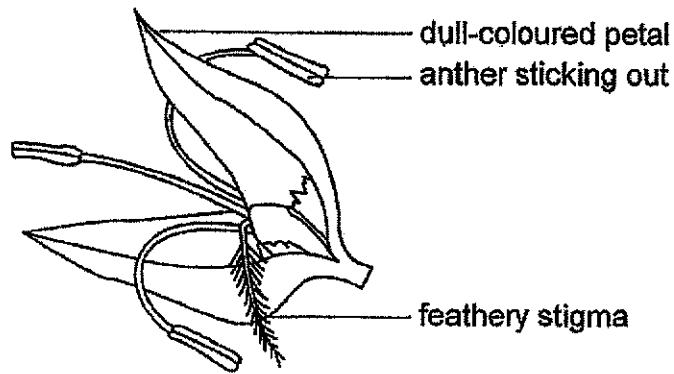

(a) Based on the diagram above, state the method of pollination of flower H. [1]

(b) Give a structural adaptation of flower H that supports your answer in part (a) and explain how that would help the flower to be pollinated. [1]

(c) A farmer planted many flower H in an enclosed greenhouse as shown below to protect flower H from the extreme cold environment.

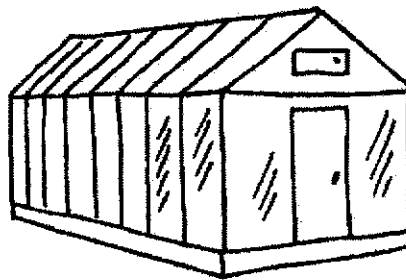

The flowers did not develop into any fruits. What could he do to get the flowers to develop into fruits? [1]

Score	3
-------	---

31 The diagram shows a human body system.

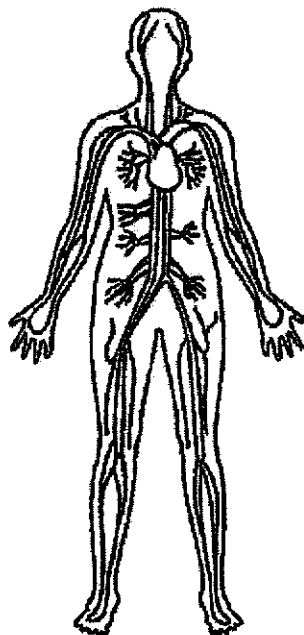

(a) Name two parts of this system.

[1]

(b) State the function of this system.

[1]

Score	2
-------	---

(c) Adam is born with a hole in his heart as shown in the diagram below.

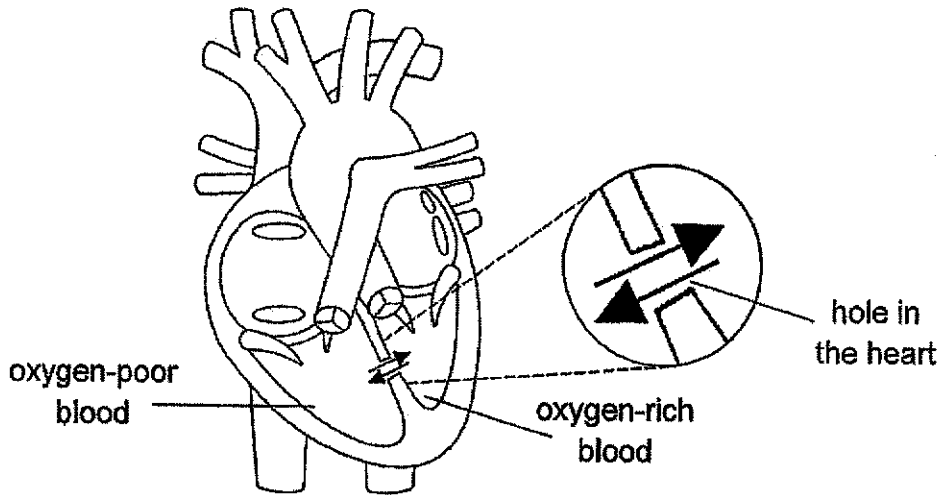

This hole causes the oxygen-poor blood to mix with the oxygen-rich blood in his heart. As a result, there is less oxygen in the blood flowing from the heart to all parts of the body.

His breathing rate and heart rate at rest tends to be higher than a healthy person. Explain why both rates are higher. [2]

Score	2
-------	---

32 Susan wanted to find out if the presence of grass affects the amount of soil particles washed into water. She used two set-ups, X and Y, as shown below. An equal volume of water was poured over the two trays which had many tiny holes at the bottom. Water passed through and was collected in the beakers.

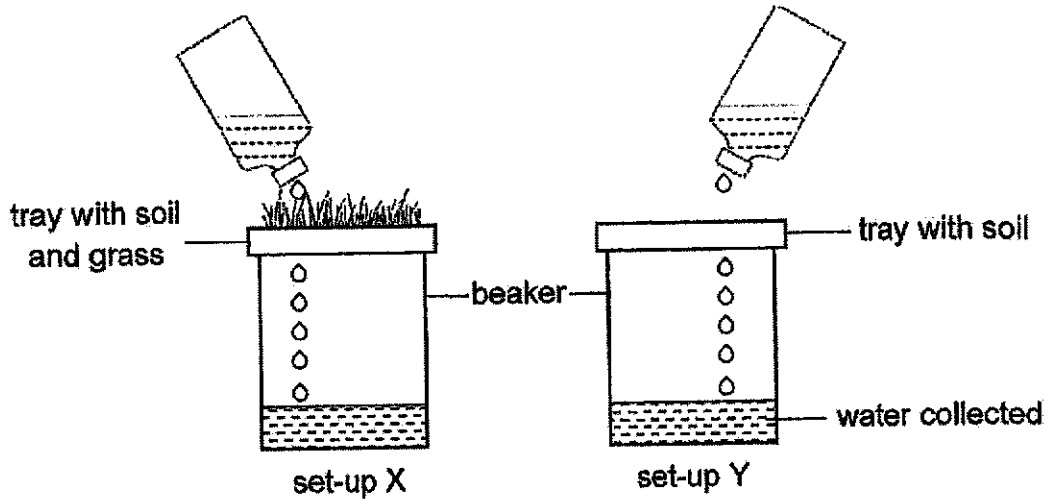

She placed a coin at the bottom of a large measuring cylinder as shown below. She poured water collected from the beaker in set-up X until the coin could no longer be seen and measured the height of water in the measuring cylinder.

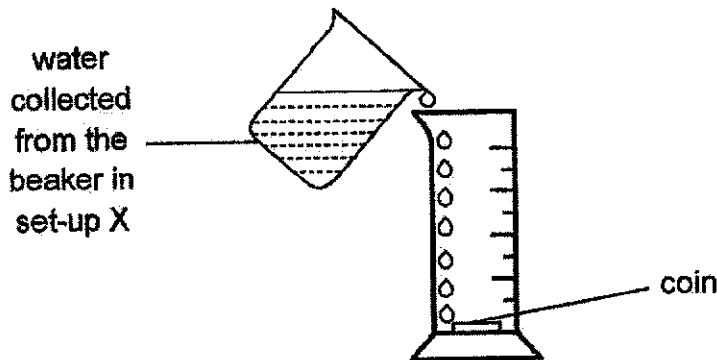

She repeated the same steps for the water collected from set-up Y. Her results are shown below.

	Water from set-up X	Water from set-up Y
Height of water (cm)	10	3

(a) Based on her results, what conclusion could she make?

[1]

There were two hills beside each other. One hill was covered with trees while the other had no trees. After a day of heavy rain, the hill without trees experienced a landslide as shown below but not the hill with trees.

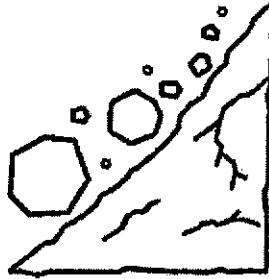

(b) How does growing trees on hills prevent the landslide?

[1]

Score	2
-------	---

33 Jane conducted an experiment using two identical test tubes as shown below.

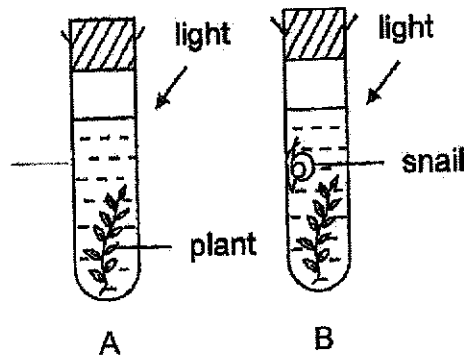

(a) After a few hours, bubbles were seen coming out from the underside of the leaves in both test tubes. State what gas these bubbles contain. [1]

(b) Jane noticed that there were more bubbles produced by the plant in test tube B compared to test tube A. Explain why [2]

Jane carried out another experiment in a dark room using a tank divided into two sections by black plastic sheets as shown below. Only one of the torches was switched on.

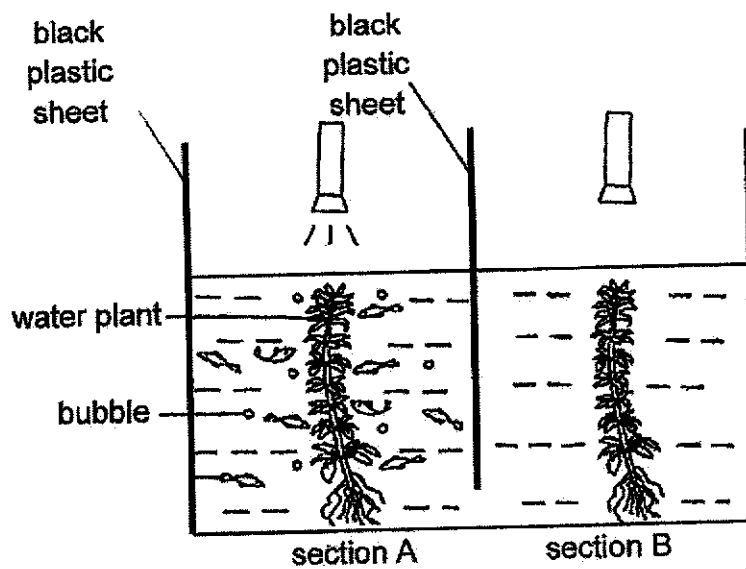

Score	3
-------	---

(c) Based on the diagram, explain why the fish were found in section A only. [1]

34 Study the information below about organisms P, Q, R, S and T.

P	Q	R	S	T
depends on Q and T to disperse its seeds	is a plant-eater	eats Q	eats both R and T	is a plant-eater

(a) Draw a food web to show the relationship among the organisms, P, Q, R, S and T. [2]

(b) If R is wiped out due to a disease, explain what will happen to the population of T. [1]

Score	4
-------	---

35 Organism X grows in soil that is poor in nutrients in the forest. It is adapted to digest insects.

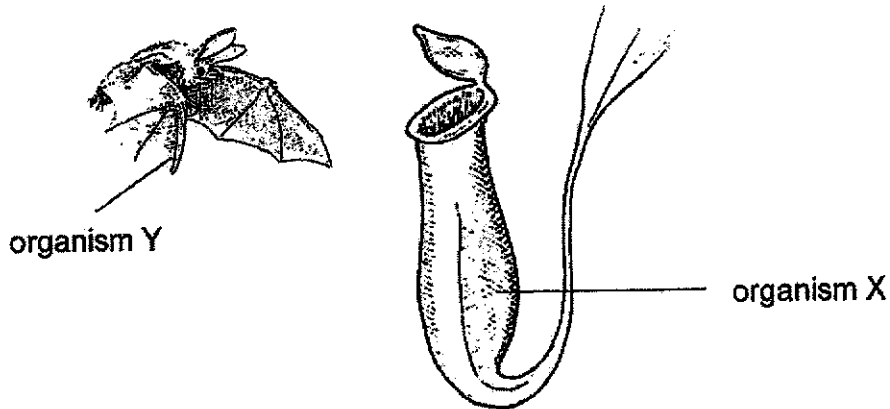

Organism Y goes into organism X to rest in the day instead of hanging from a tree in the forest. Organism Y produces droppings when it is resting inside organism X. Organism Y only feeds on fruits.

(a) How do both organisms benefit from this relationship? [2]

(b) To clear more land for buildings, deforestation is carried out. Explain how deforestation affects the population of organism Y in this forest. [1]

Score	3
-------	---

36 Chefs make soup dumplings by wrapping frozen pieces of soup with the meat filling inside a dumpling skin. The dumplings are steamed before eating.

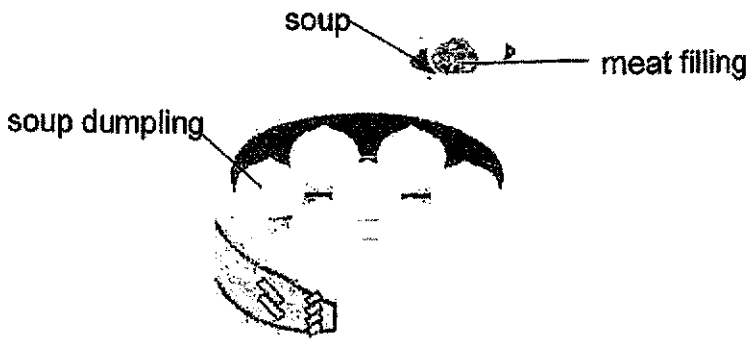

(a) Explain how liquid soup is found inside the cooked dumplings. [1]

(b) Why is it easier for chefs to wrap up frozen pieces of soup instead of liquid soup? [1]

Score	2
-------	---

Hannah packed some hot soup dumplings in a dry container to take home. When she opened the container at home, she observed many water droplets on the inner surface of the lid of the container as shown below.

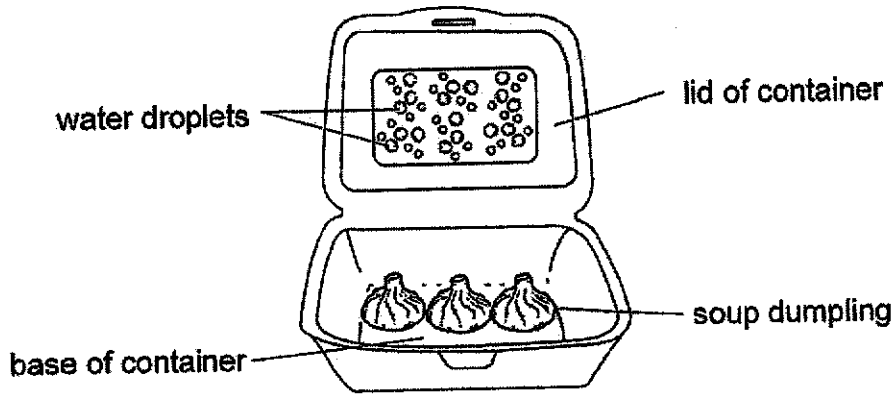

(c) Explain how the water droplets on the lid were formed. [2]

(d) The soup dumplings were soaking in small pool of water at the base of the container. What should Hannah do to the container to prevent the dumplings from being soaked in a pool of water when she reached home? [1]

Score	3
-------	---

- 37 Xiaohui wanted to find out how much light could pass through materials, D, E, F and G. She set up her experiment in a dark room as shown below.

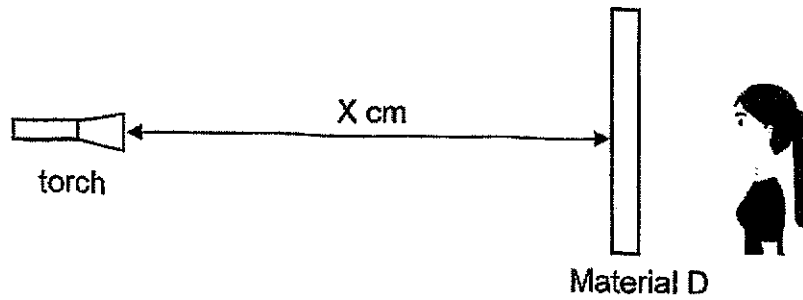

She held material D and walked towards the torch until she could see the light from the torch passing through the material. She then measured the distance X between the torch and material D. She repeated the step with materials, E, F and G, and recorded the results as shown below.

Material	Distance X (cm)
D	80
E	50
F	100
G	20

- (a) Based on Xiaohui's results, which material is most suitable for making curtains to cover the entrance of a changing room? Explain your answer. [1]

- (b) State two variables Xiaohui should keep constant to ensure a fair test. [2]

Xiaohui's teacher suggested that she could use a light sensor to measure the amount of light passing through the materials.

- (c) How does using a light sensor improve the results of her experiment? [1]

38 Faizal pushed a toy that is attached to a spring into a container and covered it with a lid. The toy popped up when he removed the lid.

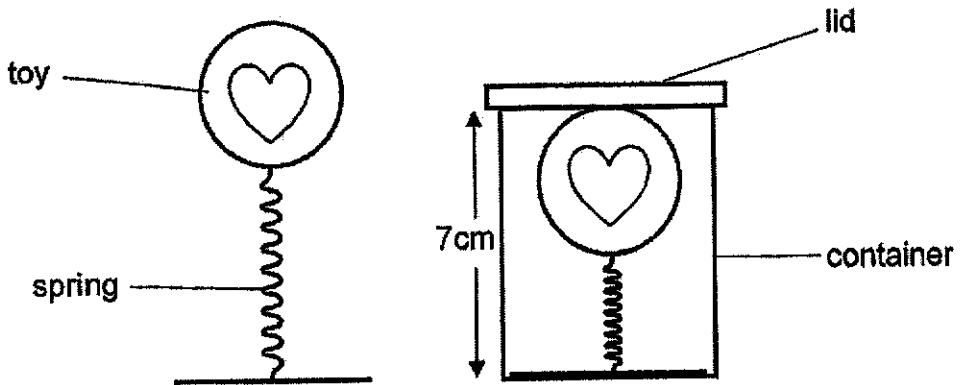

(a) State two forces acting on the toy when Faizal removed the lid. [1]

(b) When Faizal pushed the toy into another container of height 5 cm, he discovered that he needed to use a heavier lid to prevent the toy from popping up. Explain why. [2]

Score	3
-------	---

- 39 In the set-up below, the bar magnet is repelled by the electromagnet when the circuit is closed. The pointer attached to the spring moves.

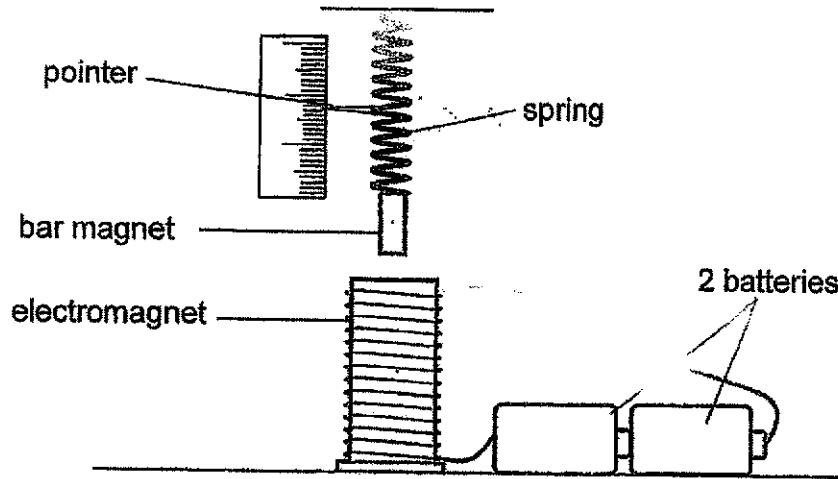

The diagram below shows the reading for the set-up above.

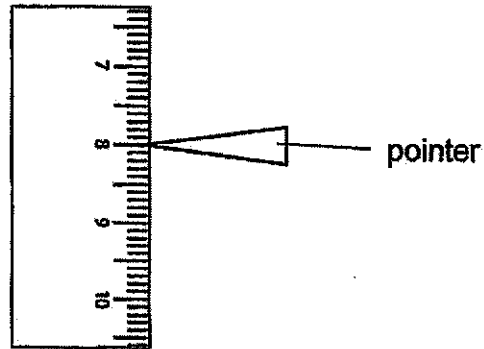

- (a) What could be a possible reading if the spring is replaced with a less stiff spring? [1]

_____ cm

- (b) How will the pointer move when only 1 battery is used? Explain your answer. [2]

Score	3
-------	---

40 Bala played a game that required him to throw a ball to knock over some cans. He must knock over all the cans to win.

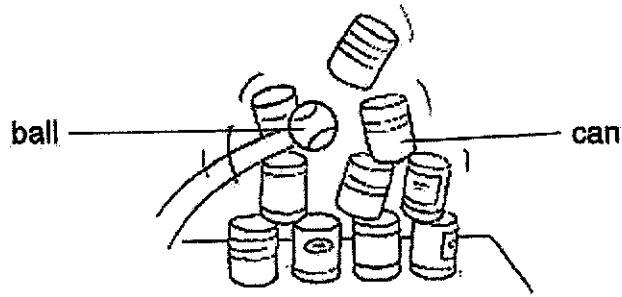

(a) Fill in the boxes to show the energy conversion when the ball hits the cans. [1]

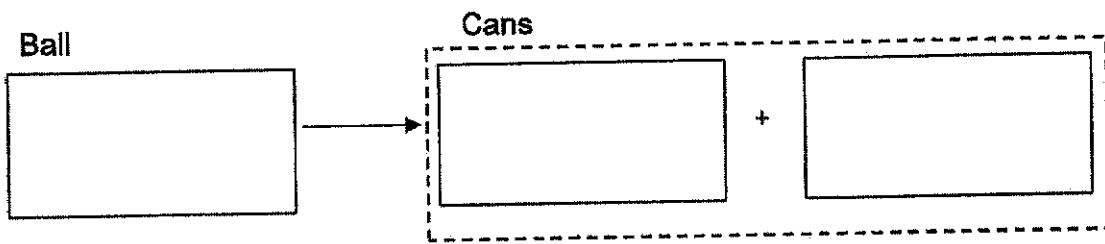

Bala could choose either ball X or ball Y to throw. The diameter and mass of the balls are shown below.

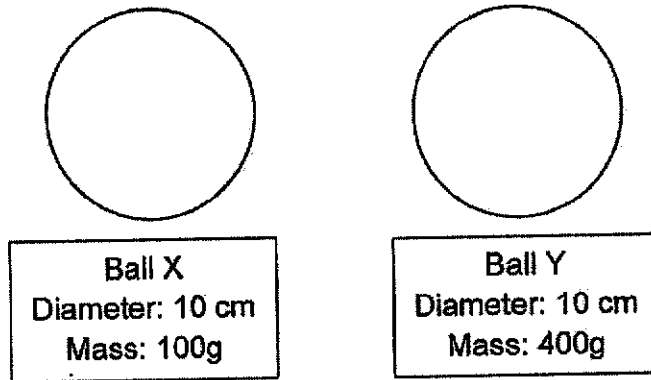

(b) If Bala throws the balls at the same speed, which ball should Bala choose to give him a higher chance of winning? Explain your answer in terms of energy conversion. [2]

Score	3
-------	---

- 41 A restaurant uses an appliance that has 4 identical heating lamps to keep food warm. When the lamps are brighter, they give off more heat.

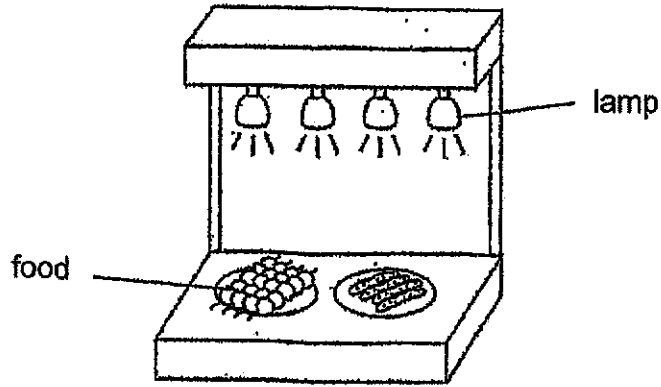

- (a) Complete the circuit diagram below to show how the lamps can give off the most heat. [2]

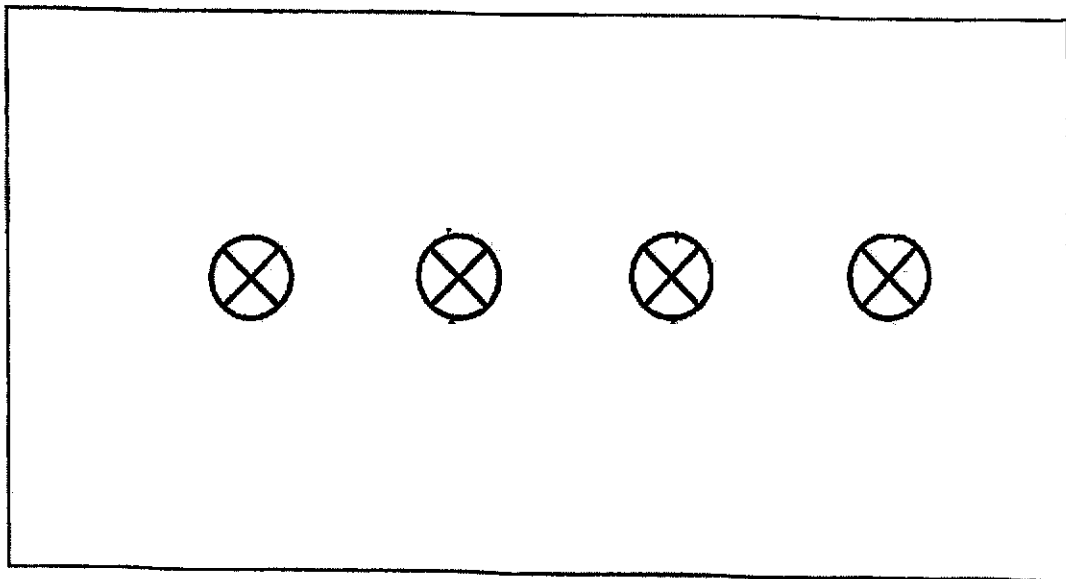

- (b) In your circuit diagram above, draw a switch at a position that can control all 4 lamps at the same time. [1]
- (c) Without changing the bulbs, suggest one way the restaurant can conserve electricity to keep fewer dishes of food warm while using the appliance. [1]

End of Paper

Score	4
-------	---

SCHOOL : TAO NAN PRIMARY SCHOOL
LEVEL : PRIMARY 6
SUBJECT : SCIENCE
TERM : 2024 PRELIM

Q 1	Q2	Q3	Q4	Q5	Q6	Q7	Q8	Q9	Q10
2	4	2	4	3	4	4	1	3	2
Q 11	Q12	Q13	Q14	Q15	Q16	Q17	Q18	Q19	Q20
4	2	3	4	3	3	2	4	3	1
Q 21	Q22	Q23	Q24	Q25	Q26	Q27	Q28		
4	2	4	3	2	2	4	4		



Tao Nan School
P6 Science Preliminary Examination 2024
Simplified Answer Key (Booklet B)

Name: _____ ()

Class: 6 _____

This answer key only serves as a reference. Variations of students' answers have been accepted if they have shown conceptual understanding.

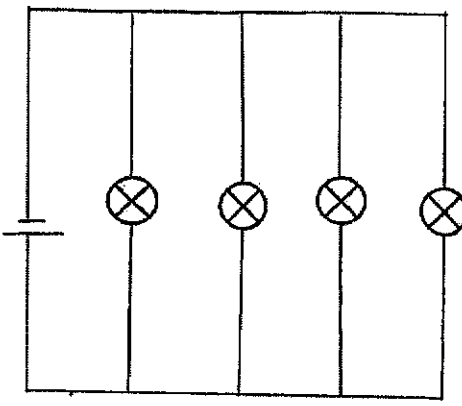
Qn	Suggested Answer
29a	The holes allow air/oxygen to enter for the grasshopper to breathe / respire.
b	Grasshopper needs food to survive.
c	Set-up A acts as a control to confirm/ensure that the grasshopper in set-up B survived only due to the presence of food.
30a	Wind
b	Anther is dangling outside the flower so pollen grains can be blown/carried by wind or Stigma is feathery / dangling outside the flower to catch the pollen grain / to increase surface area for the pollen grain to land on.
c	He can add fans in the greenhouse or open the doors/windows of the greenhouse.
31a	(Any two) Heart, blood/blood stream, blood vessels/arteries/veins/capillaries
b	To transport oxygen / digested food / water / carbon dioxide / waste (any 2 substances) around the body.
c	He breathes faster to inhale or take in more/sufficient oxygen. His heart would need to pump (blood) faster/more times to ensure enough/sufficient/more oxygen is transported to his body.
32a	The presence of grass decrease the amount of soil particles washed into the water or the presence of grass affects the amount of soil particles washed into the water.
b	Roots (of trees) hold onto the soil, preventing the soil from being washed away.
33a	Oxygen
b	The snail respired or gave out/breathed out/exhaled carbon dioxide. With more carbon dioxide, the plant photosynthesised faster/made more food to produce more oxygen. (Need to compare)
c	Only the plant in A made food/photosynthesised and produced oxygen for the fish (Need to compare and mention about photosynthesis)
34a	$P \rightarrow Q \rightarrow R \rightarrow S$
b	The population of T will decrease as S will eat more T since there is no more R for S to eat.
35a	Organism Y can hide from predators. Organism Y's waste/droppings provide nutrients for Organism X (to grow more healthily).
b	The population of Organism Y will decrease as its habitat is destroyed/it is killed/X will not have a place to grow hence there is no place for Y to hide from predators.

36a	The frozen pieces of soup melted . or The frozen pieces gained heat and turned from solid (state) to liquid (state).
b	Solids have a definite shape but liquids do not. (Need to compare)
c	The water vapour in the container gained heat from the hot soup dumplings/ Water vapour from the hot soup dumplings came into contact with the cooler inner surface of the lid and condensed into water droplets.
d	Poke holes in the container/ do not close the lid of the container/ leave the container open
37a	Material G. It allows the least amount of light to pass through so people cannot see into the changing room clearly. (Need to compare)
b	(Any two) Thickness of the materials Intensity of the light Distance between Xiaohui's eyes and the material
c	Her results would be more accurate.
38a	(Any two) Elastic spring force, gravitational force, frictional force Spring
b	The spring is more compressed/ compressed further/ compressed to a shorter height so the toy will exert a greater elastic spring force (on the lid/toy), pushing up the lid more. A heavier lid will exert a greater downward force to keep the toy from jumping out.
39a	Any value less than 8cm
b	When 1 battery is used, the strength of the electromagnet decreases. There is less magnetic force of repulsion pushing the bar magnet up so pointer will move downwards.
40a	Kinetic energy, Kinetic energy, sound/heat energy
b	Ball Y. It has more mass. It will have more kinetic energy when thrown so more kinetic energy can be transferred to the cans when the ball hits the cans.
41a	
b	Switch drawn at main path which can control all the bulbs in the circuit 
c	Add switches to control the bulbs individually

