



NANYANG PRIMARY SCHOOL

**MID-YEAR PRACTICE
2024**

PRIMARY 6

**MATHEMATICS
PAPER 1
(BOOKLET A)**

Total Duration for Booklets A and B: 1 hour

Additional materials: Optical Answer Sheet (OAS)

INSTRUCTIONS TO PUPILS

1. Do not turn over this page until you are told to do so.
2. Follow all instructions carefully.
3. Answer all questions.
4. Shade your answers in the Optical Answer Sheet (OAS) provided.
5. The use of calculators is **NOT** allowed.

Name: _____ ()

Class: Primary 6 ()

Questions 1 to 10 carry 1 mark each. Questions 11 to 15 carry 2 marks each. For each question, four options are given. One of them is the correct answer. Make your choice (1, 2, 3 or 4) and shade your answer on the Optical Answer Sheet. (20 marks)

- 1 Part of a scale is shown below. What is the value of the reading at X?

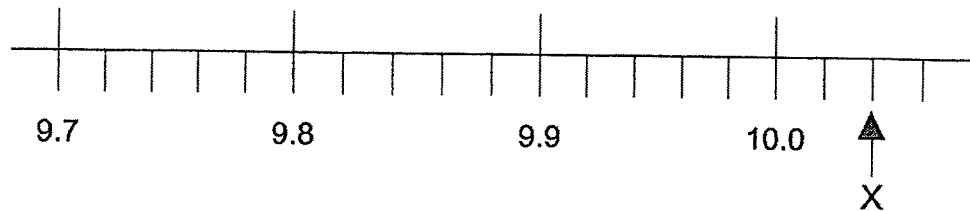

- (1) 10.02
 (2) 10.04
 (3) 10.2
 (4) 10.4
- 2 Find the value of $\frac{5}{6} \div \frac{1}{4}$

- (1) $\frac{10}{3}$
 (2) $\frac{5}{24}$
 (3) $\frac{3}{10}$
 (4) $\frac{24}{5}$

- 3 Joyce baked some cookies. She gave 80% of the cookies to Zac. Zac ate 20% of the cookies he received from Joyce. Which one of the following shows the percentage of total cookies that Zac ate?

(1) $\frac{1}{5} \times 20\%$

(2) $\frac{1}{5} \times 80\%$

(3) $\frac{4}{5} \times 80\%$

(4) $\frac{4}{5} \times 100\%$

- 4 The square grid below shows Triangle P. What type of triangle is Triangle P?

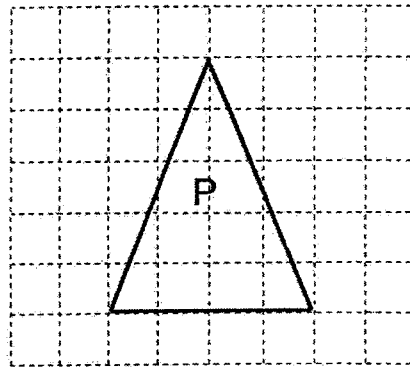

- (1) Obtuse-angled triangle
(2) Right-angled triangle
(3) Equilateral triangle
(4) Isosceles triangle

5 In the square grid below, which shape is a rhombus?

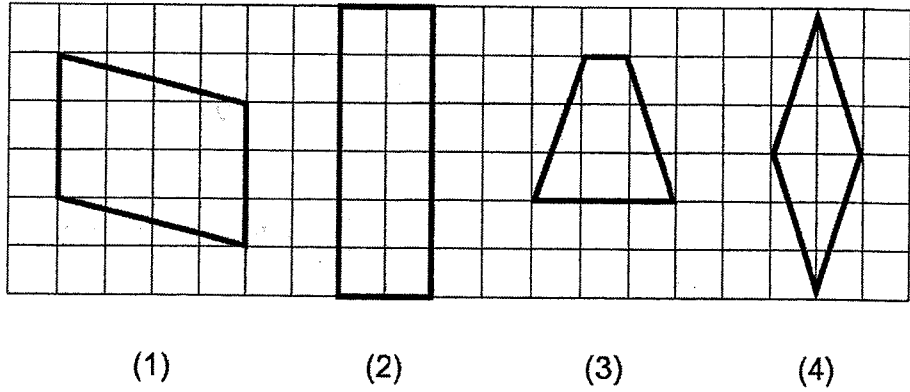

6 What is the area of triangle ABC as shown in the figure?

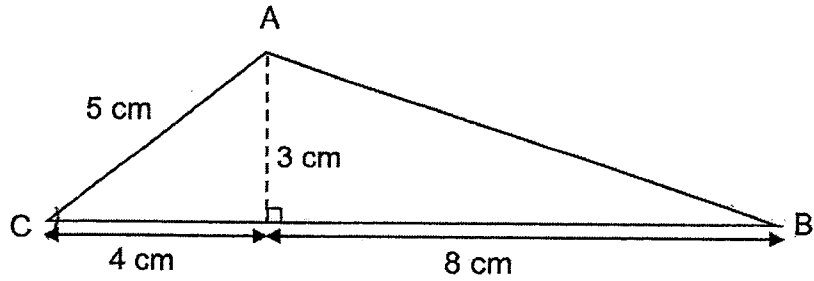

- (1) 18 cm^2
- (2) 20 cm^2
- (3) 30 cm^2
- (4) 36 cm^2

7 What is the area of a circle with diameter 60 cm?
(Take $\pi = 3.14$)

- (1) 94.2 cm²
- (2) 188.4 cm²
- (3) 2826 cm²
- (4) 11 304 cm²

- 8 Which of the following is likely to be the length of an approved scientific calculator for PSLE?

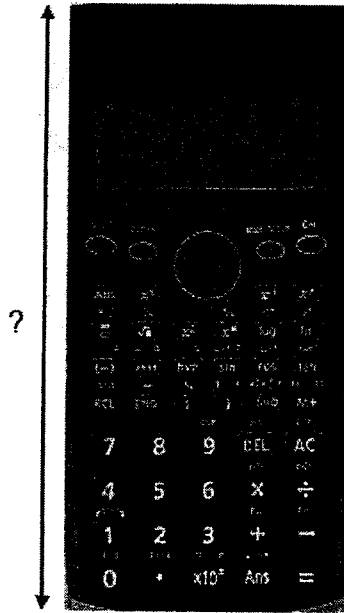

- (1) 0.018 m
- (2) 0.18 m
- (3) 1.8 m
- (4) 18 m

Use the information below to answer questions 9 and 10.

The bar graph below shows the number of cars sold from June to September.

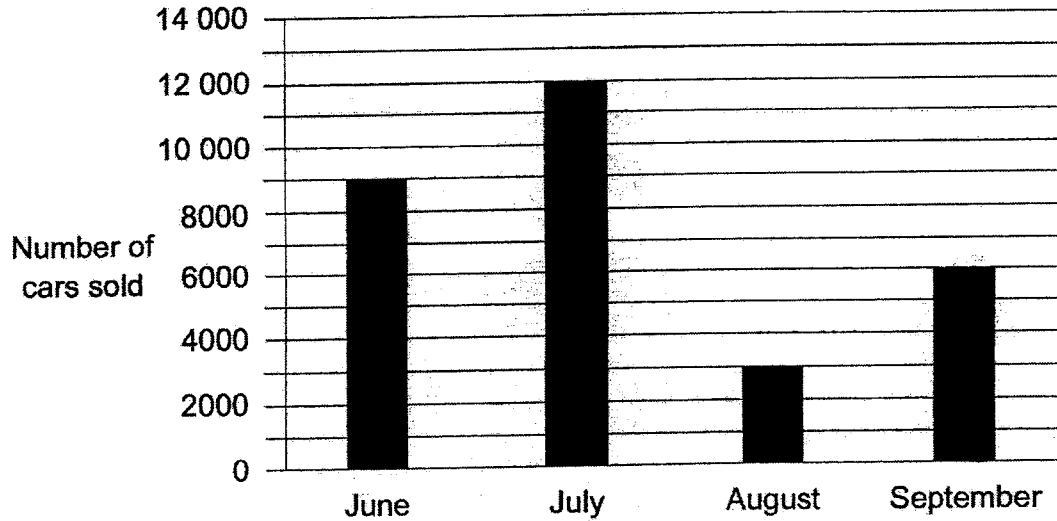

9 In which month was the number of cars sold half as many as the number of cars sold in September?

- (1) June
- (2) July
- (3) August
- (4) September

- 10 Which one of the following statements is true?
- (1) The number of cars sold in June was 8500.
 - (2) The number of cars sold in July is $\frac{3}{4}$ the number of cars sold in June.
 - (3) The increase in the number of cars sold from August to September was 9000.
 - (4) The total number of cars sold in June and August is the same as the number of cars sold in July.
- 11 Last month, a florist sold 800 roses. This month, she sold 1000 roses. What was the percentage increase in the number of roses sold?
- (1) 20%
 - (2) 25%
 - (3) 80%
 - (4) 200%

- 12 The figure below is made up of 3 identical quarter circles of radius 28 cm. Find its perimeter. (Take $\pi = \frac{22}{7}$)

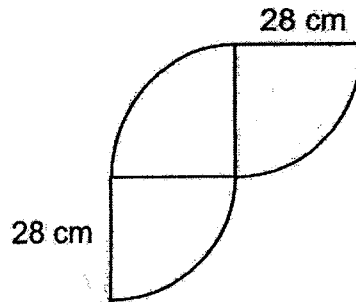

- (1) 132 cm
(2) 176 cm
(3) 188 cm
(4) 232 cm
- 13 A lollipop cost \$0.70. There were 80 lollipops in a box. Janie bought 8 such boxes of lollipops for her class party. How much did she spend on the lollipops?

- (1) \$408
(2) \$428
(3) \$448
(4) \$560

- 14 At first, a rectangular tank measuring 40 cm by 30 cm by 30 cm contained some water as shown below.

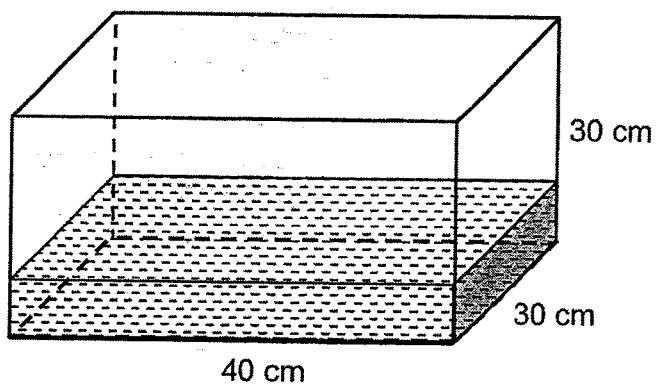

After Melvin poured 1500 ml of water into the tank, the tank became $\frac{1}{3}$ -filled with water. How much water was there in the tank at first?

- (1) 10 500 cm³
- (2) 12 000 cm³
- (3) 13 500 cm³
- (4) 36 000 cm³

- 15 In a basket, $\frac{5}{9}$ of the fruits are apples and the rest are oranges. $\frac{3}{10}$ of the apples are green in colour. There are 15 green apples. How many fruits are there in the basket?

- (1) 45
- (2) 50
- (3) 90
- (4) 135



NANYANG PRIMARY SCHOOL

**MID-YEAR PRACTICE
2024**

PRIMARY 6

**MATHEMATICS
PAPER 1
(BOOKLET B)**

Total Duration for Booklets A and B: 1 hour

INSTRUCTIONS TO PUPILS

1. Do not turn over this page until you are told to do so.
2. Follow all instructions carefully.
3. Answer all questions.
4. Write your answers in this booklet.
5. The use of calculators is **NOT** allowed.

Name: _____ ()

Class: Primary 6 ()

Booklet B

/ 25

Please sign and return the paper the next day. Any queries should be raised at the same time when returning paper.

Questions 16 to 20 carry 1 mark each. Write your answers in the spaces provided. For questions which require units, give your answers in the units stated. (5 marks)

16 Express $3\frac{1}{4}$ as a decimal.

Ans: _____

17 The volume of a cube is 1000 cm^3 . Find the length of one edge of the cube.

Ans: _____ cm

- 18 John stacked 7 unit cubes and glued them together to form the solid below.

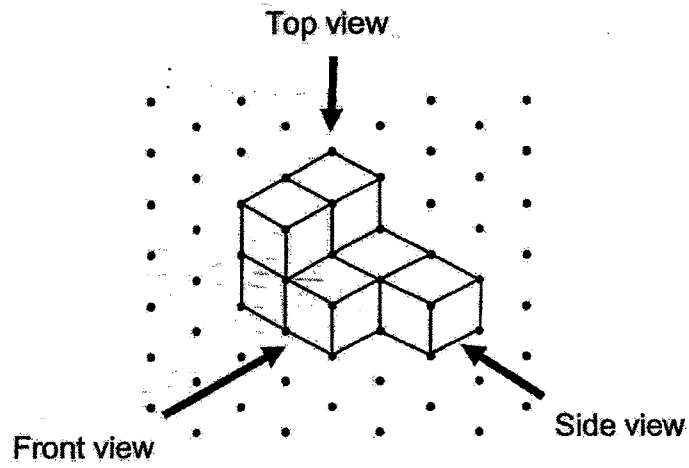

Draw the top view of the solid on the grid below.

Top View

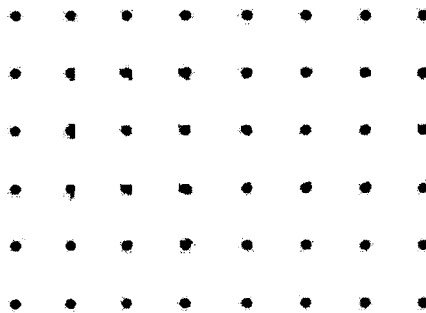

- 19 In the figure below, ACD and BCE are straight lines.
 $\angle ABE = 55^\circ$, $\angle DEB = 114^\circ$ and $\angle DAB = 90^\circ$. Find $\angle ADE$.

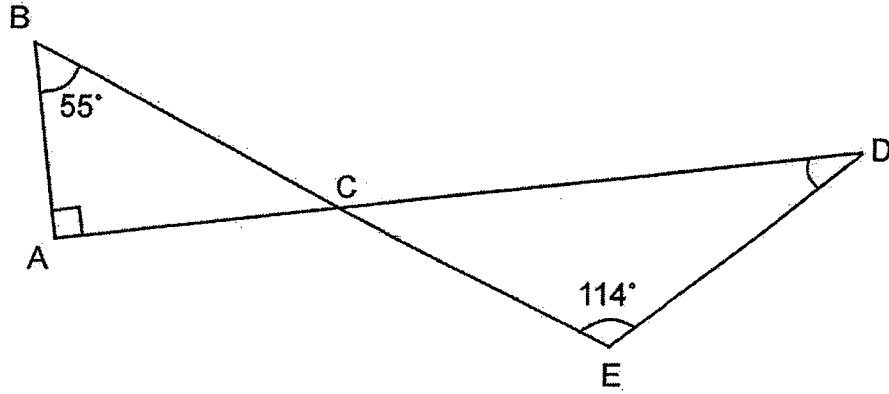

Ans: _____ °

- 20 In the figure below, WXYZ is a trapezium and WX is parallel to ZY.
 $\angle WXY = 56^\circ$ and $\angle WZY = 66^\circ$. Find $\angle XWZ$.

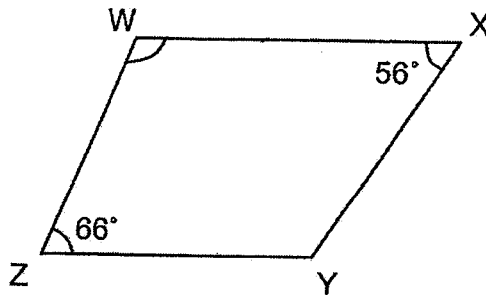

Ans: _____ °

Questions 21 to 30 carry 2 marks each. Show your working clearly and write your answers in the spaces provided. For questions which require units, give your answers in the units stated. (20 marks)

- 21 In the figure, ABCD is a rectangle. $BD = BE$, $\angle BED = 40^\circ$ and $\angle EDA = 260^\circ$. Find $\angle CDB$.

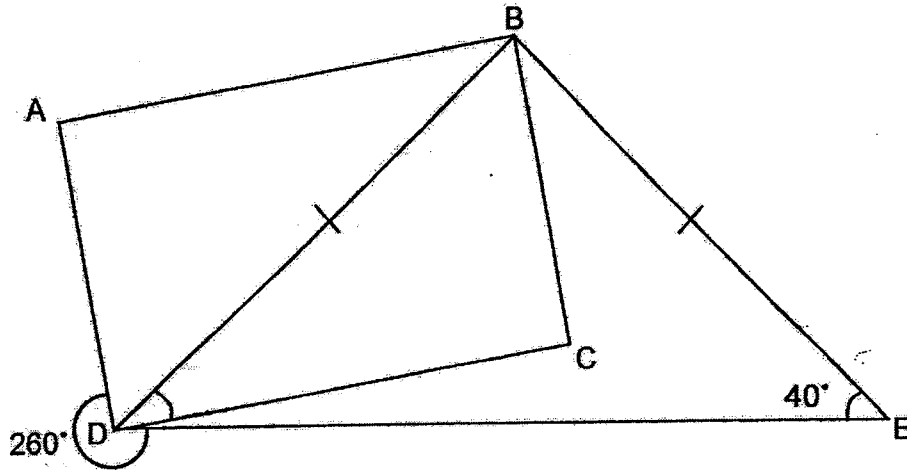

Ans: _____°

- 22 Find the circumference of a circle of diameter 28 m. (Take $\pi = \frac{22}{7}$)

Ans: _____ m

- 23 The figure below shows a square and a quarter circle. The length of the square is 20 cm. Find the area of the shaded part. (Take $\pi = 3.14$)

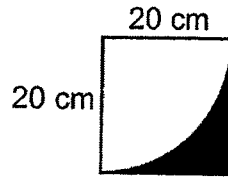

Ans: _____ cm²

- 24 A straight line EF is drawn on a square grid inside a box.

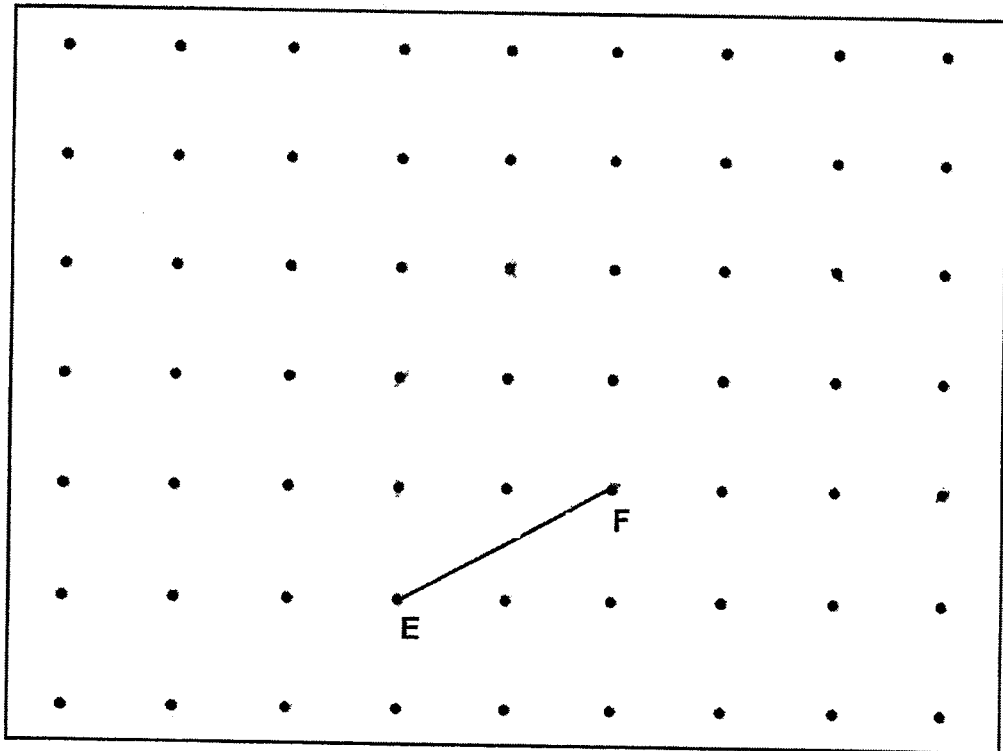

G is one of the dots inside the box. Draw two lines FG and EG to complete triangle EFG with $\angle EFG = 90^\circ$ and $EF = FG$.

- 25 A cuboid is 0.4 m long and 20 cm wide. It has a volume of 20 000 cm³. Find the height of the cuboid.

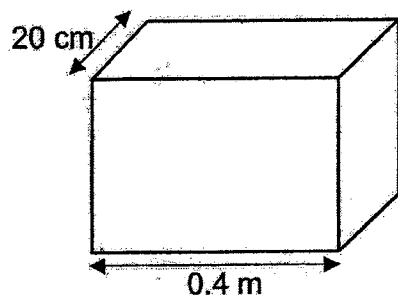

Ans: _____ cm

26 In a school hall, chairs were arranged in rows such that there were exactly 9 chairs in a row.

For a concert, Mr Ong brought 6 more chairs into the school hall and rearranged all the chairs. There are now exactly 7 chairs in each row and 12 more rows than before.

How many chairs are there in the school hall for the concert?

Ans: _____

- 27 A total of 110 people stand in a queue for concert tickets. There are at least 3 women between any 2 men. What is the largest possible number of men in the queue?

Ans: _____

- 28 Liyan had a bottle of syrup. She used an equal amount of syrup each day. At the end of the 12th day, $\frac{1}{3}$ of the bottle was left. At the end of the 14th day, the amount of syrup left was 200 ml. What was the amount of syrup in the bottle at first?

Ans: _____ ml

- 29 The block of wood shown below was dipped into a pail of paint. The block was then cut into 4 identical cubes along the dotted lines and taken apart. The total unpainted area of the 4 cubes was 150 cm^2 .

What was the volume of each cube?

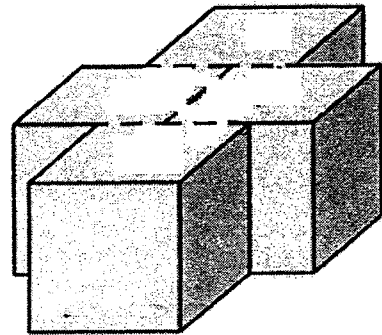

Ans: _____ cm^3

- 30 Three girls used the same number of beads to make necklaces. Devi used $\frac{2}{5}$ of her beads, Esther used $\frac{3}{8}$ of hers and Farah used $\frac{2}{3}$ of hers. They had a total of 1440 beads at first. How many beads did each girl use?

Ans: _____

End of Paper



NANYANG PRIMARY SCHOOL

**MID-YEAR PRACTICE
2024**

PRIMARY 6

**MATHEMATICS
PAPER 2**

Duration: 1 hour 30 minutes

INSTRUCTIONS TO PUPILS

1. Do not turn over this page until you are told to do so.
2. Follow all instructions carefully.
3. Answer all questions.
4. Write your answers in this booklet.
5. The use of an approved calculator is allowed.

Name: _____ ()

Class: Primary 6 ()

Parent's Signature: _____

| | |
|------------------|--------------|
| Booklet A | / 20 |
| Booklet B | / 25 |
| Paper 2 | / 55 |
| Total | / 100 |

Please sign and return the paper the next day. Any queries should be raised at the same time when returning paper.

Questions 1 to 5 carry 2 marks each. Show your working clearly and write your answers in the spaces provided. For questions which require units, give your answers in the units stated. (10 marks)

- 1 The table below shows the number of storybooks read by each student in a class. Part of the table is covered by an ink blot. There were 20 students who read less than 3 storybooks. There were twice as many students who read 3 storybooks as those who read 5 storybooks.

| | | | | | |
|----------------------|---|---|---|---|---|
| Number of storybooks | 1 | 2 | 3 | 4 | 5 |
| Number of students | 9 | | | 3 | 4 |

- (a) How many students read 2 storybooks?

Ans: (a) _____

- (b) How many students were there in the class?

Ans: (b) _____

- 2 A wheel of diameter 40 cm made 10 complete turns. Find the distance covered. (Take $\pi = 3.14$)

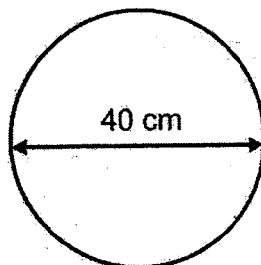

Ans: _____ cm

- 3 The price of a pair of shoes was \$80 before discount. Richard bought the pair of shoes at a discount of 15% during a sale. How much did he pay for the pair of shoes?

Ans: \$ _____

- 4 Water from a tap leaks at a rate of 15 ml per min. At this rate, how much water is leaked in 2 hours? Give your answer in litres.

Ans: _____ l

- 5 The average of four 3-digit numbers is 250. Two of the numbers are 190 and 230. What is the largest difference between the other two numbers?

Ans: _____

For questions 6 to 17, show your working clearly and write your answers in the spaces provided. The number of marks available is shown in brackets [] at the end of each question or part-question. (45 marks)

- 6 The figure shows an empty tank placed below two taps E and F. It takes 12 min to fill the tank with Tap E alone and 8 min with Tap F alone.

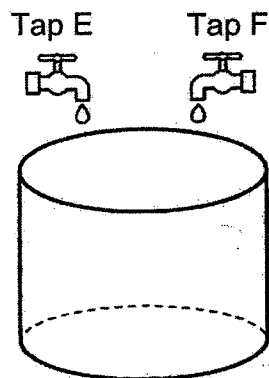

- (a) With only Tap E turned on, what fraction of the tank will be filled in 1 min?

Ans: (a) _____ [1]

- (b) Starting with an empty tank, how long does it take for both taps together to fill $\frac{1}{3}$ of the tank? Give your answer in seconds.

Ans: (b) _____ [2]

- 7 In the figure below, PQRS is a rectangle and QRT is a right-angled triangle with sides measuring 30 cm, 40 cm and 50 cm. The perimeter of the shaded part is 174 cm.

What is the ratio of the area of the triangle to the area of the shaded part?
Give your answer in the simplest form.

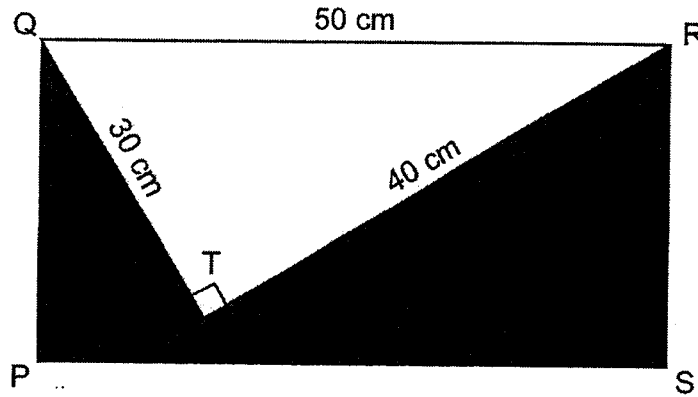

Ans: _____ [3]

- 8 Nurul and Peili went shopping together with a total sum of \$60. Nurul spent twice as much as Peili. The amount Peili had left was \$7 more than what she had spent. She had twice as much money left as Nurul. How much money did Nurul have at first?

Ans: _____ [3]

- 9 Pedro had a 700-cm long rope. He cut it into 3 pieces, A, B and C. The length of rope A was divisible by 3 and 7. The length of rope B was 4 times the length of rope A. The total length of rope A and rope B was less than 450 cm. The length of rope C was longer than the length of rope A but shorter than the length of rope B.

(a) What was the length of rope C? : _____

Ans: (a) _____ [2]

(b) What was the total length of rope A and rope B?

Ans: (b) _____ [1]

- 10 In the figure below, JKLM is a rhombus. MNK is a straight line and $MN = ML$. $\angle MNL$ is 24° more than $\angle LMN$. Find $\angle MJK$.

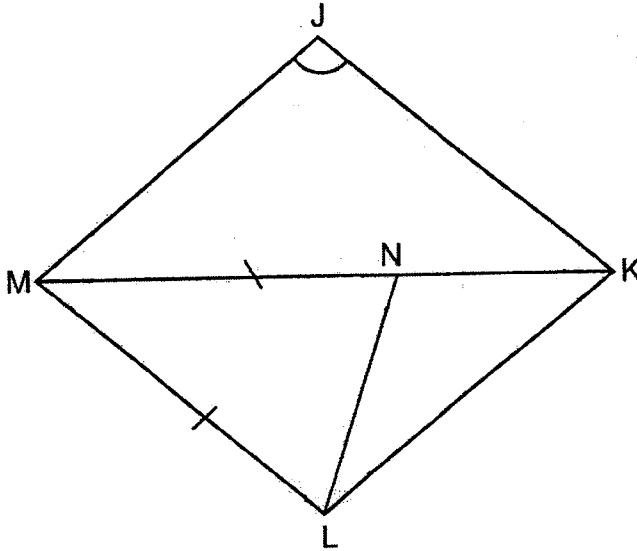

Ans: _____ [3]

- 11 In the figure below, ABCD is a trapezium. E is a point on AD such that $AB = BE$. $\angle BCD = 62^\circ$ and $\angle CDE = 110^\circ$.

Find $\angle EBC$.

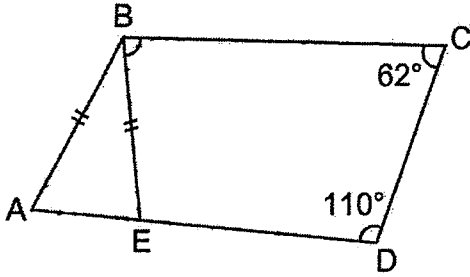

Ans: _____ [4]

- 12 At first, Lisa had a total of 66 blue and pink balloons. 17 pink balloons burst. She then increased the number of blue balloons by 75%. After that, Lisa had a total of 79 balloons. How many pink balloons did she have at first?

Ans: _____ [4]

- 13 A rectangular tank with a base area of 3500 cm^2 and a height of 80 cm was $\frac{1}{4}$ -filled with water at first. At 8 a.m., a tap was turned on and water was drained from the tank at the rate of 4 litres per minute. At 8.06 a.m., the tap was turned off.

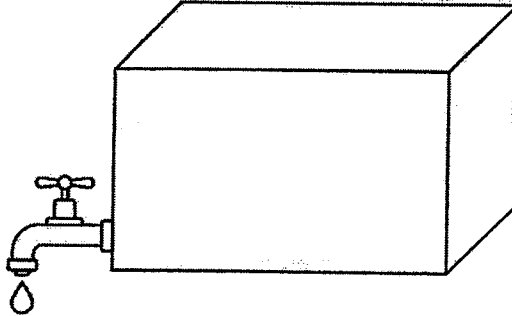

- (a) How much water was drained from the tank?

Ans: (a) _____ [1]

- (b) After the tap was turned off, how much more water was needed to fill the tank completely?

Ans: (b) _____ [3]

- 14 Six identical rectangular boxes can be stacked into a cupboard 0.9 m wide. Two arrangements are shown below. The first arrangement in Figure A leaves a 42-cm gap at the top. The second one in Figure B leaves a 10-cm gap at the top and another gap at the side.

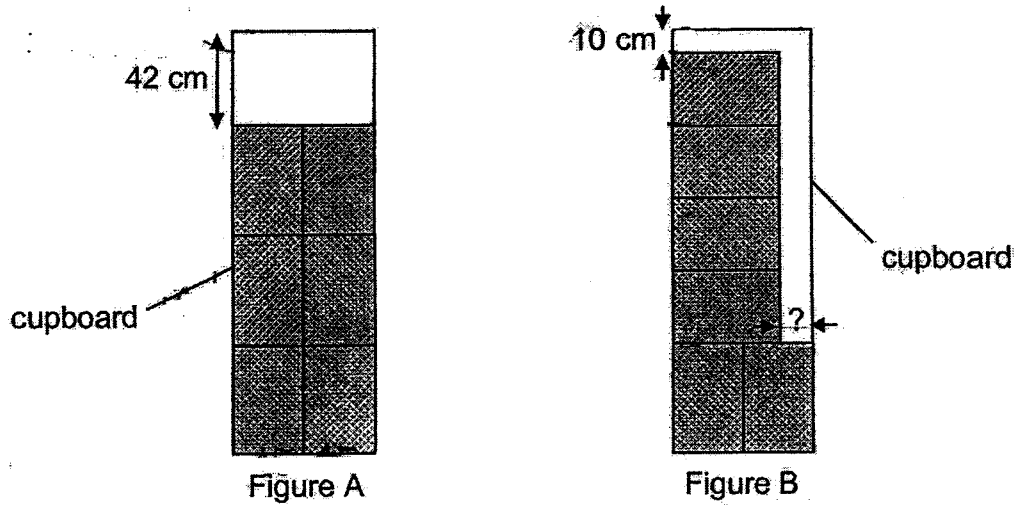

- (a) In the arrangement shown in Figure B, what is the width of the gap at the side?

Ans: (a) _____ [2]

- (b) What is the height of the cupboard in metres?

Ans: (b) _____ [2]

- 15 Kai Li spent $\frac{1}{3}$ of her money on 5 magnets and 11 postcards. The cost of each magnet is 3 times the cost of each postcard. She bought some more magnets with $\frac{3}{4}$ of her remaining money. How many magnets did Kai Li buy altogether?

Ans: _____ [4]

- 16 A symmetric figure is drawn on a rectangular piece of paper 20 cm by 15 cm as shown below. Its outline consists of a large semicircle, 2 smaller semicircles and 2 straight lines. (Take $\pi = 3.14$)

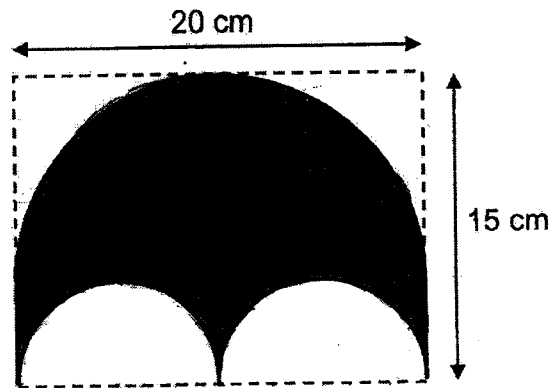

- (a) What is the area of the figure?

Ans: (a) _____ [3]

- (b) What is its perimeter?

Ans: (b) _____ [2]

- 17 Two pouches, Y and Z, contained some gold tokens and silver tokens at first. In Pouch Y, the ratio of the number of gold tokens to the number of silver tokens was 3 : 1. In Pouch Z, the ratio of the number of gold tokens to the number of silver tokens was 1 : 4. Pouch Z had 5 times as many tokens as Pouch Y.

- (a) What was the ratio of the number of gold tokens in Pouch Y to the number of silver tokens in Pouch Z?

Ans: (a) _____ [1]

- (b) After 24 gold tokens and 24 silver tokens were transferred from Pouch Z to Pouch Y, the ratio of the number of gold tokens to the number of silver tokens in Pouch Y became 9 : 5. What was the total number of tokens in Pouch Y in the end?

Ans: (b) _____ [2]

- (c) What was the total number of tokens in both pouches, Y and Z, at first?

Ans: (c) _____ [2]

End of Paper

SCHOOL : NANYANG SCHOOL
 LEVEL : PRIMARY 6
 SUBJECT : MATH
 TERM : SA1 2024

| | | | | | | | | | |
|-----|-----|-----|-----|-----|----|----|----|----|-----|
| Q1 | Q2 | Q3 | Q4 | Q5 | Q6 | Q7 | Q8 | Q9 | Q10 |
| 2 | 1 | 2 | 4 | 4 | 1 | 3 | 2 | 3 | 4 |
| Q11 | Q12 | Q13 | Q14 | Q15 | | | | | |
| 2 | 3 | 3 | 1 | 3 | | | | | |

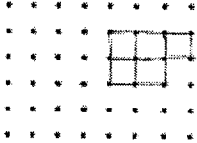
| |
|--|
| Q16) 3.25 |
| Q17) 10cm |
| Q18)  |
| Q19) $180 - 55 - 90 = 35^\circ$ $180 - 114 - 35 = 31^\circ$ |
| Q20) $180 - 66 = 114^\circ$ |
| Q21) $360 - 260 - 90 = 10^\circ$ $40 - 10 = 30^\circ$ |
| Q22) $\frac{22}{7} \times 28 = 88\text{m}$ |
| Q23) $3.14 \times 20 \times 20 = 1256$ $1256 \div 4 = 314$ $20 \times 20 = 400$ $400 - 314 = 86 \text{ cm}^2$ |

Q24)

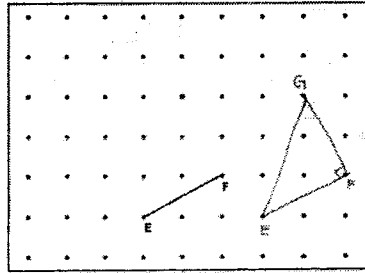

Q25) $0.4\text{m} = 40\text{cm}$
 $40 \times 20 = 800$

$$\frac{20000}{800} = 25\text{cm}$$

Q26) $12 \times 7 = 84$
 $84 - 6 = 78$
 $9 - 7 = 2$
 $78 \div 2 = 39$
 $39 \times 9 = 351$
 $351 + 6 = 357$

Q27) $110 - 1 = 109$
 $109 \div 4 = 27 \text{ R}1$
 $27 + 1 = 28$

Q28) 900ml

Q29) 125cm³

Q30) 216

PAPER 2

Q1) a) $20 - 9 = 11$
 b) $4 \times 2 = 8$
 $11 + 8 + 9 + 3 + 4 = 35$

Q2) $3.14 \times 40 = 125.6$
 $125.6 \times 10 = 1256 \text{ cm}$

Q3) $100\% \rightarrow 80$
 $1\% \rightarrow 80 \div 100 = 0.8$

| | | | | | | | | | | | | | | | | | | | |
|------|--|-----|---|---|-----|---|-----|-----|---|-----|----|---|----|----|---|----|---|---|---|
| | $100\% - 15\% = 85\%$ $85\% \rightarrow 0.8 \times 85 = \68 | | | | | | | | | | | | | | | | | | |
| Q4) | $2h = 120 \text{ min}$ $15 \times 120 = 1800$ $1800\text{ml} = 1.8\text{L}$ | | | | | | | | | | | | | | | | | | |
| Q5) | $250 \times 4 = 1000$ $1000 - 190 - 230 = 580$ $480 - 100 = 380$ | | | | | | | | | | | | | | | | | | |
| Q6) | a) $\frac{1}{12}$ b) 96 | | | | | | | | | | | | | | | | | | |
| Q7) | $174 - 50 - 30 - 40 = 54$ $54 \div 2 = 27$ $\frac{1}{2} \times 40 \times 30 = 600$ $50 \times 27 = 1350$ $1350 - 600 = 750$ ANS: 4 : 5 <table style="margin-left: auto; margin-right: 0;"> <tbody> <tr> <td>T</td> <td>:</td> <td>S</td> </tr> <tr> <td>600</td> <td>:</td> <td>750</td> </tr> <tr> <td>120</td> <td>:</td> <td>150</td> </tr> <tr> <td>24</td> <td>:</td> <td>30</td> </tr> <tr> <td>12</td> <td>:</td> <td>15</td> </tr> <tr> <td>4</td> <td>:</td> <td>5</td> </tr> </tbody> </table> | T | : | S | 600 | : | 750 | 120 | : | 150 | 24 | : | 30 | 12 | : | 15 | 4 | : | 5 |
| T | : | S | | | | | | | | | | | | | | | | | |
| 600 | : | 750 | | | | | | | | | | | | | | | | | |
| 120 | : | 150 | | | | | | | | | | | | | | | | | |
| 24 | : | 30 | | | | | | | | | | | | | | | | | |
| 12 | : | 15 | | | | | | | | | | | | | | | | | |
| 4 | : | 5 | | | | | | | | | | | | | | | | | |
| Q8) | $9u + \$7 + \$3.50 = \$60$ $9u = \$60 - \$7 - \$3.50 = \49.50 $1u = \$49.50 \div 9 = \5.50 $5u = \$5.50 \times 5 = \27.50 $\$27.50 + \$3.50 = \$31$ | | | | | | | | | | | | | | | | | | |
| Q9) | a) 280cm b) $700 - 280 = 420 \text{ cm}$ | | | | | | | | | | | | | | | | | | |
| Q10) | $180 - 24 - 24 = 132^\circ$ $132 \div 3 = 44^\circ$ $44 + 24 = 68^\circ$ $180 - 68 = 112^\circ$ $180 - 112 - 44 = 24^\circ$ $24 + 68 = 92^\circ$ | | | | | | | | | | | | | | | | | | |
| Q11) | $180 - 110 = 70^\circ$ $180 - 70 - 70 = 40^\circ$ $180 - 62 - 40 = 78^\circ$ | | | | | | | | | | | | | | | | | | |

| | |
|------|---|
| Q12) | $66 - 17 = 49$ $79 - 49 = 30$ $75\% \rightarrow 30$ $1\% \rightarrow 30 \div 75 = 0.4$ $100\% \rightarrow 0.4 \times 100 = 40$ $66 - 40 = 26$ |
| Q13) | <p>a) $4L = 4000ml = 4000cm^3$ $4000 \times 6 = 24000cm^3$</p> <p>b) $3500 \times 80 = 280000$ $280000 \div 4 = 70000$ $70000 - 24000 = 46000$ $280000 - 46000 = 234000 \text{ ml}$</p> |
| Q14) | <p>a) $2B \rightarrow 90$ $1B \rightarrow 90 \div 2 = 45$ $4B \rightarrow 45 \times 4 = 180$ $180 + 10 = 190$ $190 - 42 = 148$ $148 \div 2 = 74$ $90 - 74 = 16cm$</p> <p>b) $190 + 74 = 264$ $264 \div 100 = 2.64m$</p> |
| Q15) | <p>$1M \rightarrow 3p$ $5m \rightarrow 3 \times 5 = 15$ $15 + 11 = 26$ $\frac{3}{4} \times \frac{2}{3} = \frac{1}{2}$</p> <p>$2u = 26$ $1u = 26 \div 2 = 13$ $3u = 13 \times 3 = 39$ $39 \div 3 = 13$ $13 + 5 = 18$</p> |
| Q16) | <p>a) $20 \div 2 = 10$ $\frac{1}{2} \times 3.14 \times 10 \times 10 = 157$ $10 \div 2 = 5$ $3.14 \times 5 \times 5 = 78.5$ $100 - 78.5 = 21.5$ $21.5 + 157 = 178.5 \text{ cm}^2$</p> <p>b) $\frac{1}{2} \times 3.14 \times 20 = 31.4$ $3.14 \times 10 = 31.4$ $31.4 + 10 + 31.4 = 72.8cm$</p> |
| Q17) | a) $3 : 16$ |

| |
|--------------|
| <p>b)112</p> |
|--------------|

| |
|---|
| <p>c) $112 - 24 - 24 = 64$</p> |
|---|

| |
|---------------------------------------|
| <p>$64 \times 5 = 320$</p> |
|---------------------------------------|

| |
|------------------------------------|
| <p>$320 + 64 = 384$</p> |
|------------------------------------|

