



PEI HWA PRESBYTERIAN PRIMARY SCHOOL  
PRELIMINARY EXAMINATION

PRIMARY 6  
SCIENCE  
(BOOKLET A)

23 AUGUST 2019

Name: \_\_\_\_\_ (    )

Class: \_\_\_\_\_

Total time for Booklets A and B: 1 h 45 min

**INSTRUCTIONS TO CANDIDATES**

1. Write your Name, Class and Register No. in the spaces provided above.
2. DO NOT turn over this page until you are told to do so.
3. Follow all instructions carefully.
4. Answer all questions.
5. Shade your answers on the Optical Answer Sheet (OAS) provided.

This booklet consists of 19 printed pages, excluding the cover page.

For each question from 1 to 28, four options are given. One of them is the correct answer. Make your choice (1, 2, 3 or 4) and shade your answer on the Optical Answer Sheet. (56 marks)

1 The diagram below shows a flowchart of three organisms, Q, R and S.

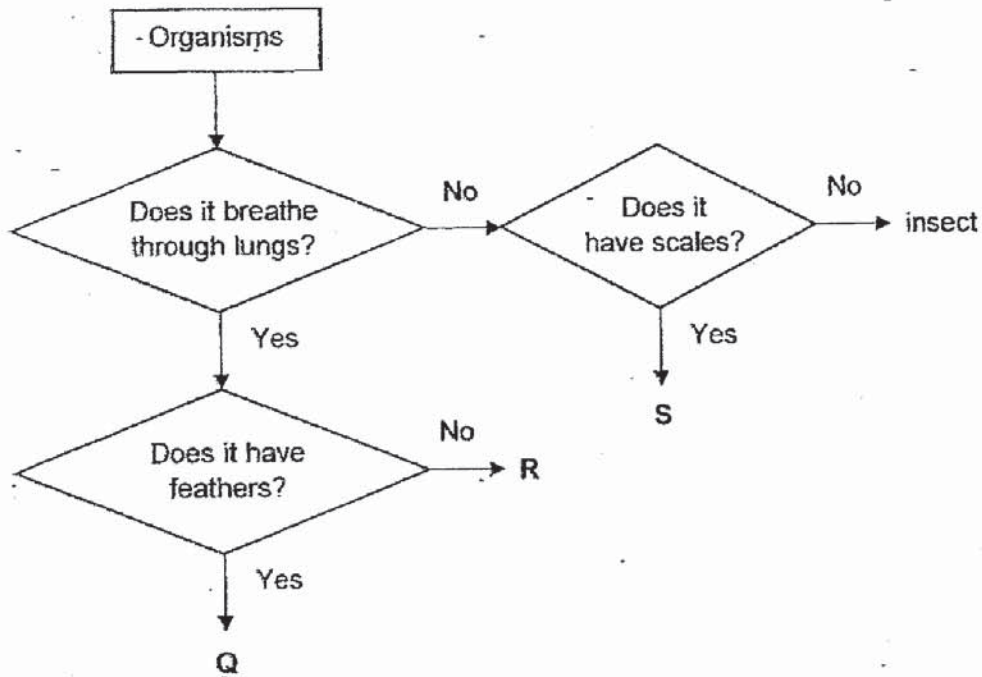

Based on the flowchart above, which of the following most likely represents organisms Q, R and S?

	Q	R	S
(1)	bird	mammal	fish
(2)	fish	amphibian	reptile
(3)	mammal	reptile	fish
(4)	bird	fish	reptile

2 The table below shows the properties of four materials, A, B, C and D.

Property	Material			
	A	B	C	D
Flexible	No	Yes	No	Yes
Waterproof	Yes	Yes	No	No

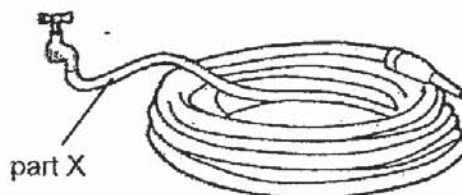

Which material is most suitable for making part X of the water hose?

- (1) A
- (2) B
- (3) C
- (4) D

3 The diagram below shows a rib cage of a human. One of its function is to provide protection to organs S and T.

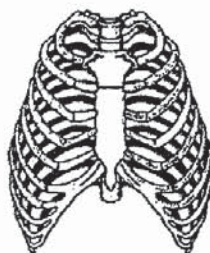

rib cage

Which organ system does organs S and T belong to?

	Organ S	Organ T
(1)	digestive	muscular
(2)	respiratory	skeletal
(3)	circulatory	respiratory
(4)	circulatory	skeletal

4 Devi set up the experiment as shown below.

The capacity of the sealed glass jar is  $300 \text{ cm}^3$ . Each time she pumped the air pump completely,  $50 \text{ cm}^3$  of air would enter the jar. She continued pumping air into the jar until she could no longer pump in any more air.

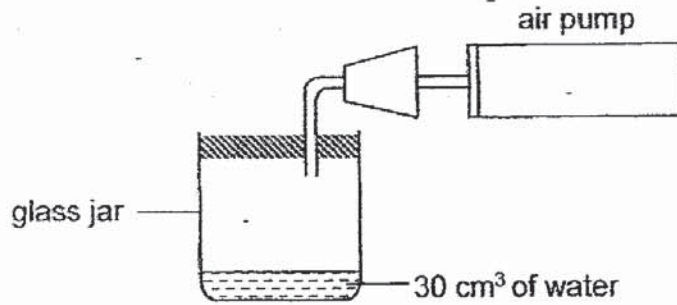

Which one of the following graphs shows the volume of air in the jar after each pump?

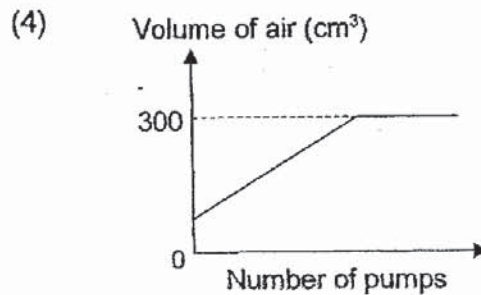
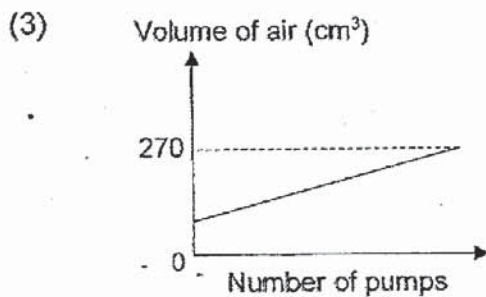
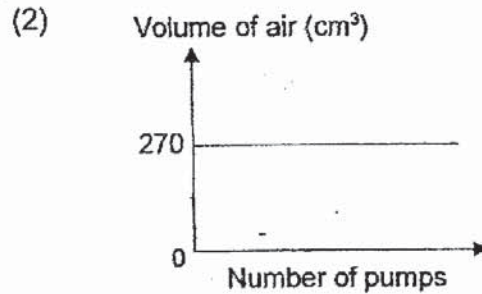
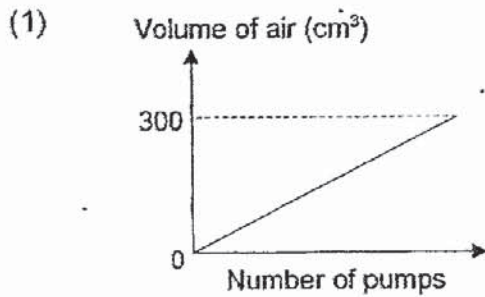

- 5 Peter placed an iron bar, WX, on a piece of styrofoam floating in a basin of water. He hung another iron bar, YZ, with a piece of thread on a retort stand.

The diagram below shows the position of the two iron bars and the compass needle when they came to rest.

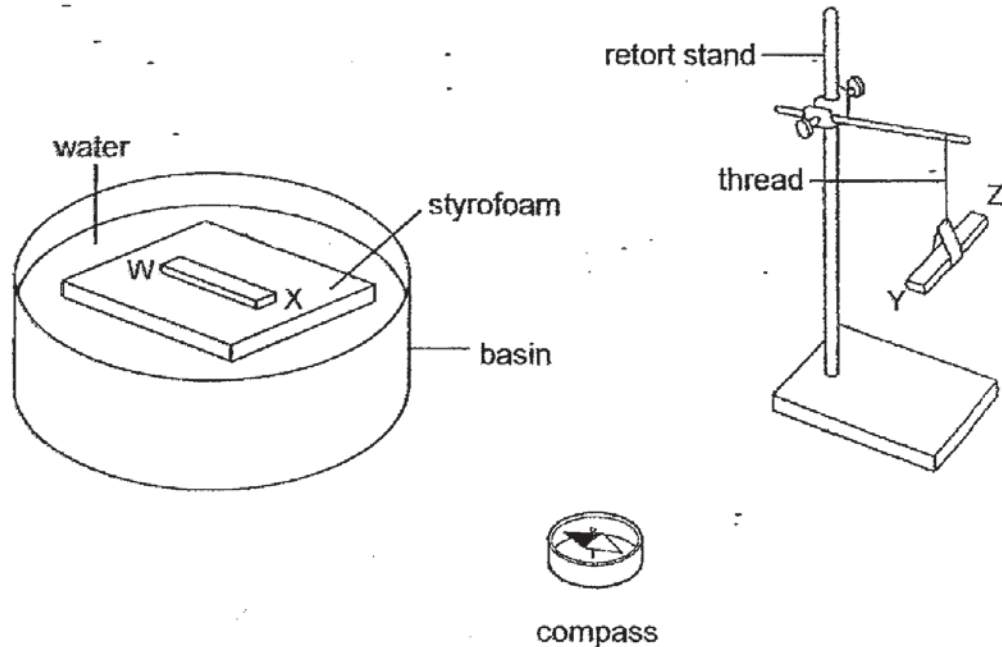

What would Peter most likely observe if he brought bar WX close to bar YZ?

- A End W will repel End Y.
  - B End X will attract End Y.
  - C End W will attract End Z.
  - D Bar WX will not interact with bar YZ.
- 
- (1) D only
  - (2) A and B only
  - (3) A and C only
  - (4) B and C only

- 6 In an experiment, Ayu measured the length of Indah's shadow from a lighted lamp post over a period of time. Her results are shown in the graph below.

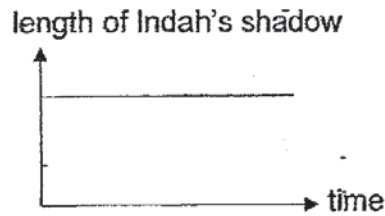

Which of the following statement(s) possibly describes Indah during the experiment?

- A Indah stood still near the lamp post.
- B Indah moved towards the lamp post.
- C Indah moved away from the lamp post.

- (1) A only
- (2) B and C only
- (3) A and C only
- (4) A, B and C

- 7 Zhiming used the set-up below to open the tight metal lid of a glass jar.

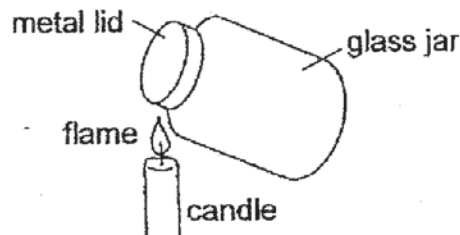

Why was he able to open the metal lid more easily after heating for some time?

- (1) The glass jar contracted.
- (2) The metal lid and the glass jar expanded.
- (3) The metal lid expanded more than the glass jar.
- (4) The air in the glass jar pushed the metal lid open.

- 8 The diagrams below show a flower containing nectar and two birds, S and T, with different types of beaks.

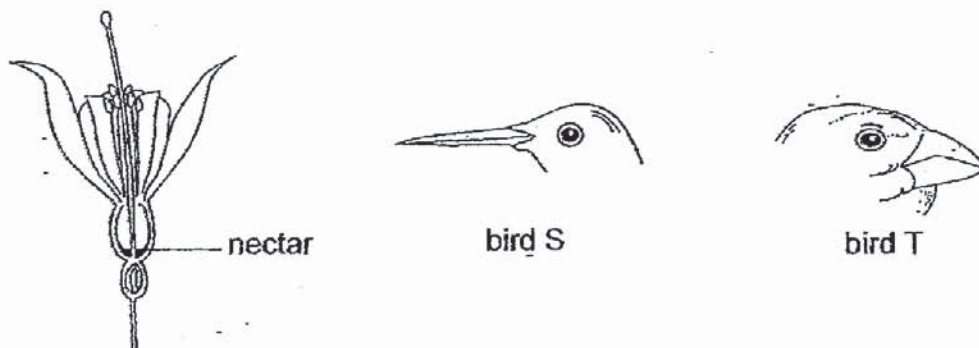

Which bird, S or T, is more likely to feed on the nectar of this flower and how does the flower benefit from the bird?

	Bird	The flower benefits because
(1)	S	the bird disperses pollen grains to another plant.
(2)	S	the nectar is a source of food for the bird.
(3)	T	the bird disperses pollen grains to another plant.
(4)	T	the nectar is a source of food for the bird.

- 9 Matthew rubbed his wet hands under a hand-dryer which produces hot air as shown in the diagram below.

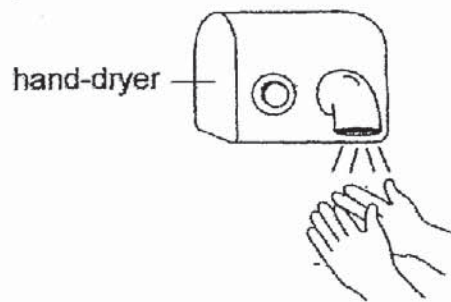

Which one of the following best explains why the water on his hands disappeared after a while?

- (1) The water boiled.
- (2) The water evaporated.
- (3) The water was absorbed by the hand.
- (4) The water vapour in the hot air condensed on his hand.

10 Which of the following statements about breathing are true?

- A Oxygen is the only gas that we breathe in.
- B Breathing takes place all the time when we are alive.
- C A faster breathing rate during an exercise allows more oxygen to enter our blood stream.
- D The air that we breathe in has more carbon dioxide than the air that we breathe out.

- (1) A and B only
- (2) B and C only
- (3) C and D only
- (4) B, C and D only

11 Kim removed an outer ring of a stem from a plant, as shown below. As a result, the tubes carrying food and water were removed.

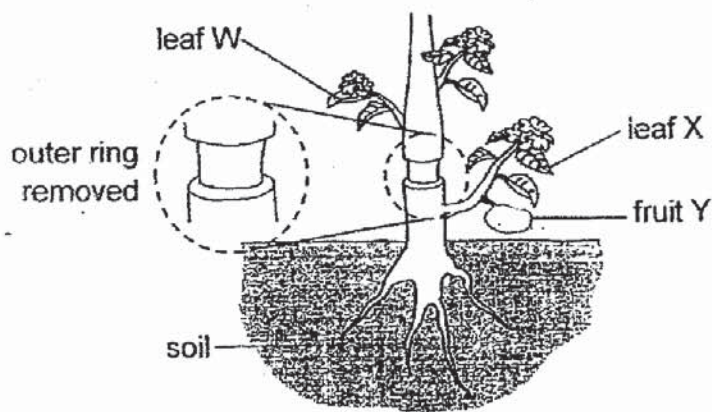

After a week, Kim recorded her observations of leaf W, leaf X and fruit Y.

Which one of the following shows Kim's observations?

	leaf W	leaf X	fruit Y
(1)	remained healthy	wilted	grew smaller
(2)	remained healthy	wilted	grew bigger
(3)	wilted	remained healthy	grew bigger
(4)	wilted	remained healthy	grew smaller



12 Kylo has a toy sword that works on batteries.

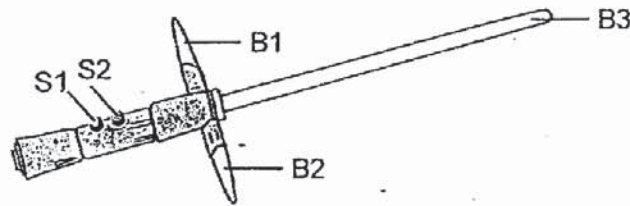

His observations are shown below.

switches		Do the bulbs light up?		
S1	S2	B1	B2	B3
closed	closed	yes	yes	yes
open	closed	yes	yes	no
closed	open	no	no	yes

Which one of the following is a possible circuit in the toy sword?

(1)

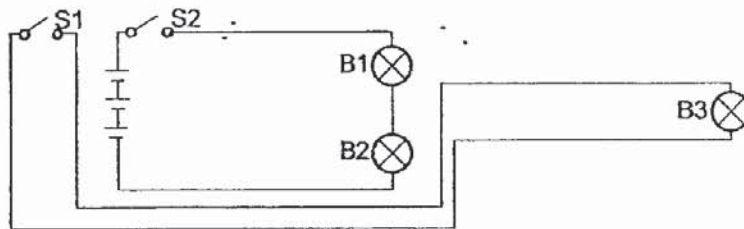

(2)

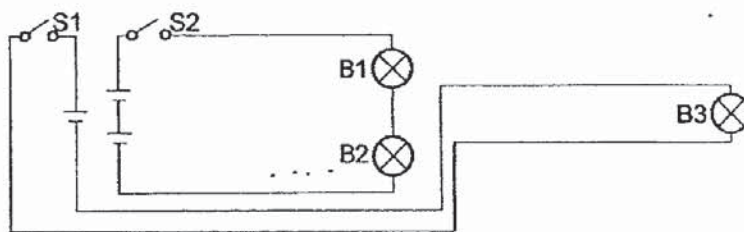

(3)

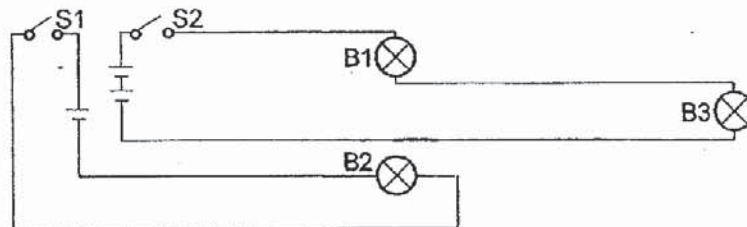

(4)

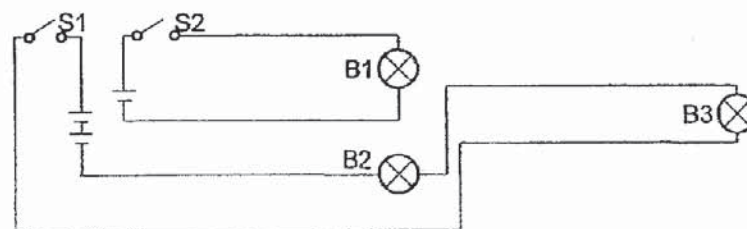

13 Which of the following is produced during photosynthesis?

- (1) carbon dioxide
- (2) food and oxygen
- (3) food and carbon dioxide
- (4) oxygen and carbon dioxide

14 Kerry observed that there was hardly any grass growing on the ground in the area below a tree even though the soil was wet.

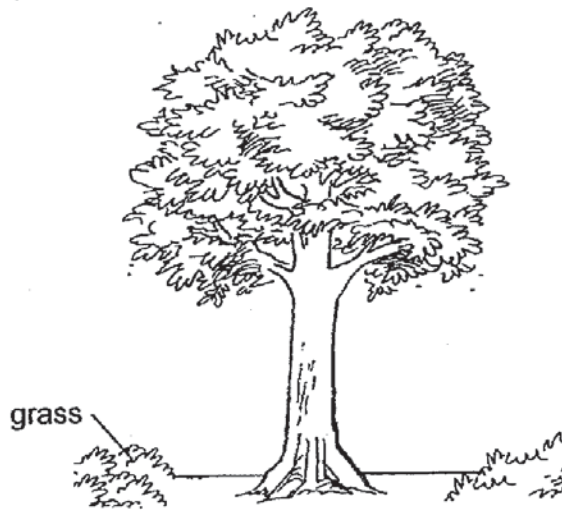

Which of the following best explains his observation?

- (1) There is not enough water for the grass to grow.
- (2) There is not enough oxygen for the grass to grow.
- (3) There is not enough sunlight for the grass to grow.
- (4) There is not enough carbon dioxide for the grass to grow.

15 Minah wanted to investigate how the temperature inside a toy house is affected by the presence of plants. She used the set-up shown below.

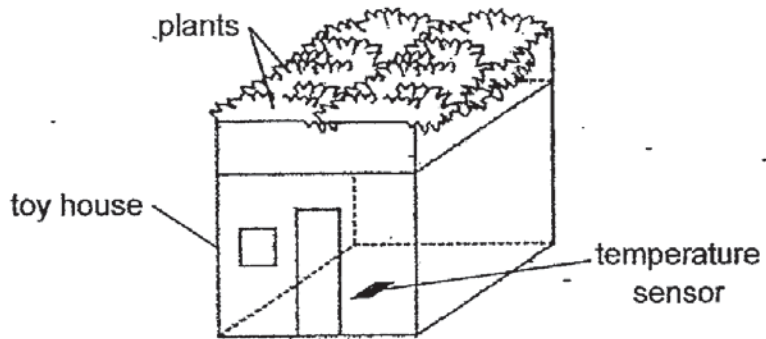

Which one of the following should Minah use as a control for her experiment?

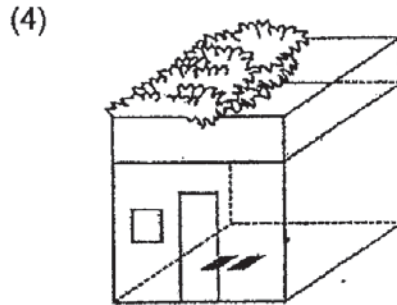
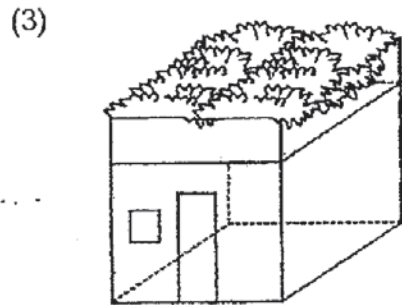
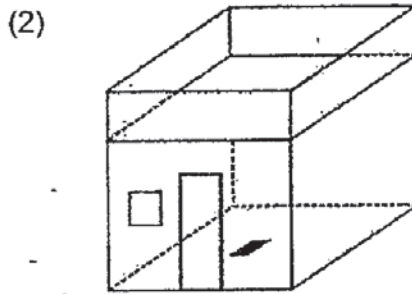
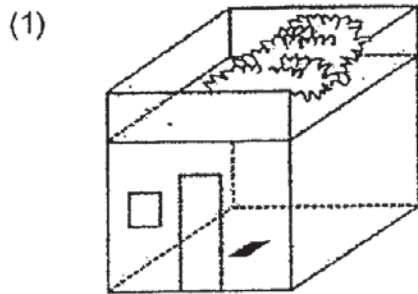

- 16 Study the two set-ups A and B below. At the start, the colour of the substance T was red. When the amount of carbon dioxide increases, substance T will change to yellow. When the amount of carbon dioxide decreases, substance T will change to purple.

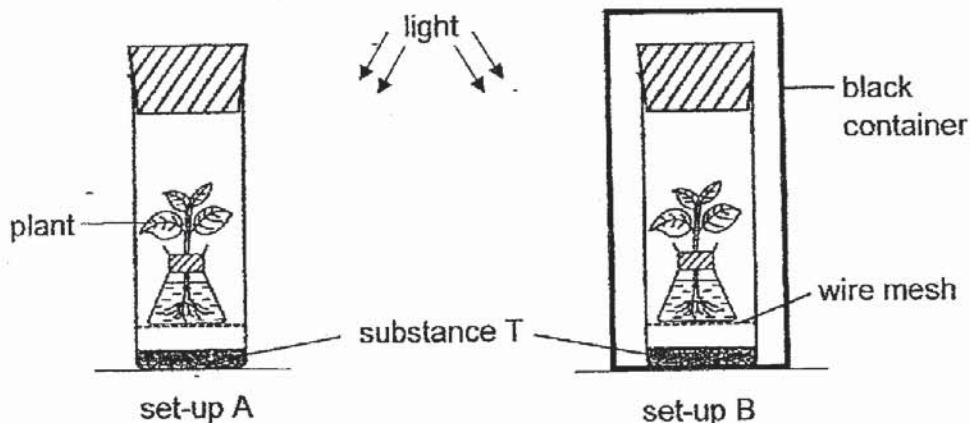

What is the colour of substance T in each set-up after 6 hours?

	set-up A	set-up B
(1)	red	red
(2)	purple	red
(3)	purple	yellow
(4)	yellow	purple

- 17 Study the circuit below. When the switch was closed, the bulb lit up.

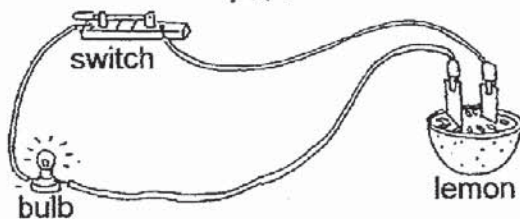

The bulb lit up due to the \_\_\_\_\_ energy in the lemon.

- (1) heat
- (2) kinetic
- (3) potential
- (4) electrical

18 Which of the following correctly describes the energy conversion that takes place during photosynthesis?

- (1) light energy to kinetic energy
- (2) light energy to potential energy
- (3) heat energy to kinetic energy
- (4) heat energy and light energy to potential energy

19 Study the diagram below carefully.

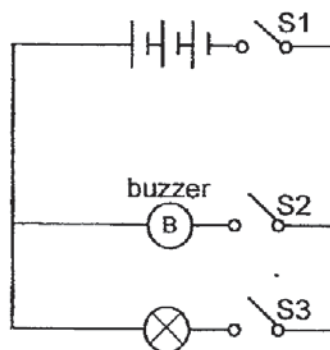

Potential energy  $\rightarrow$  electrical energy  $\rightarrow$  light energy + heat energy

Which of the switches must be closed for the above energy conversion to take place?

- (1) S1 and S2 only
- (2) S1 and S3 only
- (3) S2 and S3 only
- (4) S1, S2 and S3

20

Four identical balls, E, F, G and H were dropped from different heights. The balls landed in a tray of flour placed directly below. Four dents of different depths were created in the flour by the four balls.

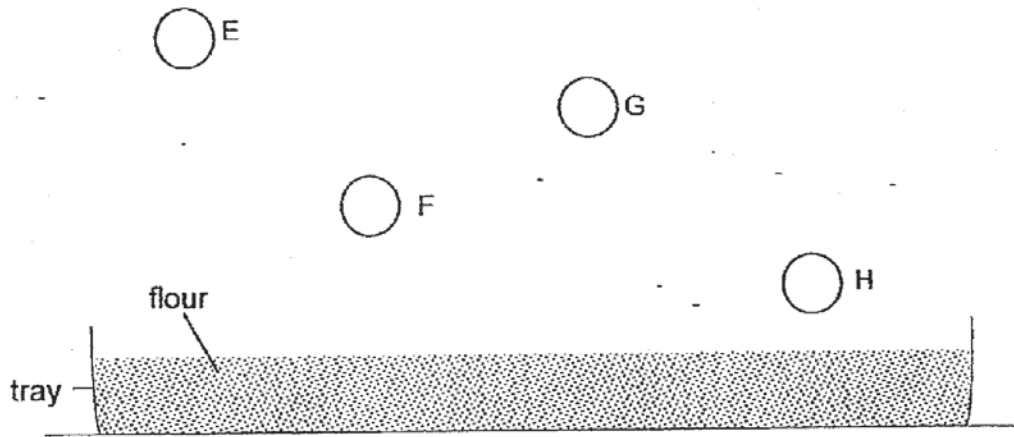

Which one of the following diagrams shows correctly the four dents in the flour?

(1)



(2)



(3)



(4)



21 The diagram below shows four examples of how forces are used.



climbing up a cliff

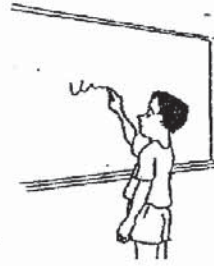

writing on a whiteboard



opening a bottle

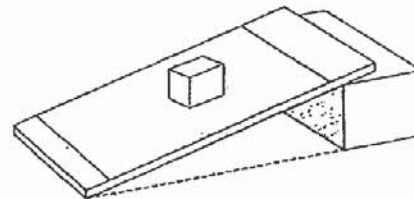

stationary block on a ramp

How many of these examples involve friction?

- (1) 1
- (2) 2
- (3) 3
- (4) 4

22 A fruit drops to the ground because of its \_\_\_\_\_.

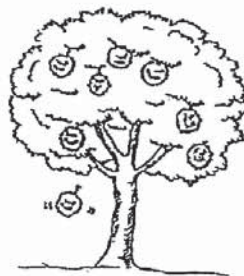

- (1) shape
- (2) speed
- (3) weight
- (4) volume

- 23 In an experiment, three springs, X, Y and Z, had the same original length. Weights were added to all three springs and the results were shown in the line graph below.

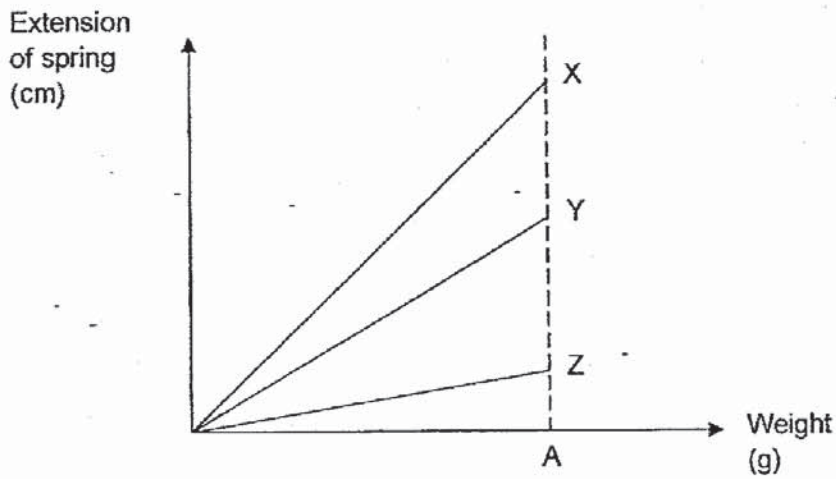

Based on the above graph, which one of the following diagrams correctly shows the lengths of springs, X, Y and Z, at point A?

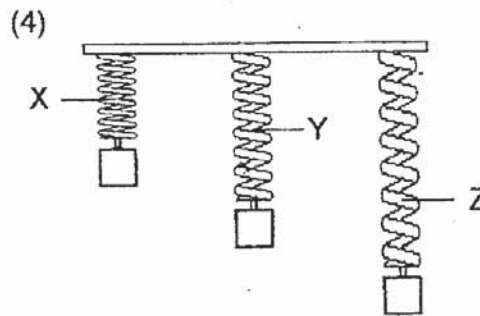
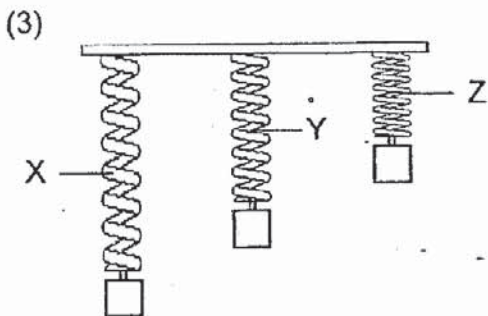
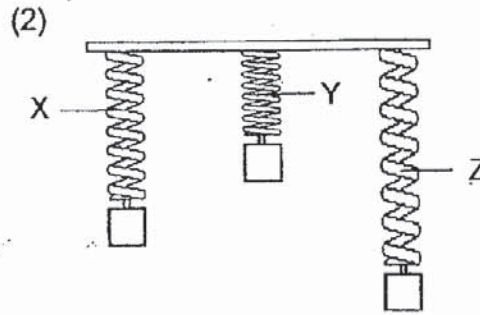
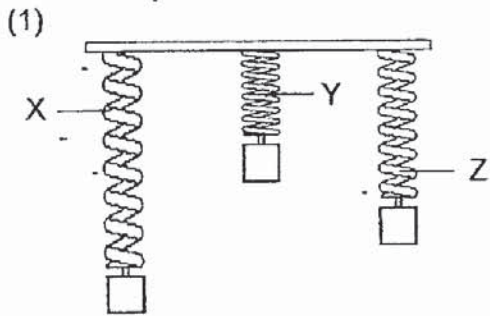



24

Jumat puts a black plastic sheet above a layer of dead leaves around plant R as shown below.

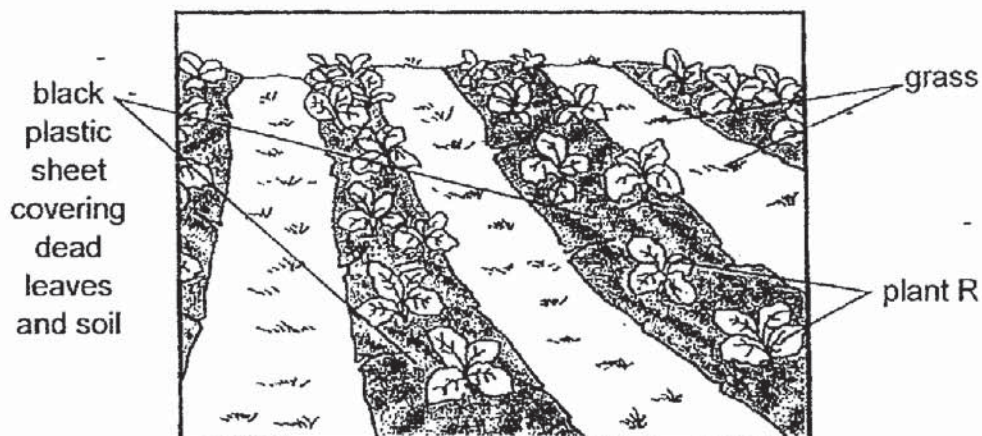

Which of the following statement(s) is/are true about the function of the black plastic sheet?

- A It prevents the dead leaves from decomposing.
- B It slows down the rate of water lost to the surrounding.
- C It absorbs heat from the Sun and keeps the soil warm.

- (1) B only
- (2) C only
- (3) B and C only
- (4) A, B and C

25 Gopal conducted two experiments on food relationships in a community consisting of a plant and three other organisms, P, Q and R.

The table below shows the observations of the experiments conducted over three days.

Experiment	Start of experiment	End of experiment
1	<ul style="list-style-type: none"> <li>leaves from the plant</li> <li>one living organism Q</li> </ul>	<ul style="list-style-type: none"> <li>bits of leaves left</li> <li>one living organism Q</li> </ul>
2	<ul style="list-style-type: none"> <li>one living organism P</li> <li>one living organism Q</li> <li>one living organism R</li> </ul>	<ul style="list-style-type: none"> <li>one living organism R</li> </ul>

Based on the observations above, which of the following possibly shows the food relationship among the plant, organism P, organism Q and organism R?

- (1) plant → Q → P → R
- (2) plant → Q → R → P
- (3) plant → R → Q → P
- (4) plant → P → R → Q

26 Plants A, B and C have adaptations that help them survive.

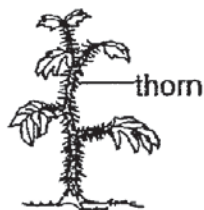

plant A



plant B



plant C

Study the diagrams above and match the plants with the function of its adaptation.

Function	Plant
To keep animals away	(i)
To store water in the leaves	(ii)
Attracts insects for pollination	(iii)

	(i)	(ii)	(iii)
(1)	A	B	C
(2)	A	C	B
(3)	B	C	A
(4)	C	A	B

27 The table below shows how organisms are classified according to their methods of breathing.

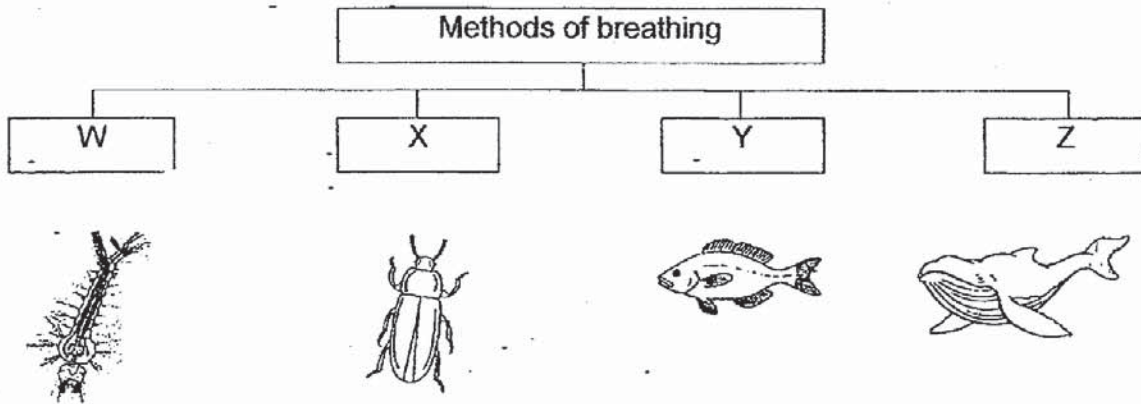

The organism A below moves up to the surface and uses part A to breathe.

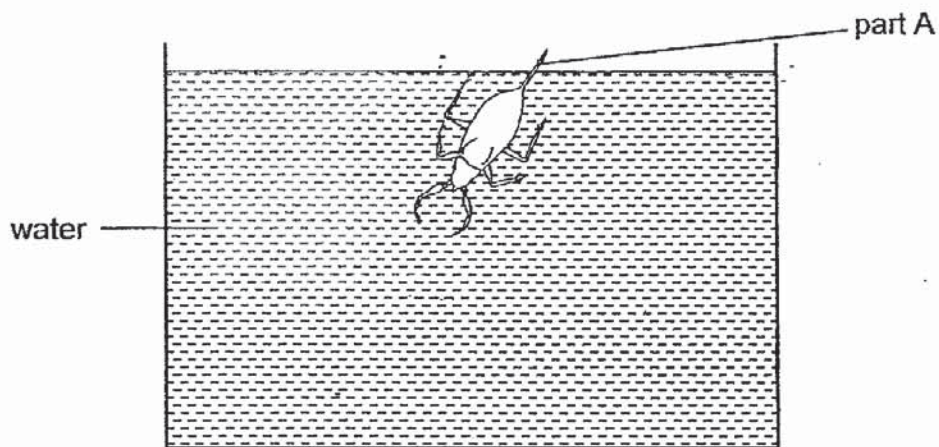

Based on the information above, which group, W, X, Y or Z, does the organism A belong to?

- (1) W
- (2) X
- (3) Y
- (4) Z

28 The diagram below shows part of a small hill.

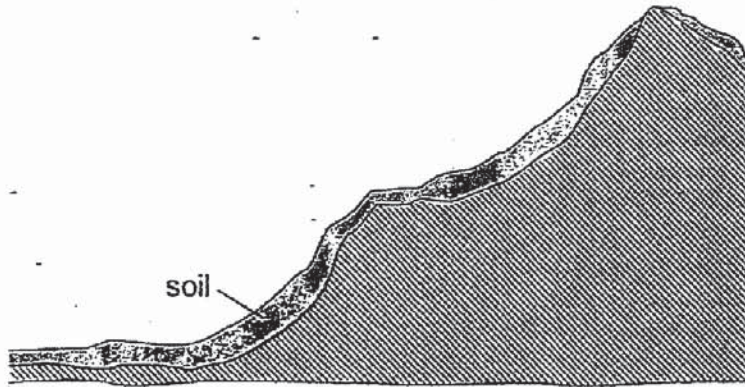

A farmer wanted to grow plants on the hill to prevent soil from being washed down by heavy rain. Which of the following plant(s) should the farmer grow so that the least amount of soil will be washed down?

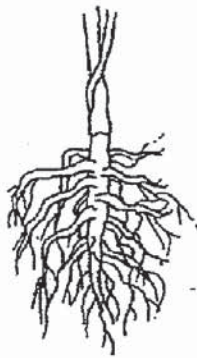

(1)



(2)

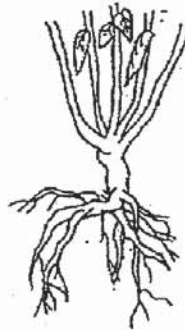

(3)



(4)



PEI HWA PRESBYTERIAN PRIMARY SCHOOL  
PRELIMINARY EXAMINATION

PRIMARY 6  
SCIENCE  
(BOOKLET B)

23 AUGUST 2019

Name: \_\_\_\_\_

Class: \_\_\_\_\_

Parent's Signature

Total time for Booklets A and B: 1 h 45 min

**INSTRUCTIONS TO CANDIDATES**

1. Write your Name, Class and Register No. in the spaces provided above.
2. DO NOT turn over this page until you are told to do so.
3. Follow all instructions carefully.
4. Answer all questions.
5. Write all your answers in this booklet.

Marks (Booklet A) :	<b>56</b>
Marks (Booklet B) :	<b>44</b>
Total Marks (Booklets A & B) :	<b>100</b>

This booklet consists of 15 printed pages, excluding the cover page.

For questions 29 to 41, write your answers in the booklet.  
The number of marks available is shown in brackets [ ] at the end of each question or part question. (44 marks)

- 29 Bacteria A can cause food poisoning when food is stored at temperatures between 5°C and 60°C. The food is still safe to eat if the amount of bacteria A is below the safety limit. Melvin carried out an experiment to find out how fast bacteria A grows at room temperature. His results are shown below.

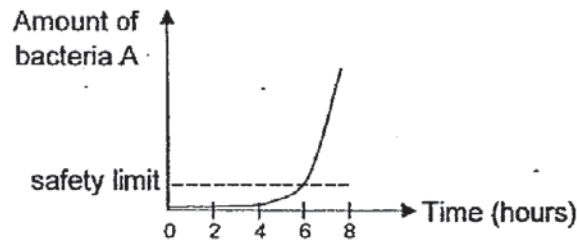

Melvin bought a packed meal that was cooked at a temperature above 60°C. A time-stamp was printed with the information as shown below.

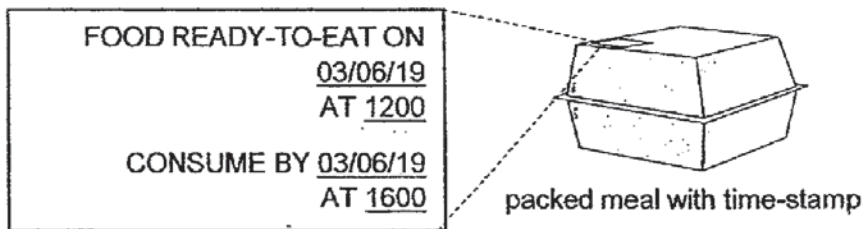

Based on Melvin's experiment and the information above, explain why the cooked food inside the packed meal may no longer be safe to eat after 1800. [2]

---

---

---

30

Jon set up the following experiment to measure the amount of light passing through four materials, A, B, C and D using a tube made of a material that did not allow light to pass through. A light sensor was fixed at one end of the tube and a light source was attached at the other end.

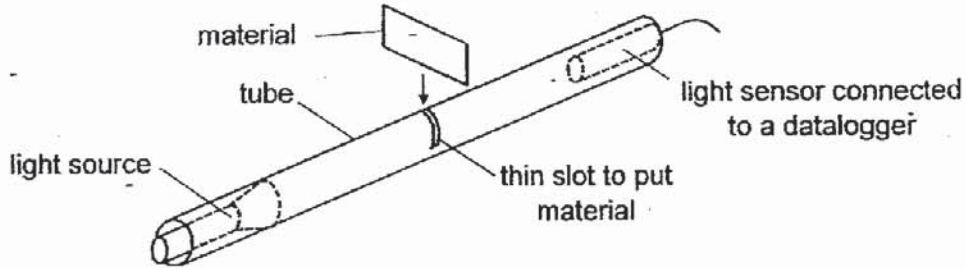

The graph below showed the results of his experiment.

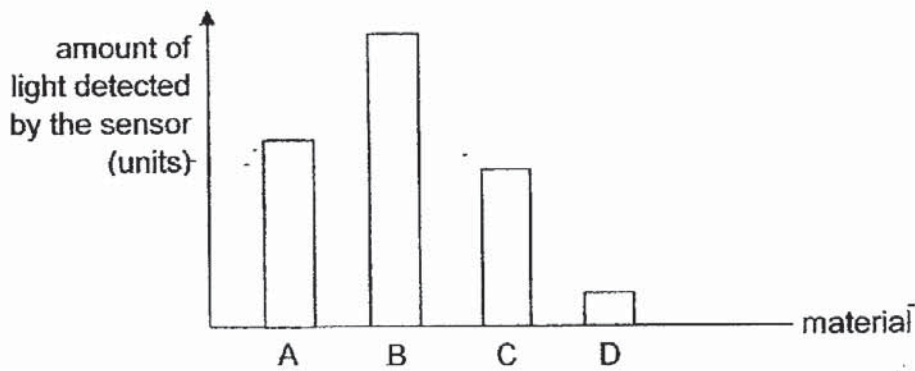

Jon wanted to make curtains to make sure no one could see through his window from the outside.

- (a) Based on his results above, which of the materials, A, B, C or D, is most suitable for making Jon's curtains? Give a reason for your answer. [1]

---

---

- (b) Give a reason why it was unnecessary for Jon to conduct the experiment in a dark room. [1]

---

---

- 31 Anne carried out an experiment in a classroom. She wanted to find out how much volume of water in a beaker would evaporate in 4 hours.

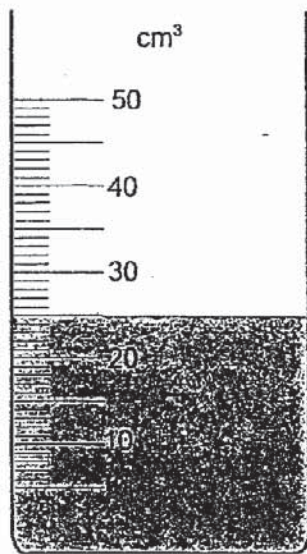

Start of experiment

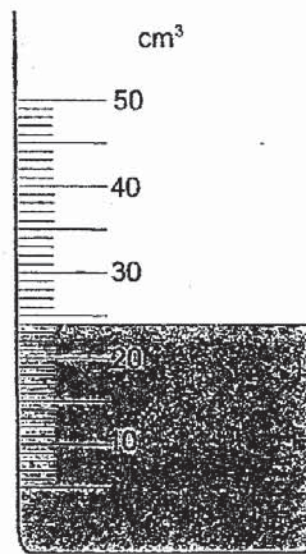

End of experiment

- (a) What is the decrease in volume of water? [1]

\_\_\_\_\_ cm<sup>3</sup>

- (b) Anne repeated the experiment for 1 hour instead of 4 hours. Should this beaker be used if Anne wants to have an accurate reading of the amount of water after 1 hour? Explain why. [2]

---

---

---



- 32 Poh Lee wants to find out where the poles are found on two magnetic strips A and B. He arranged the 2 strips in two different positions as shown in the Diagram 1 and 2.

In Diagram 1, he observed that the top half of strip A attracts only the bottom half of strip B.

In Diagram 2, when he rotated strip A and kept strip B in the same position, both surfaces of each strip attracted each other.

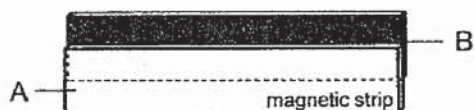

Diagram 1

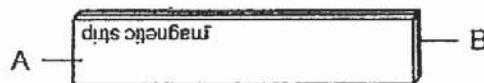
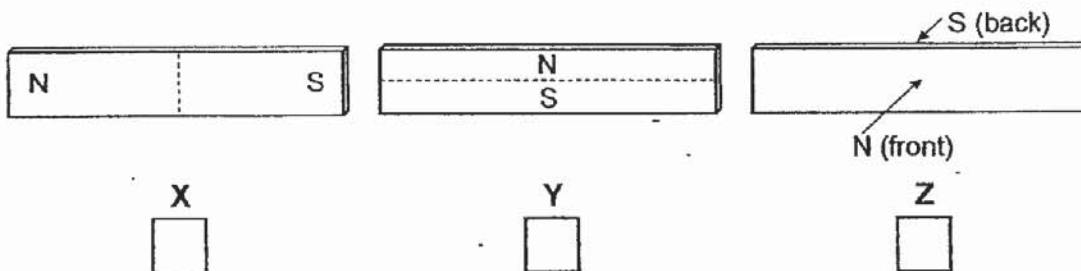

Diagram 2

- (a) Based on the observations above, which of the following diagrams, X, Y or Z, shows the correct poles of the magnetic strip?

Choose your answer by putting a tick (✓) in the box.

[1]



- (b) Poh Lee used identical magnetic strips such as strip A and B to hold a piece of paper onto the whiteboard as shown below.

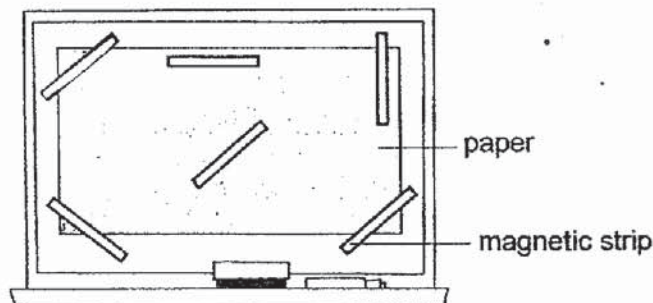

Explain why the whiteboard needs to be a magnetic material but not a magnet for the magnetic strips to hold the paper in place. [2]

---



---

- 33 Benjamin pasted a sticker on a toy car. Some air bubbles were trapped under the sticker as shown in Diagram 1.

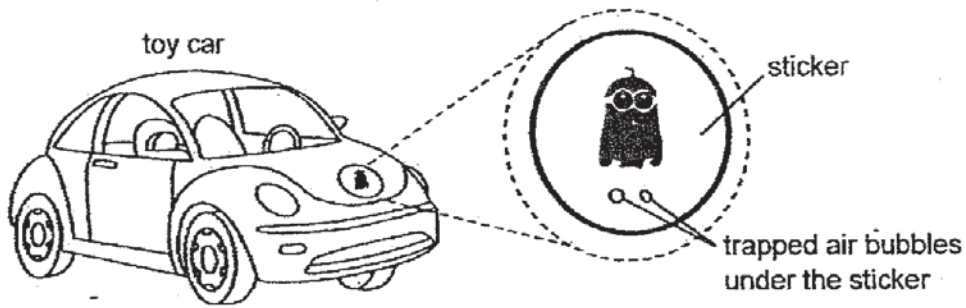

**Diagram 1**

The toy car was left in the sun. After some weeks, the air bubbles became larger as shown in Diagram 2.

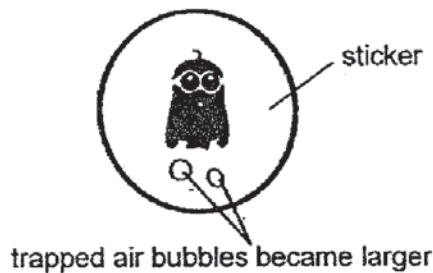

**Diagram 2**

- (a) Put a tick (✓) in the correct boxes to describe the air bubbles in Diagram 2. [2]

		increase	constant	decrease
(i)	The mass of the air bubble.			
(ii)	The volume of the air bubble.			

- (b) Explain why the air bubbles in Diagram 2 became larger. [1]

---



---

- (c) Benjamin suggested putting the toy car inside the refrigerator in order to completely remove the air bubbles trapped under the sticker. Explain why this might not work. [1]

---



---

34 The diagram below shows the steps in making a seed ball used as a reforestation method.

**Step 1:** Mix soil, animal waste, water and seeds.

**Step 2:** Roll the mixture into balls and leave them in the sun to dry before storing.

**Step 3:** Scatter the seed balls onto empty land where new plants need to be grown.

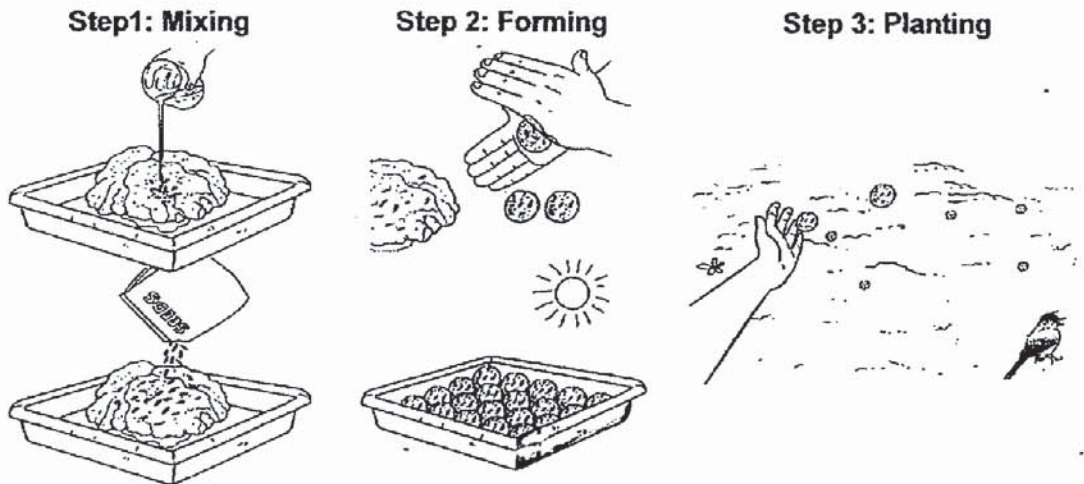

(a) Animal waste is used as a fertiliser to provide nutrients for the plant. Suggest another reason why animal waste is added to the seed ball. [1]

---

---

(b) Based on the steps above, explain why it is important to leave the seed balls in the sun to dry before storing. [1]

---

---

(c) Explain why there should not be too many seeds in each seed ball. [1]

---

---

- 35 An engineer set up a system using alarm A and light bulb B to alert a user when the temperature of an oven is too high. He used a metal rod that expands easily when temperature increases. At 25°C, both alarm A and light bulb B are off. At 100°C, only light bulb B is switched on. At 300°C, both alarm A and light bulb B are switched on.

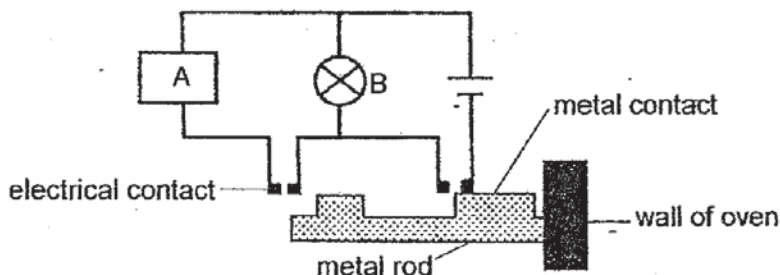

- (a) Explain why both alarm A and light bulb B are switched on when the temperature of the oven is 300°C. [2]

---



---

- (b) The engineer changed parts of the circuit to obtain the results as shown in the table below.

temperature of oven (°C)	yellow bulb	red bulb	alarm A
100	on	off	off
300	on	on	on

The diagram below shows part of the circuit. Complete the circuit so that it will work as described above. Use the symbol  $\textcircled{Y}$  for the yellow bulb,  $\textcircled{R}$  for the red bulb and  $\boxed{A}$  for alarm A. [2]

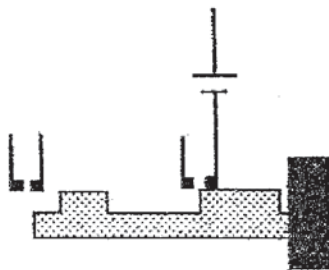

36

Sue conducted an experiment using the set-up below. Both bulbs P and Q were equally bright and placed in identical glass jars.

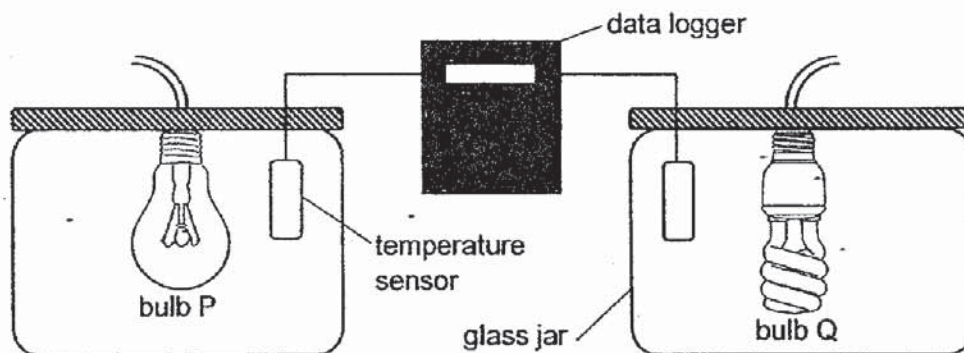

Sue turned on both bulbs and used the temperature sensors and a data logger to record the temperature of the air inside each glass jar.

The results of her experiment are shown below.

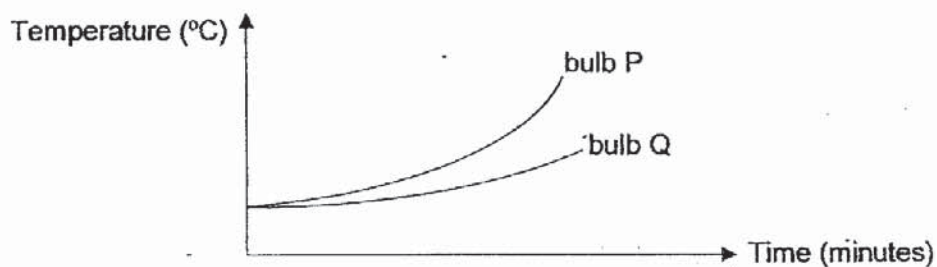

(a) Fill in the boxes to show the energy conversion in the bulb. [1]

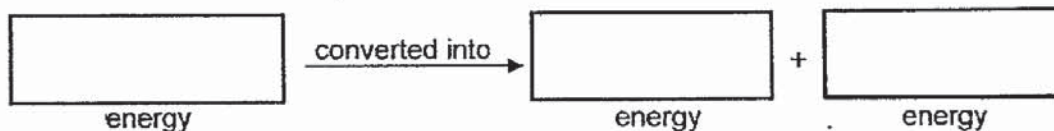

(b) Sue wants to replace the light bulb in her room with a more energy-saving one. Based on the results of Sue's experiment, which of the two bulbs, P or Q, should she use? Explain your answer. [2]

---

---

37 Joel is having soba noodles which is made from a type of plant.

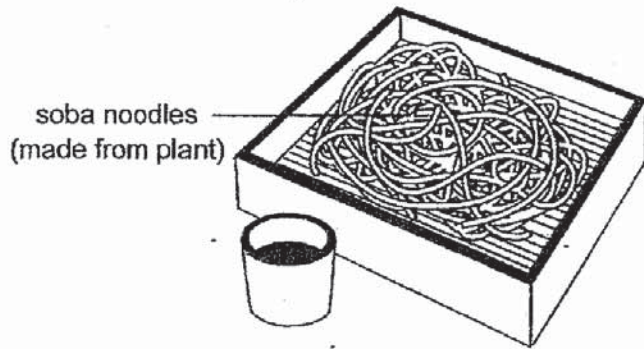

(a) State what Joel can use to test if the soba noodles is made from a plant. [1]

---

(b) Draw a diagram using arrows to show how energy from the Sun is passed on to Joel. [1]

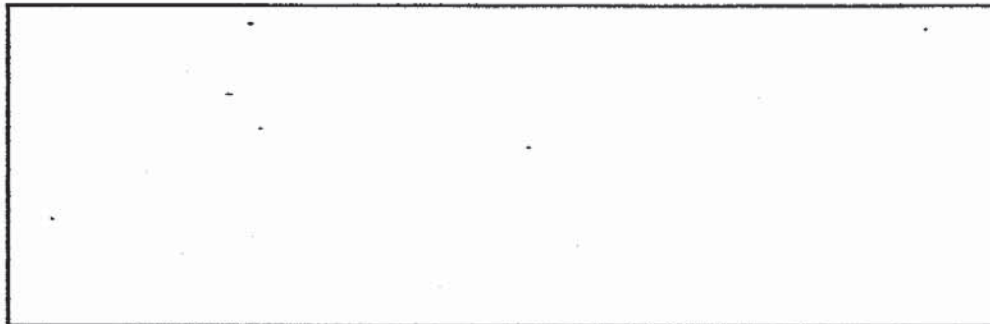

(c) Give a reason why Joel does not get all the energy that the plant obtained from the Sun. [1]

---

---

- 38(a) Wen Kang has a button magnet and a steel cup with a hole at the bottom as shown in Diagram 1. He places the button magnet at the bottom on the outside of the cup and pours in different volumes of water.

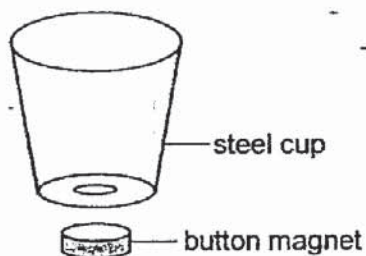

Diagram 1



Diagram 2

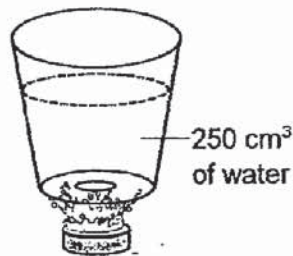

Diagram 3

- (i) The button magnet did not drop when  $50 \text{ cm}^3$  of water was poured into the cup in Diagram 2. Explain why the button magnet did not drop off. [1]

---

---

- (ii) The button magnet dropped when  $250 \text{ cm}^3$  of water was poured into the cup in Diagram 3. Explain, in terms of forces, why the button magnet dropped. [1]

---

---

Question 38 continues on page 11

(b) The diagrams below show a system that fills a plastic cup with liquid from the bottom up.

<b>Diagram 1</b>	The plastic cup with a hole surrounded by a steel ring.
<b>Diagram 2</b>	A button magnet that seals the hole from above before it is placed on the dispenser.
<b>Diagram 3</b>	The cup is pushed down and part X separates the button magnet from the steel ring of the cup. Liquid flows into the cup from holes of the dispenser. Once filled, the cup is lifted upwards and the button magnet returns to its position as shown in Diagram 2.

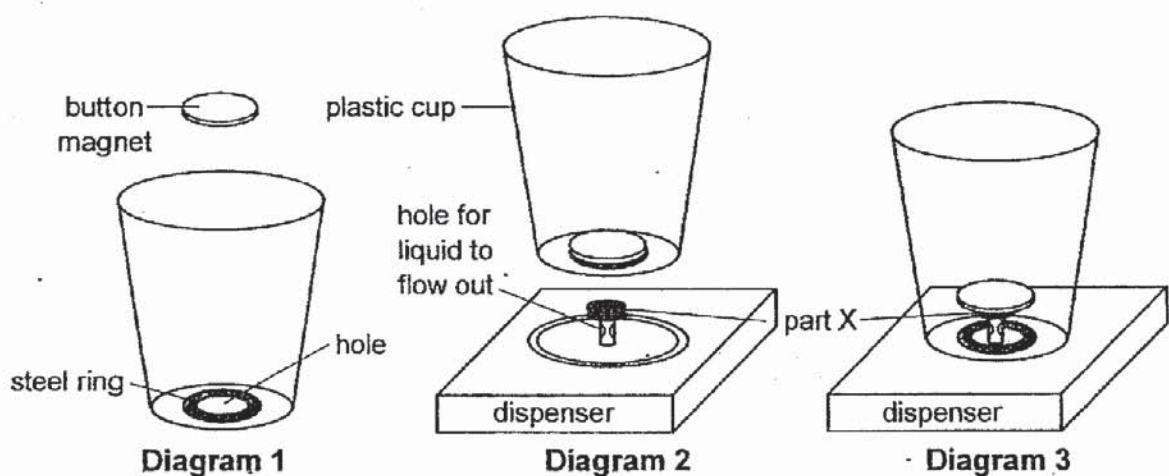

(i) Name the force(s) acting on the button magnet in Diagram 2. [1]

\_\_\_\_\_

(ii) Suggest a material for part X to ensure that the button magnet remain at its position above the steel ring when the plastic cup is filled and lifted. Explain your answer. [2]

**Material for part X:** \_\_\_\_\_

**Reason:**

\_\_\_\_\_  
 \_\_\_\_\_  
 \_\_\_\_\_



39

A, B, C, D and E are 5 organisms in a community.  
Information about these organisms is given in the box below.

A eats E and C.  
B is eaten by E.  
D is eaten by B and C.  
D is a food producer.

- (a) Use the information above to help you complete the food web below. Write the correct letter A, B, C, D or E in each circle. [2]

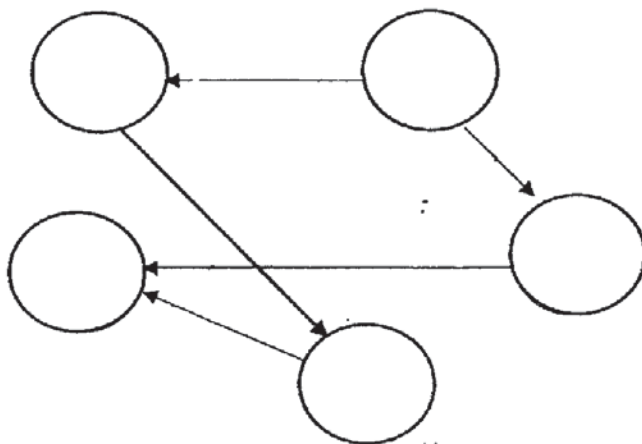

- (b) Based on the food web above, name an organism which is both a predator and a prey. [1]

---

- (c) If all organism C dies and the population of B remains constant, explain what will happen to the population of organism E. [2]

---

---

40

The diagram below shows organism H. Organism H clings onto human hair and feeds on human blood. Organism H do not have wings.

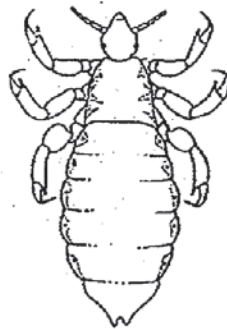

- (a) Dinesh classified organism H as an insect. Give a reason why. [1]

---

- (b) Based on the diagram above, describe one adaptation of organism H that enables it to cling onto human hair. [1]

---

---

Organism H lays eggs. The egg case is stuck to the hair as shown below.

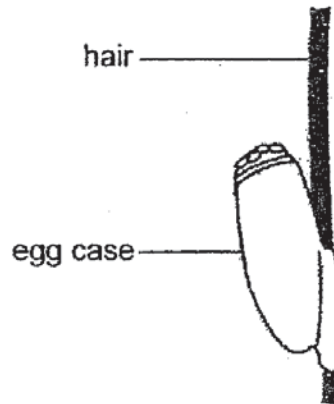

- (c) Give a reason why it is an advantage for organism H to lay eggs on human hair. [1]

---

---

41 Waste is burnt in the incinerator plant before sending to landfills for burying. The bar graph below shows how burning waste affects the volume of the waste.

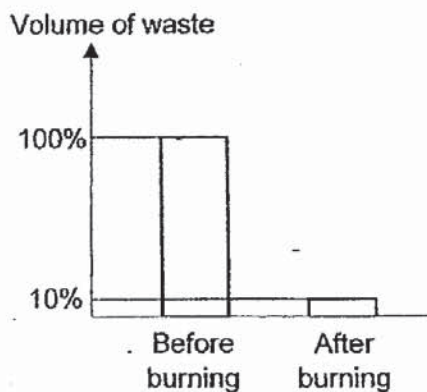

(a) Based on the information above, explain why waste is burnt before sending to landfills for burying. [2]

---



---

A liner is laid down before the waste is dumped into the landfill as shown below.

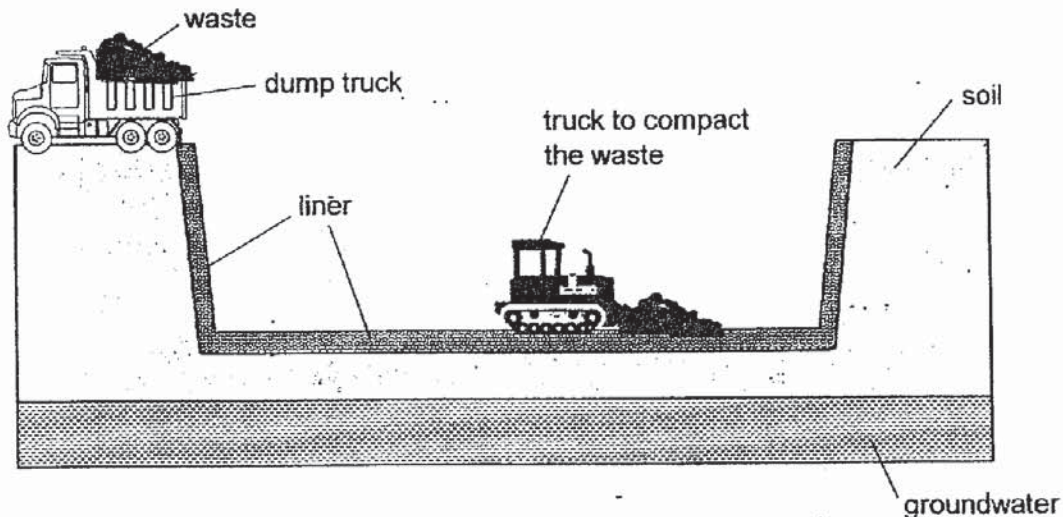

(b) How does the liner in the landfill help protect the environment? [1]

---



---

Question 41 continues on page 15

(c) How does burning large amounts of wastes harm the environment? [1]

---

---

**End of Paper**



# ANSWER KEY

**YEAR : 2019**  
**LEVEL : PRIMARY 6**  
**SCHOOL : PEI HWA PRIMARY SCHOOL**  
**SUBJECT : SCIENCE**  
**TERM : SA2**

## BOOKLET A

Q1	Q2	Q3	Q4	Q5	Q6	Q7	Q8	Q9	Q10
1	2	3	2	4	1	3	1	2	2
Q11	Q12	Q13	Q14	Q15	Q16	Q17	Q18	Q19	Q20
3	2	2	3	2	3	3	2	2	1
Q21	Q22	Q23	Q24	Q25	Q26	Q27	Q28		
4	3	3	3	1	2	1	1		

## BOOKLET B

**Q29** The temperature will fall to room temperature where bacteria A can reproduce. After 6 hours, the amount of bacteria A grows beyond the safety limit, making the food unsafe to eat.

- Q30** (a) Material D. The amount of light detected by the sensor when D was tested is the lowest.  
 (b) The tube prevent other possible sources of light from affecting the results.

- Q31** (a)  $1 \text{ cm}^3$   
 (b) No. Anne should use other beaker which has smaller unit indicator. Because there is no indications on the beaker to show units smaller than  $1 \text{ cm}^3$  therefore the reading would not be accurate.

- Q32** (a) Y  
 (b) With a vial, both poles of the magnetic strip will be attracted to the paper in place. But with a magnet, the magnetic strip will not be held in place.

	increase	constant	decrease
(i) The mass of the air bubble.		/	
(ii) The volume of the air bubble.	/		

- Q33** (a)  
 (b) The air in the bubble gained heat and expanded over time, and its volume in the air bubble increased, so the air bubbles in Diagram 2 became larger.  
 (c) The air bubbles will contract when it loses heat, but the air bubbles will still remain trapped under the sticker.

- Q34 (a) The smell of animal waste could scare animals such as birds away from the seed ball and decreases the chances of the seeds being eaten.
- (b) As water was added in making the seed ball, it is important to prevent the seeds from germinating when stored.
- (c) There might be overcrowding and competition for mineral salts, water, sunlight and space between the plants after germination.
- Q35 (a) The metal rod gain heat to  $300^{\circ}\text{C}$  and the metal contact touches the left-most electrical contact so both A and B because metal rod would conduct electricity.

(b)

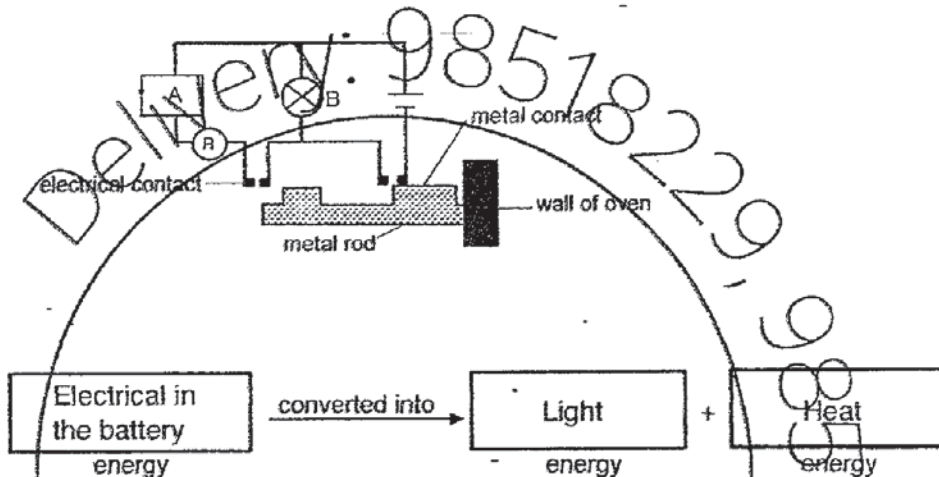

- Q36 (a)
- (b) The temperature rise of bulb Q is lower than bulb P shows that lesser heat is generated by bulb Q by bulb P. This means that lesser electrical energy is converted to heat energy in bulb Q.

- Q37 (a) He should conduct a starch test on the soba noodles.
- (b) The sun  $\rightarrow$  Plant  $\rightarrow$  food
- (c) the  $\rightarrow$  the energy obtained from the sun for its daily activity photosynthesis.

Q38 The force was greater than gravitational force of the water so the

the magnet did not drop off.

- (a)(i) The gravitation force of the water was greater than magnetic force of the button magnet. So, the water could push the magnet away from steel cup.
- (b)(i) Magnetic force and gravitational force.
- (b)(ii) Iron. Part X must be made of a magnetic material so that the magnet will attract part X and prevent the liquid flowing out from the dispenser from pushing the magnet away.

Q39 (a)

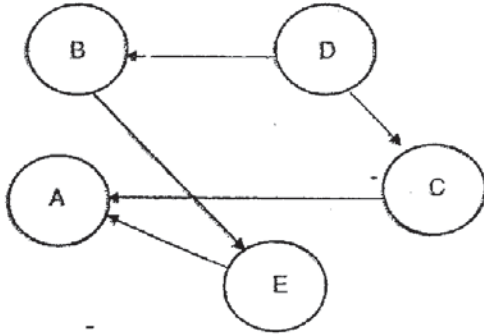

- (b) Organism E.  
(c) The organism in population E decreases. As organism A without organism C, Organism A would depend heavily on Organism E for food.

Q40

- (a) It has three parts of legs.  
(b) Its legs could easily grasp on human hair as it has claws.  
(c) The young of organism H could feed on human blood right after it comes out of its egg case.

Q41

- (a) It reduces the volume of the waste significantly and could store more trash in each landfill, saving space, and slows the rate of filling the landfill.  
(b) The liner prevents waste seeping into the water  
(c) It causes air pollution which could result in acid rain, haze, et cetera and which most effects are harming health of living thing.



