

Anglo-Chinese School (Junior)



PRELIMINARY EXAMINATION (2025)

PRIMARY 6 MATHEMATICS PAPER 1 (Booklet A)

18 August 2025

Total Time for Booklets A and Booklet B : 1 hour

Name: _____ Class: 6 _____

INSTRUCTIONS TO CANDIDATES

1. Write your index number in the boxes at the top right-hand corner.
2. Do not turn over this page until you are told to do so.
3. Follow all instructions carefully.
4. Answer all questions.
5. Use a 2B pencil to shade your answers on the Optical Answer Sheet (OAS).
6. The use of calculators is **NOT** allowed.

This booklet consists of 8 printed pages.

Questions 1 to 10 carry 1 mark each. Questions 11 to 15 carry 2 marks each.
For each question, four options are given. One of them is the correct answer.
Make your choice (1, 2, 3 or 4) and shade your answer on the Optical Answer Sheet.
(20 marks)

1 Which of the following is fifty thousand and fifty-six in numerals?

- (1) 5056
- (2) 50 056
- (3) 500 056
- (4) 5 000 056

2 Which decimal is greater than 0.07 but smaller than 0.19?

- (1) 0.1
- (2) 0.2
- (3) 0.01
- (4) 0.06

3 In the number line, what is the mixed number represented by A?

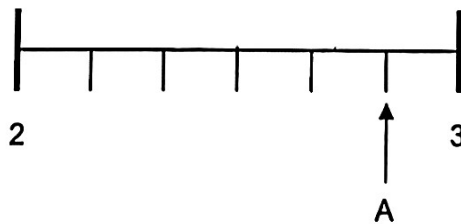

- (1) $2\frac{2}{3}$
- (2) $2\frac{5}{6}$
- (3) $2\frac{6}{7}$
- (4) $2\frac{7}{8}$

4 What is the value of $18 + (30 - 6) \div 3 \times 2$?

- (1) 7
- (2) 22
- (3) 34
- (4) 52

5 The figure shows part of a weighing scale. Which of the following is the closest to the reading indicated by the arrow?

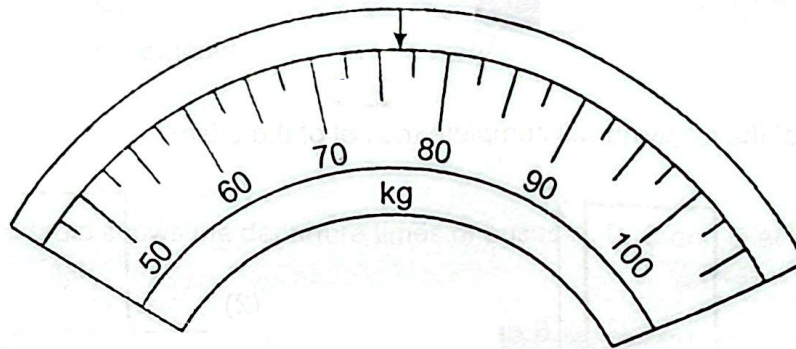

- (1) 73
- (2) 75
- (3) 77
- (4) 78

6 Which of the following is the same as 6020 ml ?

- (1) 60 l 2 ml
- (2) 60 l 20 ml
- (3) 6 l 2 ml
- (4) 6 l 20 ml

- 7 A prism has two right-angled triangular faces and three rectangular faces.

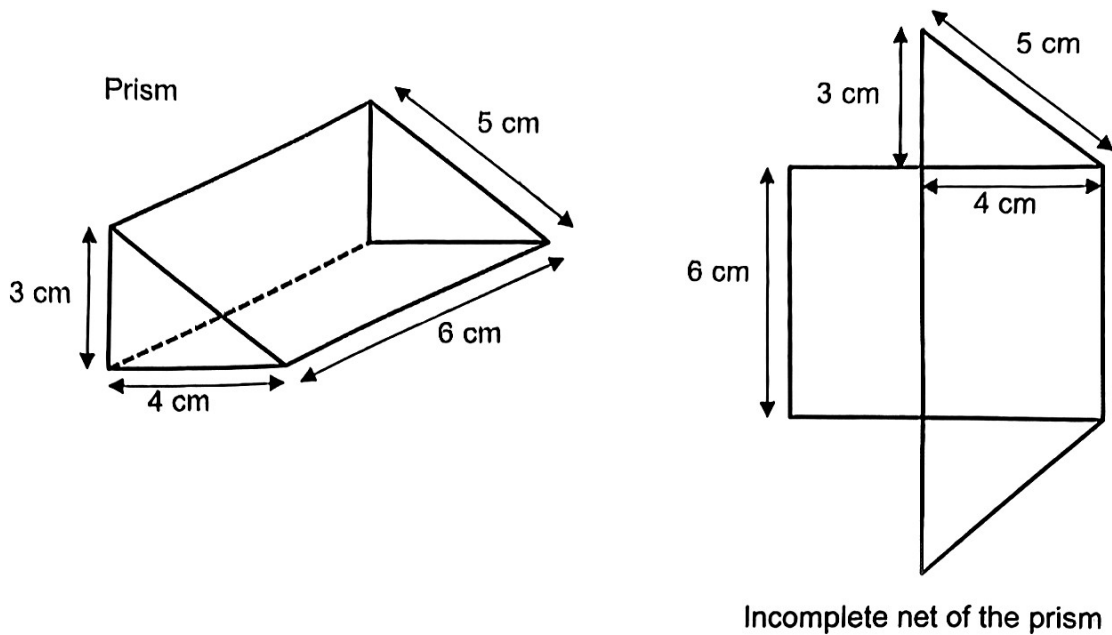

Which of the following will complete the net of the prism?

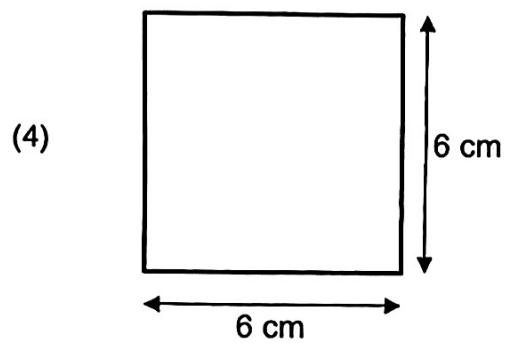
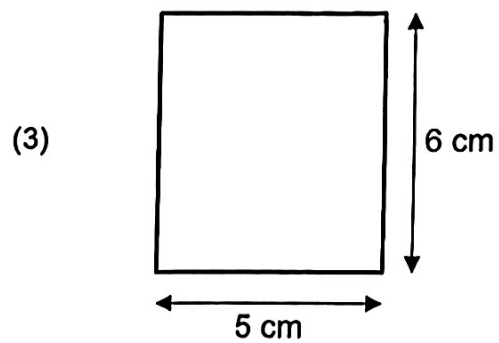
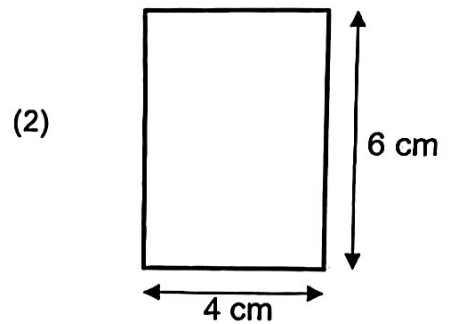
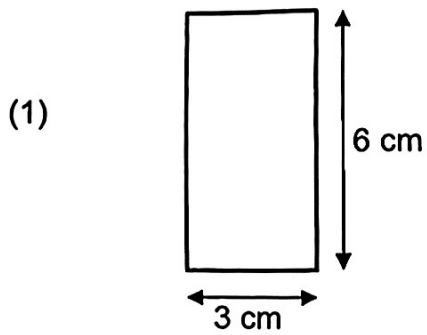

- 8 Five letters are drawn on the square grid.

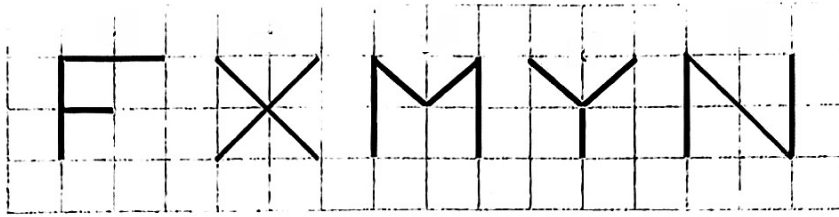

How many of the letters have both perpendicular and parallel lines?

- (1) 5
 (2) 2
 (3) 3
 (4) 4
- 9 The table shows the departure times of buses A, B, C and D at the Bus Terminal.

Bus	Departure Time
A	1245
B	1330
C	1415
D	1500

Keith arrived at the Bus Terminal at 1 p.m. Which is the earliest bus he can take?

- (1) A
 (2) B
 (3) C
 (4) D

- 10 The number of pies sold at a bakery decreased by 150 from Wednesday to Thursday and increased by 60 from Thursday to Friday.

Which graph shows the number of pies sold at the bakery from Wednesday to Friday?

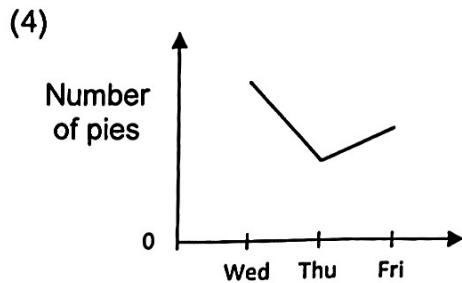
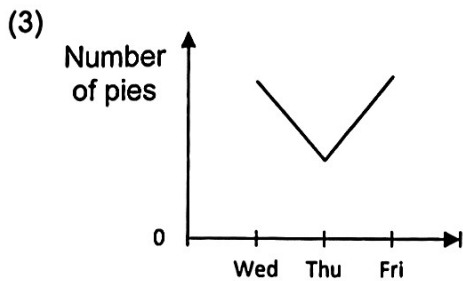
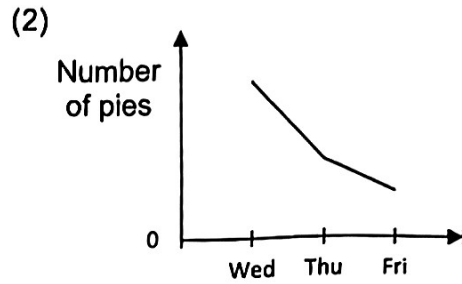
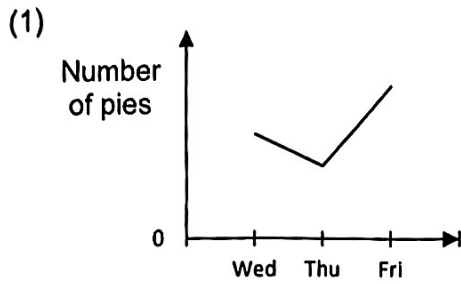

- 11 A plank of wood was first cut into two pieces in the ratio 2 : 3. The longer piece was then cut into 2 pieces in the ratio 1 : 3. The shortest piece of wood among the three pieces was 18 cm long. What was the length of the original plank of wood?

- (1) 72 cm
- (2) 90 cm
- (3) 108 cm
- (4) 120 cm

- 12 The shaded figure is made up of a large semicircle and a square with a small semicircle cut-out from the square. The diameter of the small semicircle is 10 cm, and the diameter of the large semicircle is twice the length of the diameter of the small semicircle. What is the perimeter of the shaded figure?
(Take $\pi = 3.14$)

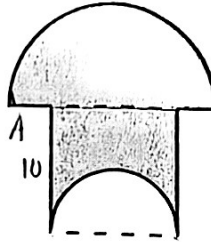

- (1) 77.1 cm
 (2) 71.4 cm
 (3) 67.1 cm
 (4) 61.4 cm
- 13 The table below shows the rates for renting a bicycle at a shop

First hour	\$6
Every additional 30 min or part thereof	\$4

Daniel rented a bicycle at 8.20 a.m. What is the latest time Daniel must return his bicycle if he only has \$20 to spend on rental fees?

- (1) 10.20 a.m.
 (2) 10.50 a.m.
 (3) 11.20 a.m.
 (4) 11.50 a.m.

- 14 Two figures PQRS and WXYZ are shown in the square grid below.

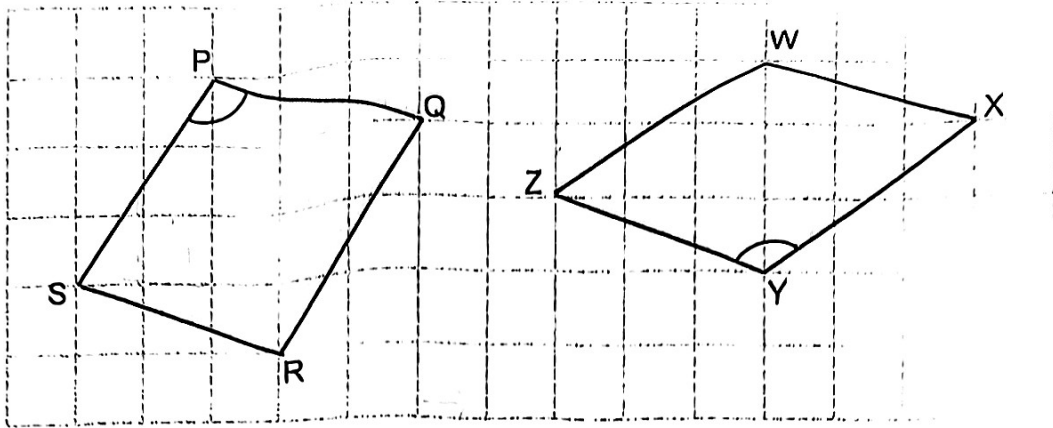

Which of the following statement(s) is/are true?

- A. $SR \parallel WX$
 B. $\angle SPQ = \angle XYZ$
 C. Figure PQRS and Figure WXYZ has the same perimeter.
- (1) A only
 (2) A and B only
 (3) A and C only
 (4) All the above
- 15 Mollie had a container full of flour. Nellie and Ollie each had $\frac{2}{7}$ of what Mollie had. Mollie gave away some flour to Nellie and Ollie so that all 3 of them have the same amount of flour in the end. What fraction of flour did Mollie give away?

- (1) $\frac{5}{7}$
 (2) $\frac{5}{14}$
 (3) $\frac{5}{21}$
 (4) $\frac{10}{21}$

Anglo-Chinese School (Junior)



PRELIMINARY EXAMINATION (2025)

PRIMARY 6 MATHEMATICS PAPER 1 (Booklet B)

18 August 2025

Total Time for Booklets A and Booklet B : 1 hour

Name: _____ Class: 6. _____

INSTRUCTIONS TO CANDIDATES

1. Do not turn over this page until you are told to do so.
2. Follow all instructions carefully.
3. Answer all questions.
4. Use a dark blue or black ballpoint pen to write your answers in the space provided for each question.
5. The use of calculators is **NOT** allowed.
6. Do not use correction fluid/tape.
7. Do not use highlighters on any part of your answers.

This question paper consists of 10 printed pages and 1 blank page.

Questions 16 to 20 carry 1 mark each. Write your answers in the spaces provided.
For questions which require units, give your answers to the units stated. (5 marks)

16 Find the value of $4.5 \div 300$.

Ans : _____

17 Find the value of $\frac{3}{8} \times 12$.

Give your answer in its simplest form.

Ans : _____

18 A hairclip is placed next to a ruler.

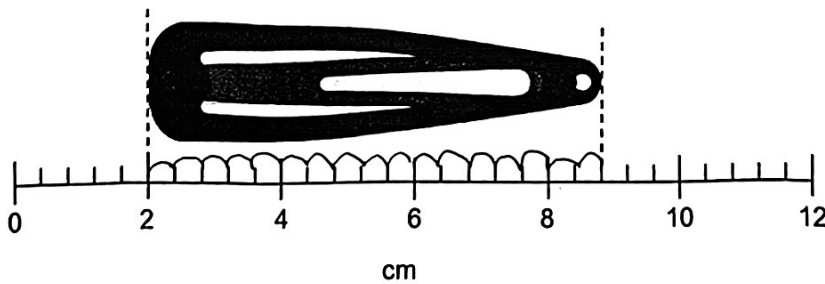

Find the length of the hairclip.

Ans : _____ cm

Sub-Total :

(Go on to the next page)

Please do not write in the margin.

Please do not write in the margin.

19

Benson took 210 min to complete a race. He ~~took~~^{was} 25 min slower than Carson. How long did Carson take to complete the race? Give your answers in min.

Ans : _____ min

20

The figure shows a cuboid with a square base of area 25 cm^2 . The area of the shaded face is 60 cm^2 . What is the height of the cuboid?

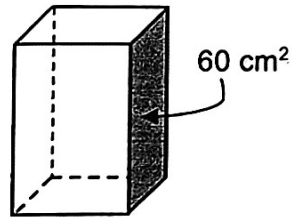

Ans : _____ cm

Please do not write in the margin.

Please do not write in the margin.

Sub-Total :

Questions 21 to 30 carry 2 marks each. Show your working clearly and write your answers in the spaces provided. For questions which requires units, give your answers in the units stated.
(20 marks)

21 Find the value of $6 \div 7$. Round your answer to 2 decimal places.

Ans : _____

22 Jason used a calculator to divide a 4-digit number by a 1-digit number. For the 1-digit number, he made a mistake by pressing 6 instead of 7. He obtained an incorrect answer of 210. What should be the correct answer?

Ans : _____

Please do not write in the margin.

Please do not write in the margin.

Sub-Total :
(Go on to the next page)

- 23 The table shows the number of visitors to Bird Paradise.

Day	Number of visitors to Bird Paradise
Monday to Friday	$3p$ each day
Saturday	$6p + 70$
Sunday	$9p - 25$

- a) What was the total number of visitors to Bird Paradise in the week?
Express your answer in terms of p in the simplest form.

Ans : (a) _____

- b) The total number of visitors to Bird Paradise in the week was 7395. Find the value of p .

Ans : (b) _____

Please do not write in the margin.

Please do not write in the margin.

Sub-Total :

24

The pie chart represents the type of sports the Primary 6 students liked.
The number of students who liked bowling is the same as those who liked cycling.

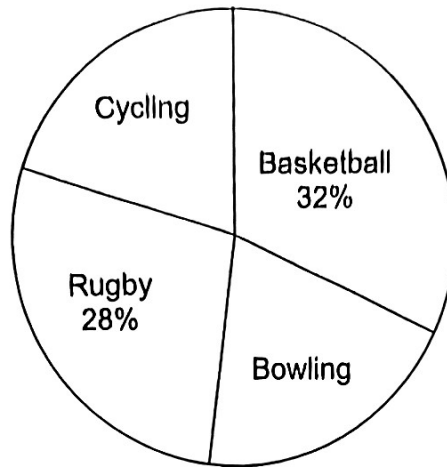

- a) What is the percentage of students who liked bowling?

Ans : (a) _____ %

- b) There were 10 more students who liked basketball than rugby. What was the total number of Primary 6 students?

Ans : (b) _____

Sub-Total :

(Go on to the next page)

Please do not write in the margin.

Please do not write in the margin.

- 25 The figure is made up of squares.
Shade two more squares so that the figure has a line of symmetry. [2m]

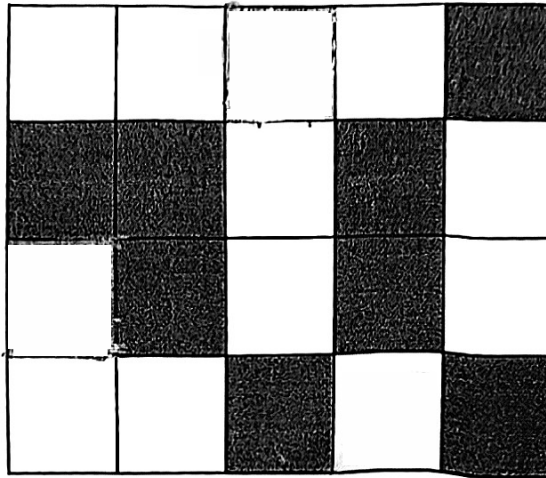

Please do not write in the margin

- 26 The square grid shows the plan of a playground.
The rocking horse is north of the see-saw.

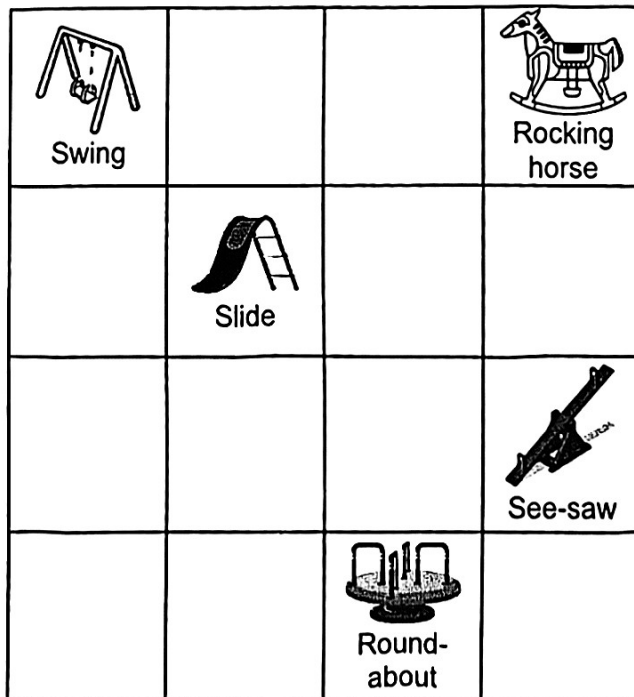

Please do not write in the margin

- (a) In which direction is the rocking horse from the swing?

Ans : (a) _____

- (b) The playground manager wants to place a bench in the playground. The bench is to be placed south of the slide and north-west of the roundabout. Put a cross (X) in the square where the bench should be placed.

Sub-Total :

- 27 The bar graph shows the amount of rainfall each month from Jul to Dec in 2024.

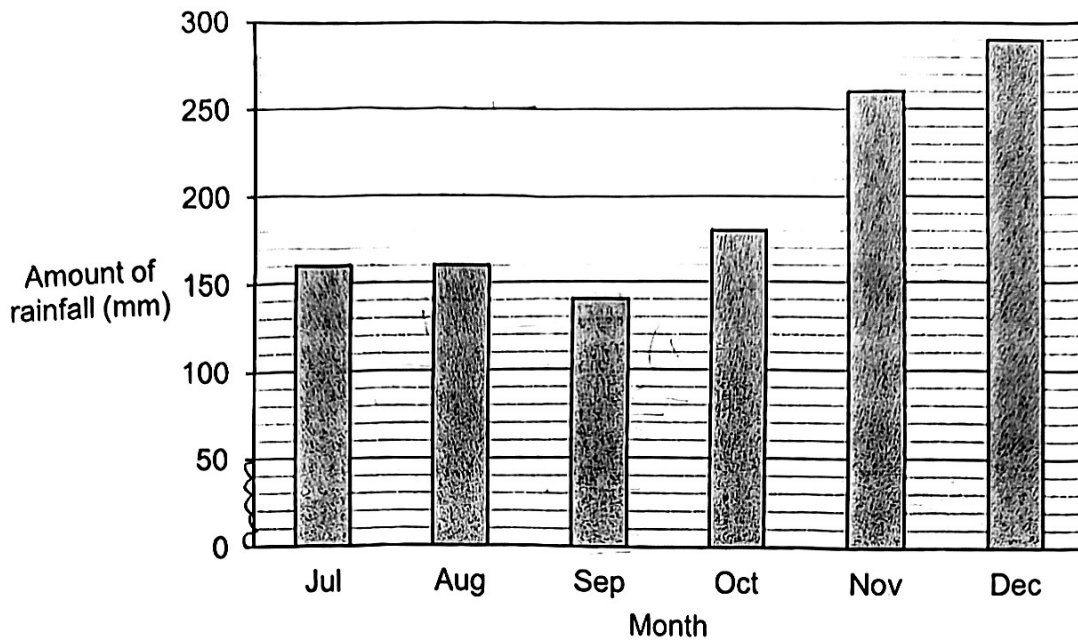

- (a) What is the difference between the highest amount of rainfall in a month and the lowest amount of rainfall in a month?

Ans : (a) _____ mm

- (b) What is the percentage decrease in rainfall in Sep as compared to Aug?

Ans : (b) _____ %

Sub-Total :

(Go on to the next page)

Please do not write in the margin.

Please do not write in the margin.

- 28 During a sale, a store gave a storewide discount of 20%. Darryl signed up as a member and received an additional 10% discount on the discounted price. He paid \$720 for the coffee machine. What was the total amount of his discount?

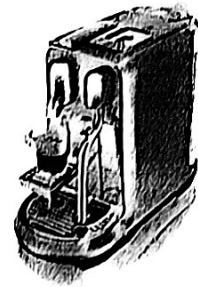

Ans : \$ _____

Please do not write in the margin.

- 29 Nancy had a rectangular piece of paper. She folded along the line AB as shown. $\angle x = 124^\circ$. Find $\angle y$.

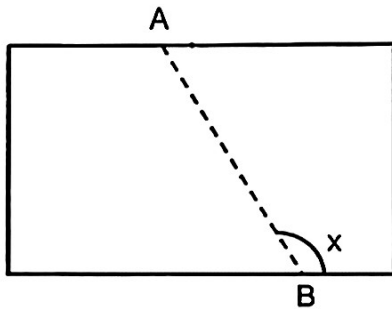

Before folding

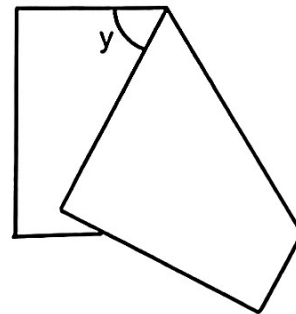

After folding

Ans : _____^o

Please do not write in the margin.

Sub-Total :

- 30 Lisha used 16 identical right-angled triangle tiles to form a rectangle. The perimeter of the rectangle is 80 cm. Find the area of one triangle.

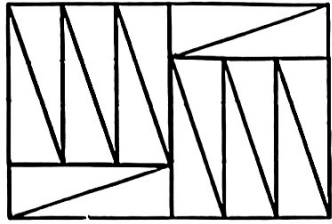

Please do not write in the margin.

Please do not write in the margin.

Ans : _____ cm²

End of Booklet B

Sub-Total :

Anglo-Chinese School (Junior)



PRELIMINARY EXAMINATION (2025)

PRIMARY 6 MATHEMATICS PAPER 2

18 August 2025

Time : 1 hour 30 minutes

Name: _____ Class: 6 _____

Parent's Signature: _____

INSTRUCTIONS TO CANDIDATES

1. Do not turn over this page until you are told to do so.
2. Follow all instructions carefully.
3. Answer all questions.
4. Use a dark blue or black ballpoint pen to write your answers in the space provided for each question.
5. Do not use correction fluid/tape or highlighter.
6. The use of an approved calculator is allowed.

Paper	Booklet	Possible Marks	Marks Obtained
1	A	20	
	B	25	
2		55	
Total		100	

Questions 1 to 5 carry 2 marks each. Show your working clearly and write your answers in the spaces provided. For questions which require units, give your answers in the units stated. (10 marks)

- 1 Samad saves \$2.50 every day. For every \$15 saved, his father will give him an additional \$3. How much money will Samad save in 50 days?

Ans : \$ _____

- 2 Eric gives $\frac{1}{4}$ of his income to his parents. When his income increased by 20%, his parents received \$240 more. What is his income before the increase?

Ans : \$ _____

Please do not write in the margin.

Please do not write in the margin.

Please do not write in the margin.

Sub-Total :

- 3 In the figure, PQRS is a rectangle. RTUV is a rhombus. $\angle RTU = 122^\circ$ and $\angle VRS = 256^\circ$. Find $\angle QRT$.

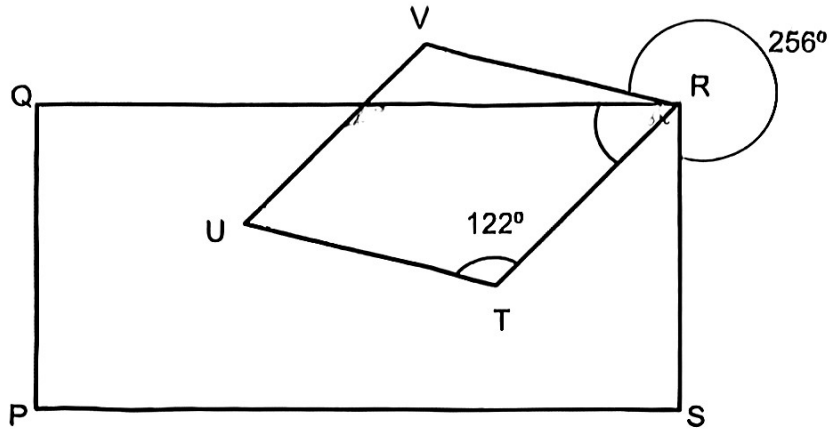

Please do not write in the margin.

Please do not write in the margin.

Ans : _____ °

- 4 The average of four different 2-digit numbers is 92. Of the four numbers, find the smallest possible number?

Ans : _____

Please do not write in the margin.

Sub-Total :

5 The solid below is made up of 8 cubes.

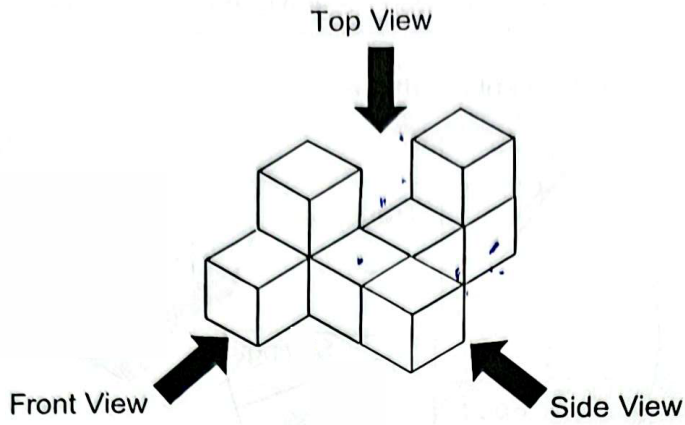

Please do not write in the margin.

Please do not write in the margin.

(a) Draw the front view of the solid on the grid.

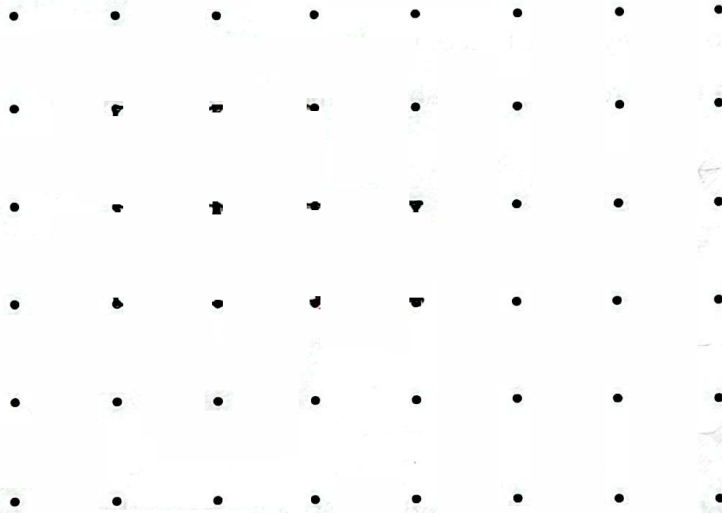

(b) What is the maximum number of cubes that can be added to the solid without changing the front view and side view?

Ans : (b) _____

Please do not write in the margin.

Sub-Total :

Sub-Total :

For questions 6 to 17, show your working clearly and write your answers in the spaces provided. The number of marks available is shown in brackets [] at the end of each question or part-question. (45 marks)

- 6 The pie chart shows how Isabelle spent her money.

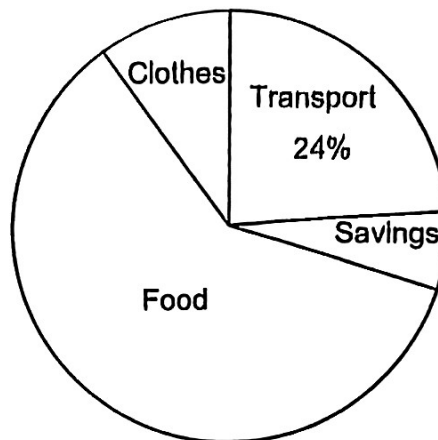

The amount of money Isabelle spent on transport is $\frac{2}{5}$ of the amount she spent on food.

- (a) What is the percentage of Isabelle's money spent on food?

Ans : (a) _____ [1]

The amount of money Isabelle saved is 25% of the amount she spent on transport.

- (b) Isabelle saved \$90. How much money did she spent in total?

Ans : (b) _____ [2]

Please do not write in the margin.

Sub-Total :

Please do not write in the margin.

Please do not write in the margin.

- 7 A rectangular tank measuring 80 cm by 60 cm by 50 cm was $\frac{2}{3}$ full of water. Tap A can fill the empty tank in 8 minutes. How long did it take to fill the tank completely?

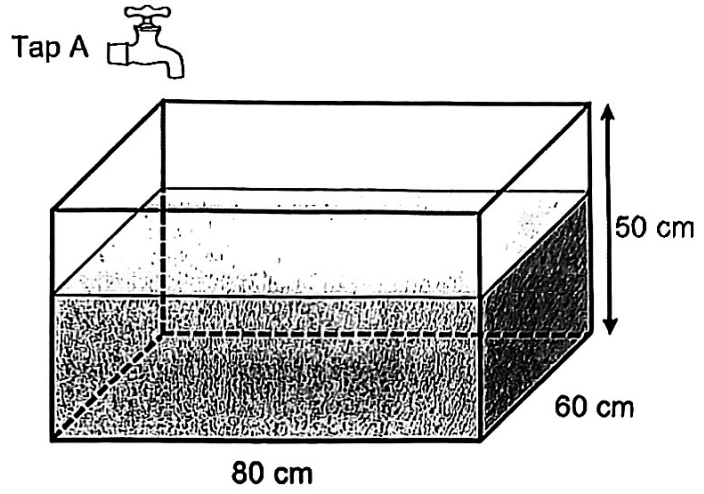

Please do not write in the margin

Please do not write in the margin.

Ans : _____ [3]

Please do not write in the margin.

Sub-Total :

- 8 Frank's mass is y kg. His mass is $\frac{1}{3}$ of Gideon's mass. Henry is 4 kg lighter than Gideon.
- (a) What is the total mass of the 3 boys in terms of y ?

Ans : (a) _____ [1]

- (b) If Frank's mass is 28 kg, what is the difference between Frank's mass and Henry's mass?

Ans : (b) _____ [2]

Please do not write in the margin.

Please do not write in the margin.

9 In the square grid below, ABC is a triangle.

- (a) Measure $\angle ACB$.
- (b) BC form one side of a trapezium BCDE. BC is parallel to DE and $AB = BE$. DE is twice as long as BC. Complete the drawing of trapezium BCDE. [2]

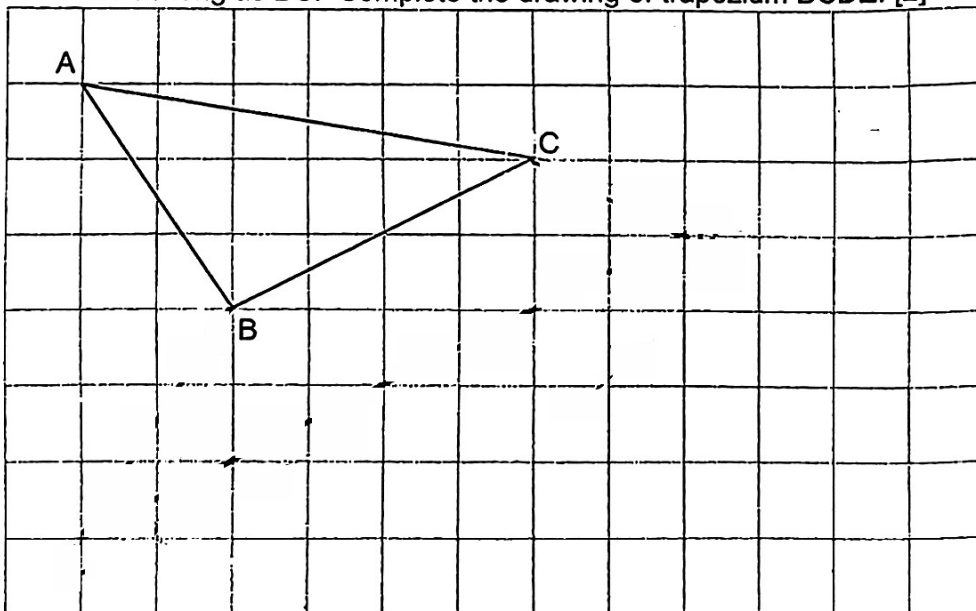

Ans : (a) _____ [1]

Please do not write in the margin.

Sub-Total :

--

10 A shop offered 120 T-shirts at a 20% discount during a 7-day sale. The line graph shows the number of T-shirts left unsold at the end of each day.

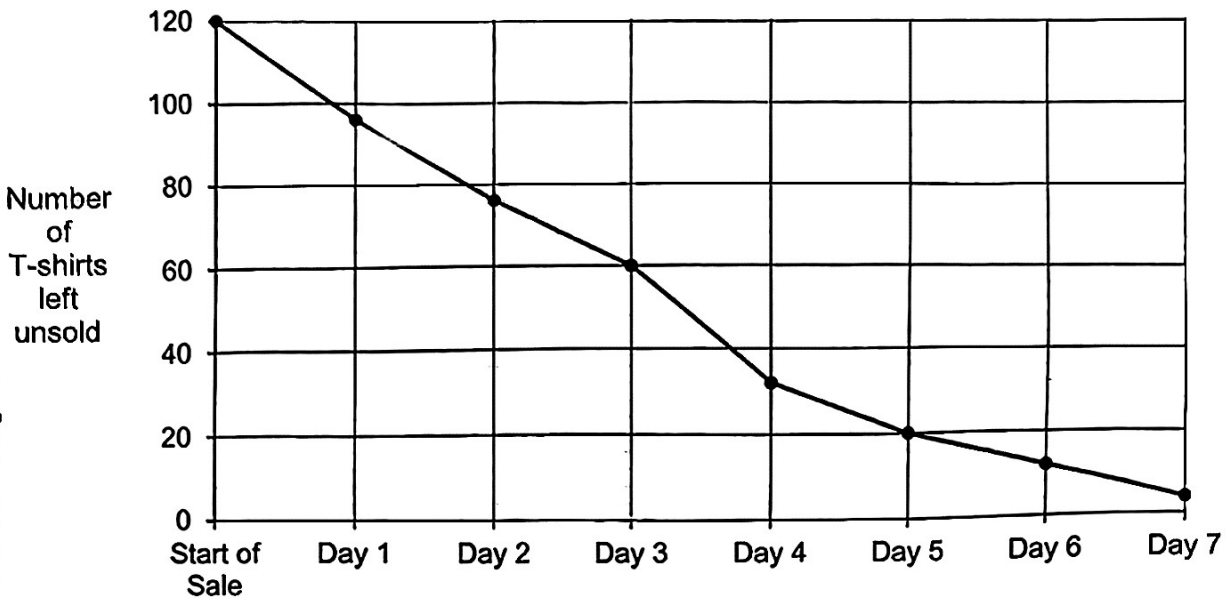

Please do not write in the margin.

Please do not write in the margin.

(a) On which day was the most number of T-shirts sold?

Ans : (a) _____ [1]

(b) What percentage of 120 T-shirts were sold in the first 5 days of the sale? Correct your answer to the nearest percent.

Ans : (b) _____ [1]

(c) The shop collected \$192 on Day 3 of the sale. What was the price of each T-shirts before the discount?

Ans : (c) _____ [2]

Please do not write in the margin.

Sub-Total :

- 11 Ray and Wayne ran in a race around a 400-m track. Ray ran at a speed of 195 m/min and Wayne at a speed that was 25 m/min slower than Ray throughout the race.

(a) How long would it take Ray to run a distance of 350 m more than Wayne?

Ans : (a) _____ [1]

(b) How many **complete** rounds would Ray have finished when the above happened?

Ans : (b) _____ [2]

Please do not write in the margin.

Please do not write in the margin.

Please do not write in the margin.

Sub-Total :

- 12 In the figure, five squares are drawn within a rectangular piece of paper. The left-over part of the paper is shaded. The side of square X measures 4 cm.

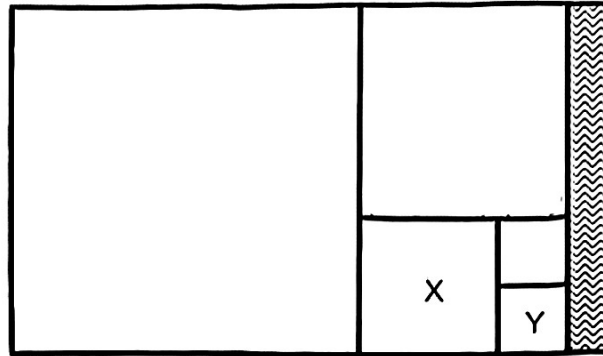

- (a) What is the length of the side of square Y?

Ans : (a) _____ [1]

- (b) The breadth of the left-over paper is 1.5 cm. What is the length of the rectangular piece of paper?

Ans : (b) _____ [2]

- (c) Paul cut out each of the five squares on the rectangular paper into 2-cm squares. He then used the 2-cm squares to form cubes. What is the greatest number of cubes Paul can make?

Ans : (c) _____ [4]

Please do not write in the margin.

Please do not write in the margin.

Please do not write in the margin.

Sub-Total :

13 In the figure, ABCD is a rhombus and ADEF is a trapezium. AF is parallel to DE.

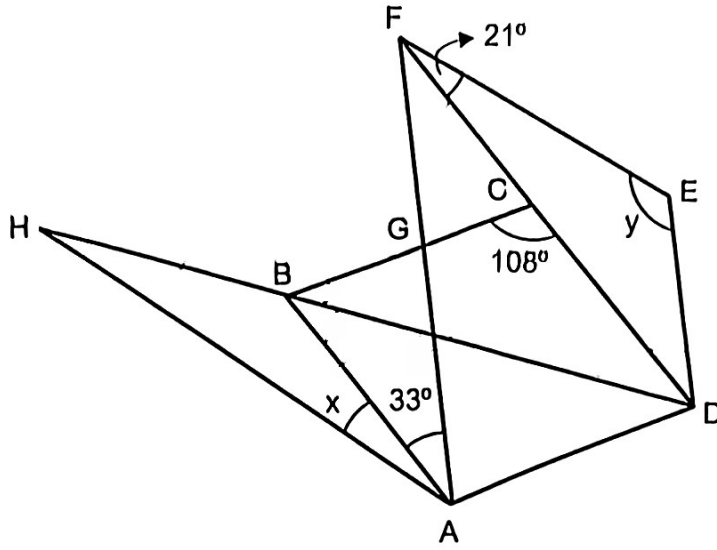

(a) Find $\angle x$.

Ans : (a) _____ [3]

(b) Find $\angle y$.

Ans : (b) _____ [2]

Please do not write in the margin.

Please do not write in the margin.

Please do not write in the margin.

Sub-Total :

- 14 There were almond and chocolate cookies in a container. Mrs Tan took out 35 almond cookies and 60% of the chocolate cookies. After that, the ratio of the number of almond cookies to the number of chocolate cookies in the container was 2 : 5.
- (a) What fraction of chocolate cookies did Mrs Tan take out from the container? Give your answer in the simplest form.

Ans : (a) _____ [1]

- (b) Mrs Tan had 154 more chocolate cookies than almond cookies at first. How many almond and chocolate cookies were left in the container in the end?

Ans : (b) _____ [3]

Please do not write in the margin.

Please do not write in the margin.

Please do not write in the margin.

Sub-Total :

- 15 Figure OABCD is formed by overlapping 2 similar quarter circles OAC and OBD. $OA = OB = OC = OD = 10$ cm. The area of the shaded part OBC is 30 cm^2 and the perimeter of the shaded part OBC is 26 cm.

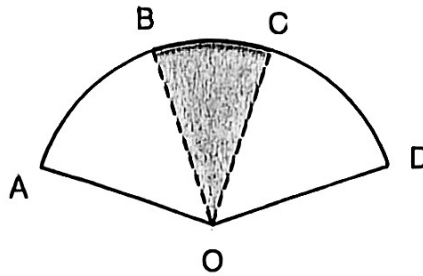

- (a) Find the area of figure OABCD. Take $\pi = 3.14$

Please do not write in the margin.

Ans : (a) _____ [2]

Please do not write in the margin.

- (b) Find the perimeter of figure OABCD. Take $\pi = 3.14$

Ans : (b) _____ [3]

Please do not write in the margin.

Sub-Total :

- 16 At a bookshop, erasers are sold only in packs of 8 and pencils are sold only in packs of 5.

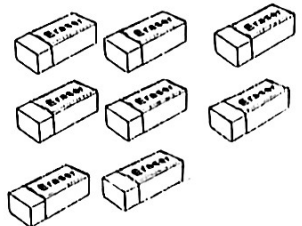
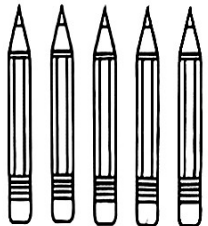
	
<p style="text-align: center;">Erasers 8 for \$2</p>	<p style="text-align: center;">Pencils 5 for \$3</p>

Mr Tan bought erasers and pencils for his company. He spent $\frac{1}{3}$ of his money on erasers and the rest of his money on pencils. He bought 36 more erasers than pencils. How much did Mr Tan spend altogether?

Please do not write in the margin.

Please do not write in the margin.

Ans : _____ [4]

Please do not write in the margin.

Sub-Total :

- 17 Ann filled some orange juice into large and small bottles. She filled $\frac{3}{5}$ of the orange juice into 4 large bottles and $\frac{3}{4}$ of the remaining orange juice into 9 small bottles.
- (a) What fraction of the orange juice was filled into the 9 small bottles?

Ans : (a) _____ [1]

- (b) After that, she wanted to fill 1 large bottle with the left-over orange juice but was short of 0.6 l. Instead, she filled another 1 small bottle and had 0.8 l of orange juice left in the end. How many litres of orange juice did Ann have at first?

Ans : (b) _____ [4]

End of Paper

Please do not write in the margin.

Sub-Total :

Please do not write in the margin.

Please do not write in the margin.

SCHOOL : ANGLO CHINESE SCHOOL (JUNIOR)

LEVEL : PRIMARY 6

SUBJECT : MATH











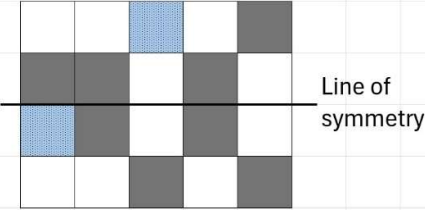





TERM : 2025 PRELIM EXAM

BOOKLET A

Q1	Q2	Q3	Q4	Q5	Q6	Q7	Q8	Q9	Q10
2	1	2	3	3	4	3	2	2	4
Q11	Q12	Q13	Q14	Q15					
4	1	2	3	4					

BOOKLET B

Q16	$4.5 \div 300 = 0.015$	ANS : 0.015
Q17	$\frac{3}{8} \times 12 = \frac{9}{2}$ or $4\frac{1}{2}$	ANS : $\frac{9}{2}$ or $4\frac{1}{2}$
Q18	$2 \text{ cm} \div 5 = 0.4 \text{ cm}.$ $(8 + 2 \times 0.4) - 2 = 8.8 - 2 = 6.8 \text{ cm}$	ANS : 6.8 cm
Q19	$210 - 25 = 185 \text{ min}$	ANS : 185 min
Q20	Length of the square base = $\sqrt{25} = 5 \text{ cm}$ Height of the cuboid = $60 \div 5 = 12 \text{ cm}$	ANS : 12 cm
Q21	$6 \div 7 = 0.857... = 0.86$ (2 decimal places)	ANS : 0.86
Q22	The 4-digit number = $210 \times 6 = 1260$ The correct answer = $1260 \div 7 = 188$	ANS : 180
Q23	(a) Total number of visitors to Bird Paradise in the week = $5 \times 3p + (6p + 70) + (9p - 25) = 15P + 15P + 45 = 30P + 45$ (b) $30P + 45 = 7395$, $30P = 7395 - 45 = 7350$, $P = 7350 \div 30 = 245.$	ANS : (a) $30P + 45$ (b) 245

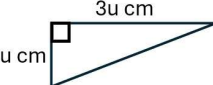
Q24	<p>(a) Percentage of students who liked bowling $= (100\% - 28\% - 32\%) \div 2 = 40\% \div 2 = 20\%$.</p> <p>(b) $32\% - 28\% = 4\% \rightarrow 10$, $100\% \rightarrow 10 \div 4 \times 100 = 250$.</p> <p style="text-align: right;">ANS : (a) 20% (b) 250</p>																
Q25	 <p style="text-align: right;">ANS : See figure</p>																
Q26	<p>(a) East</p> <p>(b)</p> <table border="1" data-bbox="406 735 698 1060"> <tbody> <tr> <td> Swing</td> <td></td> <td></td> <td> Rocking horse</td> </tr> <tr> <td></td> <td> Slide</td> <td></td> <td></td> </tr> <tr> <td></td> <td>X</td> <td></td> <td> See-saw</td> </tr> <tr> <td></td> <td></td> <td> Round-about</td> <td></td> </tr> </tbody> </table> <p style="text-align: right;">(b) See figure</p>	 Swing			 Rocking horse		 Slide				X		 See-saw			 Round-about	
 Swing			 Rocking horse														
	 Slide																
	X		 See-saw														
		 Round-about															
Q27	<p>(a) The difference = $290 - 140 = 150$ mm.</p> <p>(b) $\frac{160-140}{160} \times 100\% = \frac{20}{160} \times 100\% = \frac{100}{8}\% = 12.5\%$</p> <p style="text-align: right;">ANS : (a) 150 mm (b) 12.5%</p>																
Q28	<p>The discounted (sales) price = $\\$720 \div 90\% = \\800.</p> <p>The marked (original) price = $\\$800 \div 80\% = \\1000.</p> <p>Total amount of the discount = $\\$1000 - \\$720 = \\$280$.</p> <p style="text-align: right;">ANS : \$280</p>																
Q29	<p>$180^\circ - \angle x = 180^\circ - 124^\circ = 56^\circ$.</p> <p>$\angle y = 180^\circ - 2 \times 56^\circ = 180^\circ - 112^\circ = 68^\circ$.</p> <p style="text-align: right;">ANS : (a) 68°</p>																
Q30	 <p>Assume the shorter length of the two perpendicular sides of the triangle is u cm, then the longer side has a length of $3u$ cm.</p> <p>The perimeter of the rectangle = $2 \times (6u + 4u)$ cm = 80 cm $\rightarrow 20u = 80$, $u = 80 \div 20 = 4$.</p> <p>Area of one triangle = $0.5 \times 4 \times 12 = 24$ cm². ANS : 24 cm²</p>																

PAPER 2

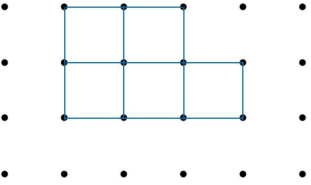
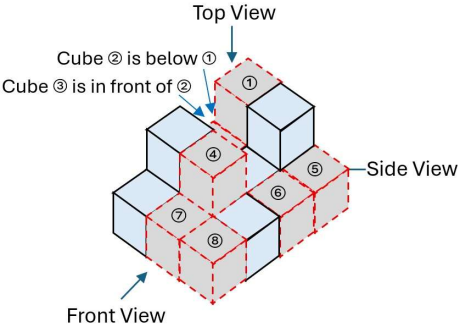
<p>Q1</p>	<p>Samad saved \$2.50 every day. To save \$15, he needs to save $\\$15 \div \\$2.50 = 6$ days. For every 6 days, he receives an additional of \$3 from his father → He saves $\\$15 + \\$3 = \\$18$ for every period of 6 days. $50 \div 6 = 8 \text{ R } 2$. Thus for 50 days, he saves a total amount of $= 8 \times \\$18 + 2 \times \\$2.50 = \\$144 + \\$5 = \\$149$. ANS : \$149</p>
<p>Q2</p>	<p>20% → \$240, 100% → $\\$240 \times 5 = \\1200 (amount Eric gives to his parents before the increase in income.) \therefore His income before the increase = $\\$1200 \times 4 = \\4800 ANS : \$4800</p>
<p>Q3</p>	<p>$\angle VRQ = 360^\circ - 256^\circ - 90^\circ = 14^\circ$, $\therefore \angle QRT = 180^\circ - 122^\circ - 14^\circ = 44^\circ$. ANS : 44°</p>
<p>Q4</p>	<p>Total of the four 2-digit numbers = $92 \times 4 = 368$. The three largest 2-digit numbers are 99, 98 and 97. \therefore The smallest possible number = $368 - (99 + 98 + 97) = 74$ ANS : 74</p>
<p>Q5</p>	<div style="display: flex; justify-content: space-between;"> <div style="width: 45%;"> <p>(a)</p>  <p>(b)</p>  </div> <div style="width: 45%;"> <p>From the diagram, the maximum number of cubes that can be added to the solid without changing the front view and side view is 8.</p> <p>ANS : (a) See figure (b) 8 cubes</p> </div> </div>

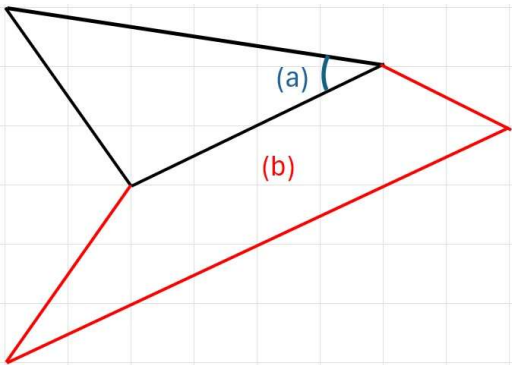
Q6	<p>(a) Percentage of Isabelle's money spent on food $= 24\% \div \frac{2}{5} = 24\% \times \frac{5}{2} = 12\% \times 5 = 60\%$.</p> <p>(b) Percentage of Isabelle's money saved $= 25\% \times 24\% = \frac{25}{100} \times 24\% = 4 \times 24\% = 6\%$.</p> <p>6% → \$90, $100\% - 6\% = 94\% \rightarrow \\$90 \div 6 \times 94 = \\$15 \times 94 = \\1410</p> <p style="text-align: right;">ANS : (a) 60% (b) \$1410</p>
Q7	<p>Tap A can fill the empty tank in 8 minutes. The tank was $\frac{2}{3}$ full of water. To fill the tank completely, time taken $= 8 \times \frac{1}{3} = \frac{8}{3} = 2\frac{2}{3}$ min = 2 minutes 40 seconds.</p> <p style="text-align: right;">ANS : $2\frac{2}{3}$ min or 2 minutes 40 seconds</p>
Q8	<p>(a) Frank's mass = y kg, Gideon's mass = $3y$ kg, Henry's mass = $(3y - 4)$ kg. Total mass of the three boys = $y + 3y + 3y - 4 = (7y - 4)$ kg.</p> <p>(b) Frank's mass = y kg = 28 kg, The difference between Frank's mass and Henry's mass $= (3y - 4) - y = 2y - 4 = 2(28) - 4 = 52$ kg.</p> <p style="text-align: right;">ANS : (a) $(7y - 4)$ kg (b) 52 kg</p>
Q9	<p>(a) $\angle ACB = 36^\circ$.</p> <p>(b)</p> <div style="text-align: center;">  </div> <p style="text-align: right;">ANS : (a) 36° (b) See figure</p>

Q10	<p>(a) Day 4 sold the most number of T-shirts.</p> <p>(b) $\frac{120-20}{120} \times 100\% = \frac{100}{120} \times 100\% = 83\%$ (nearest percent).</p> <p>(c) Number of T-shirts sold on Day 3 = $76 - 60 = 16$. Discounted price of a T-shirt = $\\$192 \div 16 = \\12. The price of a T-shirts before the discount = $\\$ \frac{12}{80\%} = \\$ 15$.</p> <p style="text-align: right;">ANS : (a) Day 4 (b) 83% (c) \$15</p>
Q11	<p>(a) $350 \div 25 = 14$ min.</p> <p>(b) $195 \times 14 = 2730$ m, $2730 \text{ m} \div 400 \text{ m} = 6.825$. Ray completed 6 rounds.</p> <p style="text-align: right;">ANS : (a) 14 min (b) 6 rounds</p>
Q12	<p>(a) Length of the side of square Y = $4 \div 2 = 2$ cm.</p> <p>(b) $2 + 4 = 6$, $6 + 4 = 10$. Length of the rectangular piece of paper = $10 + 4 + 2 + 1.5 = 17.5$ cm.</p> <p>(c) $2 \times 2 = 4$; $4 \times 4 = 16$, $16 \div 4 = 4$; $6 \times 6 = 36$, $36 \div 4 = 9$; $10 \times 10 = 100$, $100 \div 4 = 25$; Number of 2-cm squares = $25 + 9 + 4 + 2 = 40$, $40 \div 6 = 6 \text{ R } 4$ Greatest number of cubes Paul can make = 6.</p> <p style="text-align: right;">ANS : (a) 2 cm (b) 17.5 cm (c) 6 cubes</p>
Q13	<p>(a) $\angle ABD = \angle CBD = \angle CDB = (180^\circ - 108^\circ) \div 2 = 36^\circ$, $\angle x = \angle BHA = 36^\circ \div 2 = 18^\circ$.</p> <p>(b) $\angle AFD = \angle FAB = 33^\circ$, $\angle AFE = \angle AFD + \angle DFE = 33^\circ + 21^\circ = 54^\circ$, $\angle y = \angle DEF = 180^\circ - 54^\circ = 126^\circ$</p> <p style="text-align: right;">ANS : (a) 18° (b) 126°</p>

Q14	<p>(a) $60\% = \frac{60}{100} = \frac{3}{5} \therefore$ Mrs. Tan took out $\frac{3}{5}$ of chocolate cookies from the container.</p> <p>(b)</p> <table border="0" style="margin-left: 40px;"> <thead> <tr> <th></th> <th style="text-align: center;"><u>Almond</u></th> <th style="text-align: center;"><u>Chocolate</u></th> </tr> </thead> <tbody> <tr> <td>At the end</td> <td style="text-align: center;">4u</td> <td style="text-align: center;">10u</td> </tr> <tr> <td>Took out</td> <td style="text-align: center;">35</td> <td style="text-align: center;">15u</td> </tr> <tr> <td>At first</td> <td style="text-align: center;">(4u + 35)</td> <td style="text-align: center;">25u</td> </tr> </tbody> </table> <p>$25u - (4u + 35) = 154$, $21u = 154 + 35 = 189$, $u = 189 \div 21 = 9$. Number of almond and chocolate cookies were left in the end $= 14u = 14 \times 9 = 126$.</p> <p style="text-align: right;">ANS : (a) $\frac{3}{5}$ (b) 126</p>		<u>Almond</u>	<u>Chocolate</u>	At the end	4u	10u	Took out	35	15u	At first	(4u + 35)	25u								
	<u>Almond</u>	<u>Chocolate</u>																			
At the end	4u	10u																			
Took out	35	15u																			
At first	(4u + 35)	25u																			
Q15	<p>(a) Area of figure OABCD $= 2 \times \left(\frac{1}{4} \times 3.14 \times 10^2\right) - 30 = 127 \text{ cm}^2$.</p> <p>(b) Arc length BC = $26 - 20 = 6 \text{ cm}$, Arc length AD = $3.14 \times 10 - 6 = 25.4 \text{ cm}$, Perimeter of the figure OABCD = $25.4 + 10 + 10 = 45.4 \text{ cm}$.</p> <p style="text-align: right;">ANS : (a) 127 cm^2 (b) 45.4 cm</p>																				
Q16	<p>Mr. Tan spent $\frac{1}{3}$ of his money on erasers and the rest on pencils.</p> <table border="0" style="margin-left: 40px;"> <thead> <tr> <th></th> <th style="text-align: center;"><u>Erasers</u></th> <th style="text-align: center;">:</th> <th style="text-align: center;"><u>Pencils</u></th> </tr> </thead> <tbody> <tr> <td></td> <td style="text-align: center;">1</td> <td style="text-align: center;">:</td> <td style="text-align: center;">2</td> </tr> <tr> <td></td> <td style="text-align: center;">\$2</td> <td style="text-align: center;">:</td> <td style="text-align: center;">\$4</td> </tr> <tr> <td>$\rightarrow$</td> <td style="text-align: center;">\$6</td> <td style="text-align: center;">:</td> <td style="text-align: center;">\$12</td> </tr> <tr> <td>$\rightarrow$</td> <td style="text-align: center;">$3 \times 8 = 24$</td> <td style="text-align: center;">:</td> <td style="text-align: center;">$4 \times 5 = 20$</td> </tr> </tbody> </table> <p>$24 - 20 = 4$, $36 \div 4 = 9$. Total amount spent by Mr. Tan = $9 \times (\\$6 + \\$12) = \\$162$.</p> <p style="text-align: right;">ANS : \$162</p>		<u>Erasers</u>	:	<u>Pencils</u>		1	:	2		\$2	:	\$4	\rightarrow	\$6	:	\$12	\rightarrow	$3 \times 8 = 24$:	$4 \times 5 = 20$
	<u>Erasers</u>	:	<u>Pencils</u>																		
	1	:	2																		
	\$2	:	\$4																		
\rightarrow	\$6	:	\$12																		
\rightarrow	$3 \times 8 = 24$:	$4 \times 5 = 20$																		

Q17

$$(a) 1 - \frac{3}{5} = \frac{2}{5}, \quad \frac{3}{4} \times \frac{2}{5} = \frac{3}{10}.$$

(b) The capacity of a large bottle is $0.6 + 0.8 = 1.4 \text{ l}$ more than that of a small bottle.

$$\frac{3}{5} \text{ of the orange juice} \rightarrow 4 \text{ large bottles} \\ = 4 \text{ small bottles} + 5.6 \text{ l} \text{ ----- } \textcircled{1}$$

$$\frac{3}{10} \text{ of the orange juice} \rightarrow 9 \text{ small bottles, or}$$

$$\frac{3}{5} \text{ of the orange juice} \rightarrow 2 \times 9 = 18 \text{ small bottles} \text{ ----- } \textcircled{2}$$

$$\text{From } \textcircled{1} \text{ and } \textcircled{2}, 18 \text{ small bottles} = 4 \text{ small bottles} + 5.6 \text{ l}, \\ 14 \text{ small bottles} = 5.6 \text{ l},$$

$$\therefore 1 \text{ small bottle} = 5.6 \text{ l} \div 14 = 0.4 \text{ l}.$$

$$\text{From } \textcircled{2}, \frac{3}{5} \text{ of the orange juice} \rightarrow 18 \times 0.4 \text{ l} = 7.2 \text{ l},$$

$$\therefore \text{Amount of orange juice Ann had at first} = 7.2 \div \frac{3}{5} = 12 \text{ l}.$$

$$\text{ANS : (a) } \frac{3}{10}$$

$$(b) 12 \text{ l}$$

