

Anglo-Chinese School (Junior)



PRELIMINARY EXAMINATION (2025)

PRIMARY 6
SCIENCE
(BOOKLET A)

20 August 2025

Total Time for Booklets A and Booklet B : 1 hour 45 minutes

Name: _____ Class: 6 _____

INSTRUCTIONS TO CANDIDATES

1. Write your Index No. in the boxes at the top right hand corner.
2. Do not turn over this page until you are told to do so.
3. Follow all instructions carefully.
4. Answer all questions.
5. Use a 2B pencil to shade your answers on the Optical Answer Sheet (OAS).

This booklet consists of 19 printed pages.

For each question from 1 to 28, four options are given. One of them is the correct answer. Make your choice (1, 2, 3 or 4) and shade your answer on the Optical Answer Sheet.

(56 marks)

1 The following are characteristics of organism X.

- A It has wings.
- B It has three body parts.
- C It has three pairs of legs.
- D It reproduces by laying eggs.

Which characteristics can be used to conclude that organism X is an insect?

- (1) A and B only
 - (2) A and D only
 - (3) B and C only
 - (4) A, B, C and D
- 2 Q, R, S and T represent the different stages in the life cycle of a butterfly. The butterfly is able to reproduce at stage R.

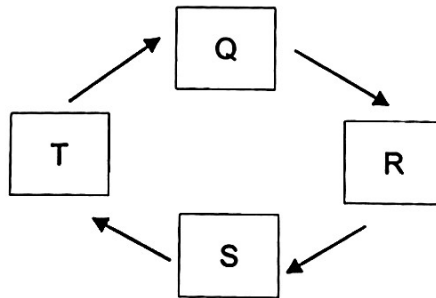

At which stage, Q, R, S and T, is the butterfly considered a pest to farmers?

- (1) Q
- (2) R
- (3) S
- (4) T

- 3 Scientists observed that Island P had no plants or animals. A few years later, they found new plants growing there. The diagram shows Island P and a nearby island Y.

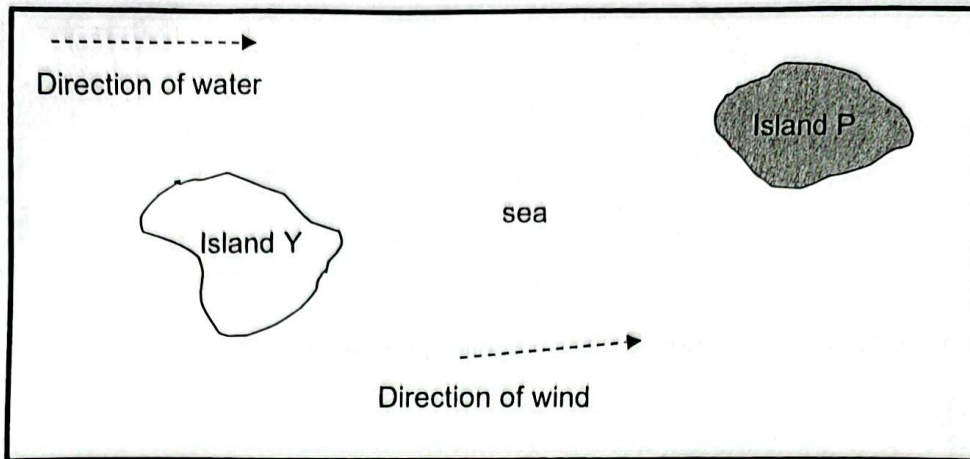

They also observed that some fruits that were found on Island Y were also present on Island P.

Which of the fruits A, B, C, and/or D are most likely to be found on both islands?

Fruit A	Fruit B	Fruit C	Fruit D
<p>waterproof layer</p>	<p>wings</p>	<p>light with tiny hairs</p>	<p>hard pod</p>

- (1) C only
- (2) D only
- (3) A, B and C only
- (4) A, B, C and D

- 4 Process X takes place in the human female reproductive system.

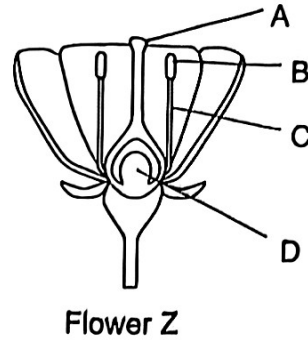
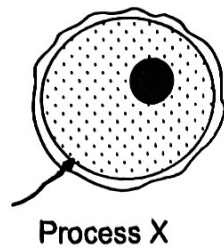

In which part of the flower Z does a similar process occur?

- (1) A
 (2) B
 (3) C
 (4) D
- 5 The table shows the main functions of organs W, X, Y and Z that are part of the human digestive system.

Function	Organ(s)
Digestion of food	W, X, Z
Absorption of digested food	W
Absorption of water	Y

What are organs W, X, Y and Z?

	W	X	Y	Z
(1)	Stomach	Mouth	Large intestine	Small intestine
(2)	Stomach	Large intestine	Small intestine	Mouth
(3)	Small intestine	Stomach	Large intestine	Mouth
(4)	Small intestine	Mouth	Stomach	Large intestine

- 6 Three of the leaves from the pot of plant were wrapped with three different types of plastic bags of the same size as shown in the table. The pot of plant was left under bright sunlight for some time.

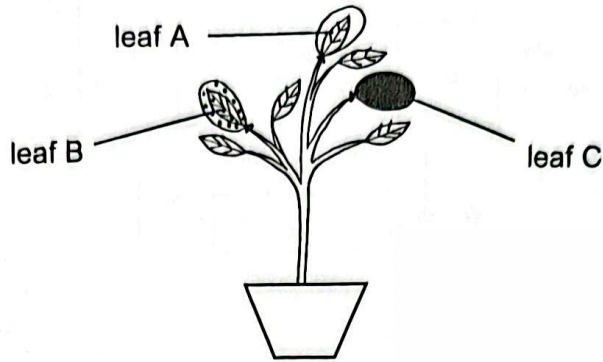

Leaf	A	B	C
Type of plastic bag	Clear plastic bag	Clear plastic bag with holes	Black plastic bag

Which of the following graphs correctly represents the amount of food made by leaves, A, B and C, after five hours?

(1)

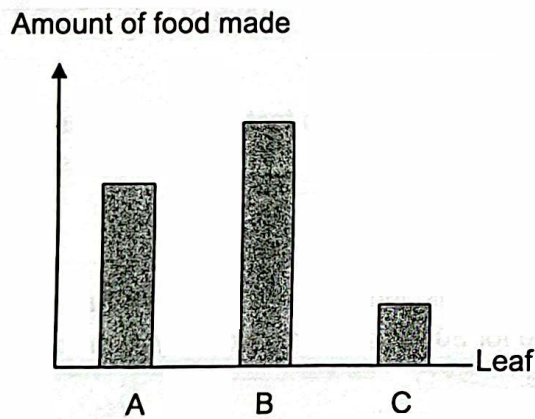

(2)

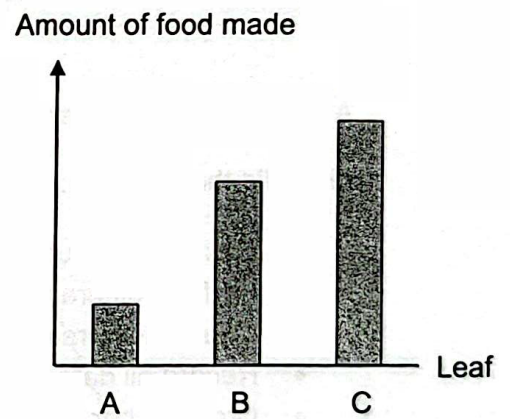

(3)

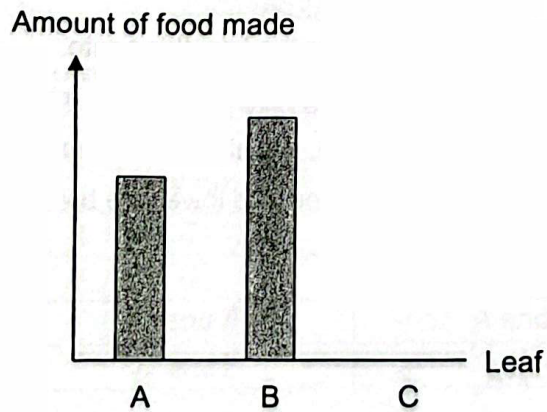

(4)

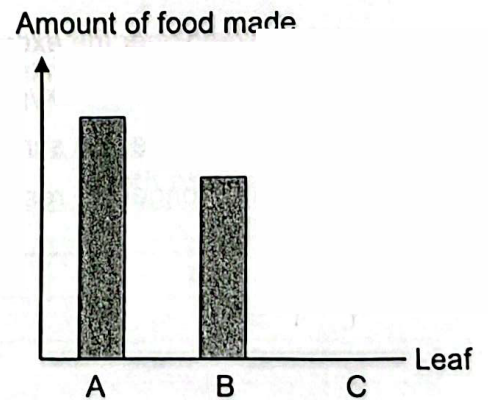

- 7 The diagram shows the different paths taken by food and water in a plant with parts A, B, C and D.

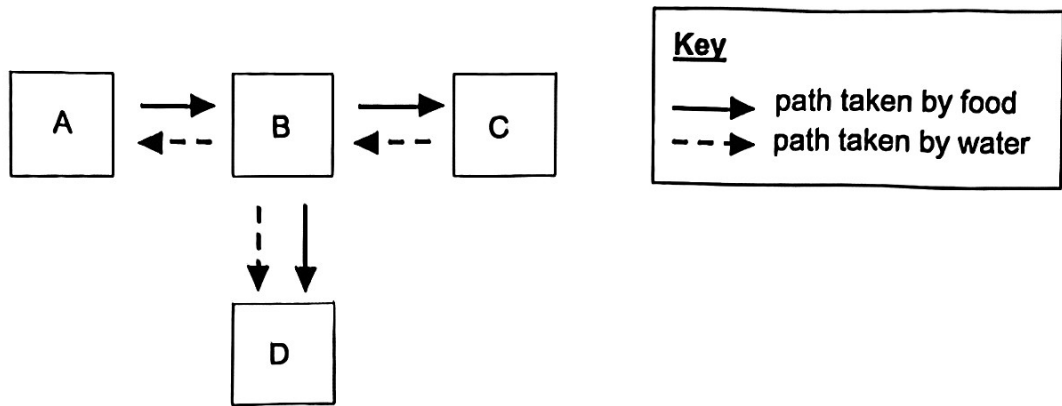

Which of the following represents A, B, C and D?

	A	B	C	D
(1)	leaf	stem	root	fruit
(2)	root	stem	fruit	leaf
(3)	flower	leaf	root	stem
(4)	stem	root	leaf	flower

- 8 A group of students carried out an investigation to test their hypothesis.

They did the following:

- Rest for 2 minutes and record initial breathing rate.
- Perform different exercises (walk, jump and run) for 1 minute each.
- Count their breathing rate for 30 seconds immediately after each exercise.
- Record all data in a table.
- Create a bar graph to compare results.

Which hypothesis is most suitable for this investigation?

- (1) The higher the exercise intensity, the higher the breathing rate.
- (2) The lower the oxygen level in the air, the higher the breathing rate.
- (3) The higher the surrounding air temperature, the higher the breathing rate.
- (4) The longer the rest period between exercises, the lower the breathing rate.

9 Study the flowchart.

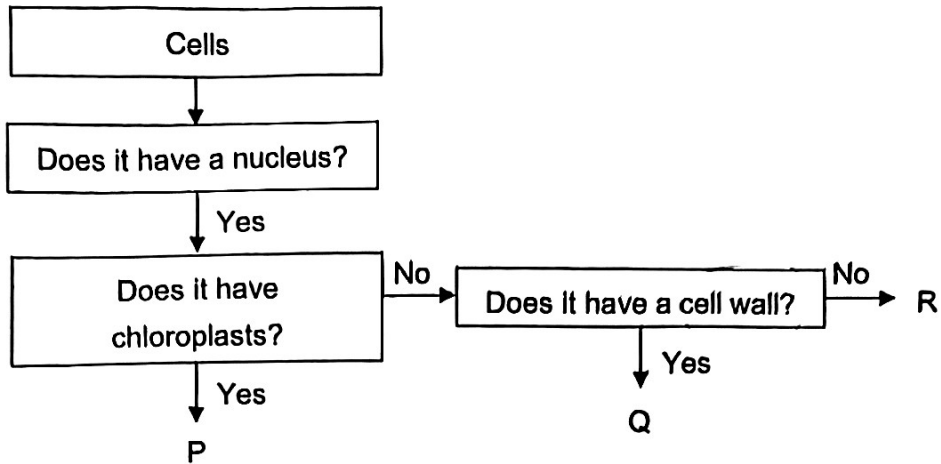

Where are cells, P, Q and R, taken from?

	P	Q	R
(1)	Leaf of plant	Root of plant	Skin of human
(2)	Leaf of plant	Flower of plant	Stem of plant
(3)	Stem of plant	Skin of human	Root of plant
(4)	Stem of plant	Flower of plant	Root of plant

10 Study the food web.

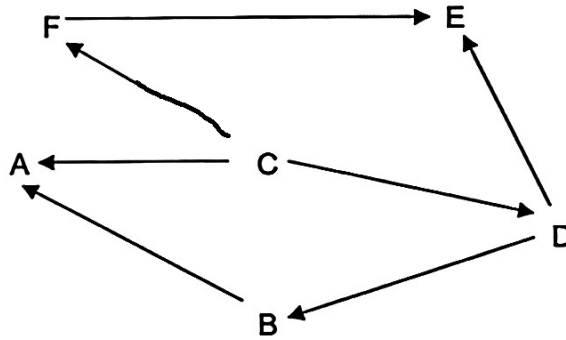

Which one of the following shows the correct relationship among the various organisms in the food web?

	Prey only	Predator only	Both prey and predator
(1)	C	E	A, B, D and F
(2)	C	A and E	B, D and F
(3)	D and F	A and E	B
(4)	D and F	A	B

- 11 The graph shows the change in the area covered by plant G in a garden. Animal X was introduced to the garden community at week 4.

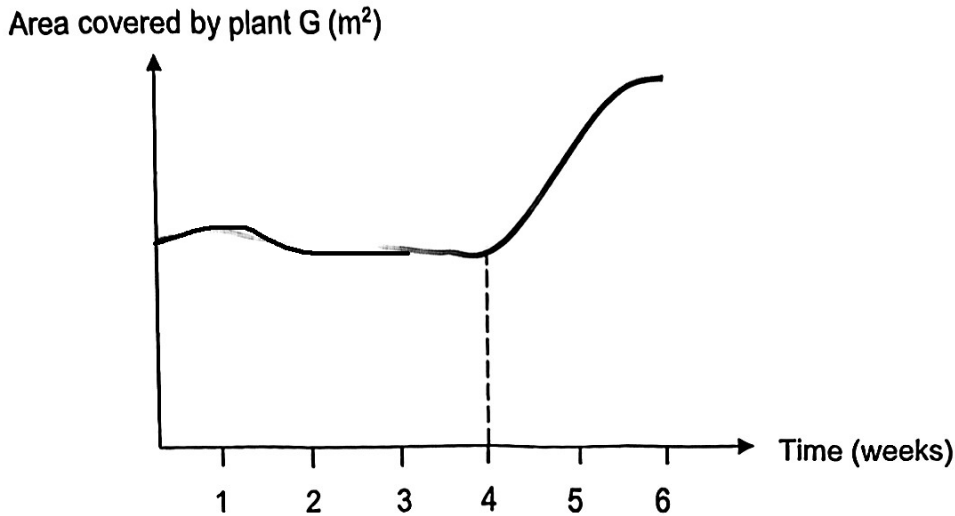

Which of the statements could explain the increase in the area covered by plant G after week 4?

- A Animal X helped plant G disperse its seeds.
- B Animal X preyed on animals that fed on plant G.
- C Animal X fed on plant G and plant G reproduced.
- D The waste from animal X helped plant G grow faster.

- (1) A and D only
- (2) B and C only
- (3) A, B and D only
- (4) B, C and D only

- 12 Three organisms, R, S and T, have characteristics that help them survive in their habitat as shown in the table.

Organism	Characteristic
R	Have needle-shaped leaves
S	Have air spaces in its leaf stalk
T	Trap air bubbles

Which of the following organisms' characteristics have been correctly matched to their function?

	To breathe in water	To reduce water loss	To float on water
(1)	T	S	R
(2)	T	R	S
(3)	S	R	T
(4)	S	T	R

- 13 The PSI (Pollutant Standards Index) gives an indication of air quality. The table shows what the air quality is like based on the PSI value.

PSI Value	Air Quality
1 - 50	Good
51 - 100	Moderate
101 - 200	Unhealthy
201 - 300	Very Unhealthy
Above 300	Hazardous

The PSI values of a town over five days are shown in the table.

Day	1	2	3	4	5
PSI value	46	48	123	147	144

Which one of the following is most likely to have caused the PSI value to increase from Day 2 to Day 4?

- (1) A few trees were cut down.
 - (2) More forest fires happened nearby.
 - (3) More farmers started growing vegetables.
 - (4) More people switched from fuel cars to electrical cars.
- 14 Plants use their leaves to make food through the process of photosynthesis.

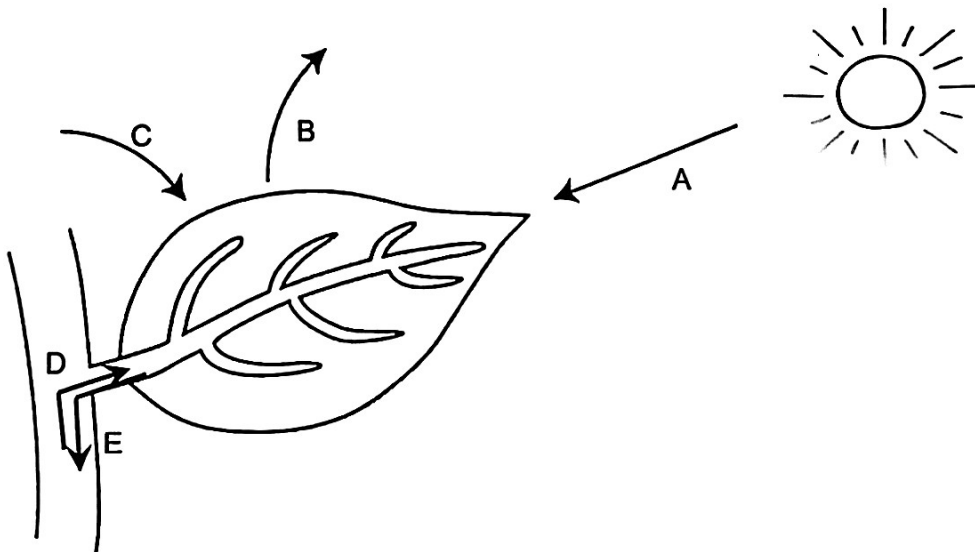

Which of the following best represents the letters A, B, C, D and E during photosynthesis?

	A	B	C	D	E
(1)	Heat	Carbon Dioxide	Oxygen	Glucose	Chlorophyll
(2)	Sunlight	Oxygen	Carbon Dioxide	Glucose	Chlorophyll
(3)	Heat	Carbon Dioxide	Oxygen	Water	Glucose
(4)	Sunlight	Oxygen	Carbon Dioxide	Water	Glucose

- 15 Mr Chan used two set-ups, A and B, to conduct an investigation. When he poured water into set-up A, only a small amount of water flowed into the flask as shown. However, when he poured the same amount of water into set-up B, all the water flowed in.

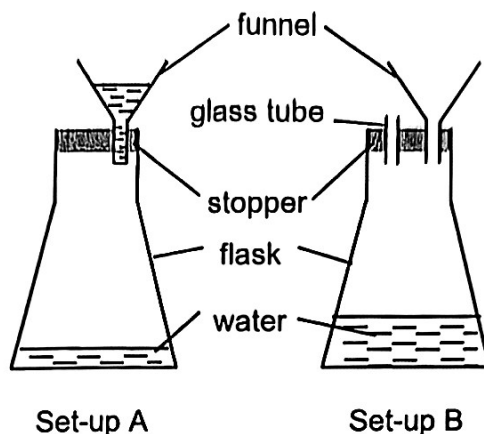

Which of the following best explains Mr Chan's observation?

- (1) Air in set-up B was compressed.
- (2) Water in set-up B was compressed.
- (3) The glass tube in set-up B allowed air to escape.
- (4) The water in set-up A occupied the space in the flask so more water could not flow in.

- 16 The diagram shows the water cycle.

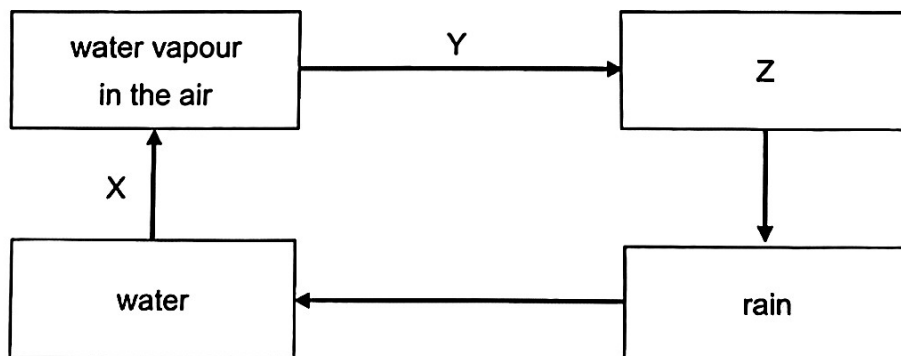

Which of the following correctly identifies X, Y and Z?

	X	Y	Z
(1)	condensation	evaporation	snow
(2)	condensation	condensation	cloud
(3)	evaporation	evaporation	snow
(4)	evaporation	condensation	cloud

- 17 Four identical containers, P, Q, R and S, were filled with the same amount of water. They were placed at four different locations under varying conditions for a day as shown.

Container	Condition	
	Sunny	Windy
P	No	Yes
Q	Yes	No
R	Yes	Yes
S	No	No

The conditions remained constant throughout the experiment.

Which of the following graphs shows the possible amount of water left in containers P, Q, R and S after one day?

(1) Amount of water (mℓ)



(2) Amount of water (mℓ)

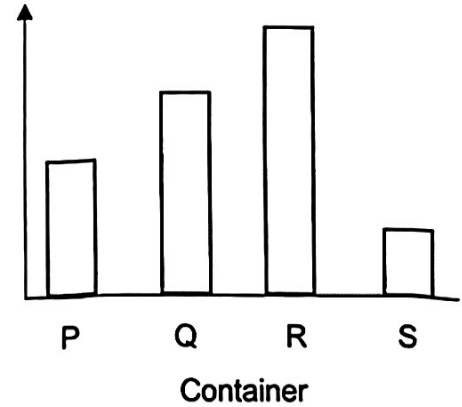

(3) Amount of water (mℓ)

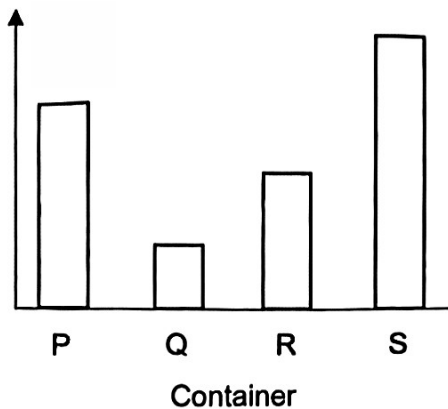

(4) Amount of water (mℓ)

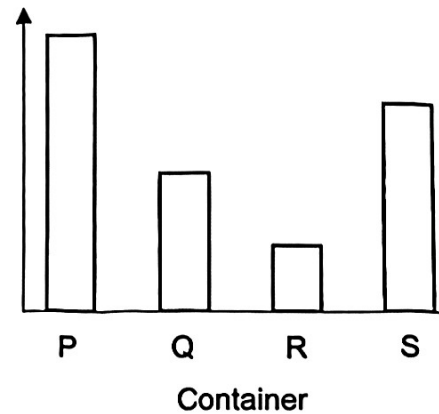

- 18 The diagram shows four circuits with identical batteries and bulbs.

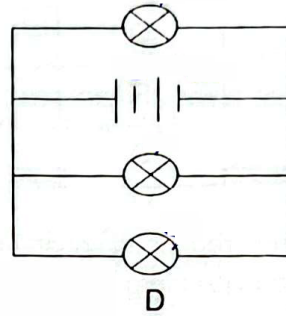
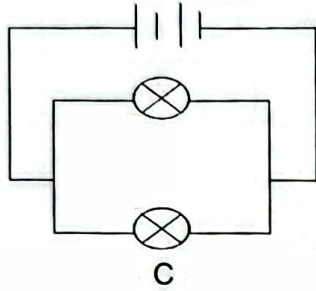
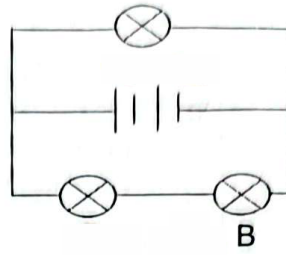
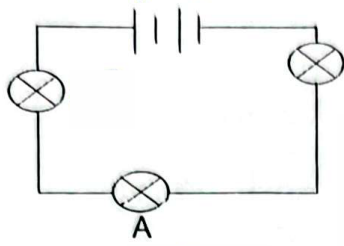

Which of the bulbs, A, B, C or D, will be the **least** bright?

- (1) A
- (2) B
- (3) C
- (4) D

19 The diagram shows a toy with an electric circuit.





The table shows the observations when the two switches in the circuit are open and/or closed.

Switch 1	Switch 2	Observation
Closed	Open	Light only
Open	Closed	Music only
Closed	Closed	Music and light
Open	Open	No music and light

Which of the following represents the circuit in the toy?

Key:

 Buzzer for music

 Light

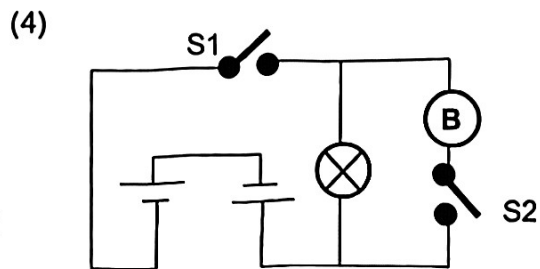
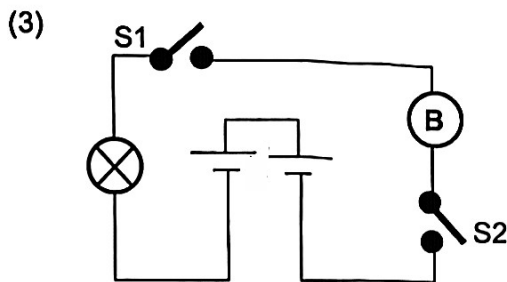
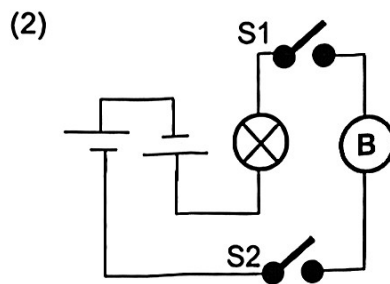
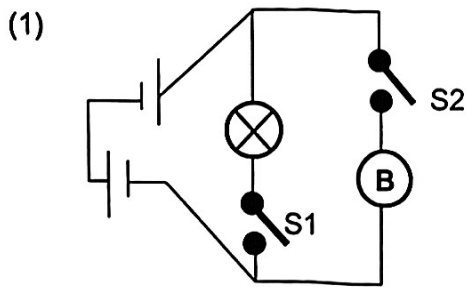

- 20 The diagram shows three magnets with ends, CD, EF and GH.

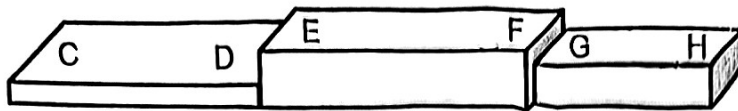

Which ends will repel?

- (1) C and F
 - (2) C and H
 - (3) D and G
 - (4) D and H
- 21 Ali strokes a nail 50 times with a magnet as shown.

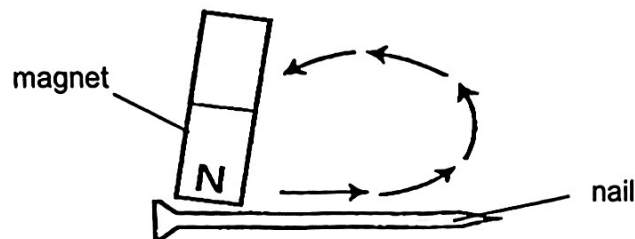

He brought the nail near a pile of iron pins and observed that it did **not** attract any of the iron pins.

Which of the following explains his observation?

- (1) He stroked the nail in the wrong direction.
- (2) The nail had become a temporary magnet.
- (3) The nail is made of non-magnetic material.
- (4) He used the North pole of the magnet to stroke the nail.

- 22 Marble R was rolling from point X on a carpeted floor. It was hit by marble S causing a change. Marble R continued moving and eventually stopped at point Y as shown.

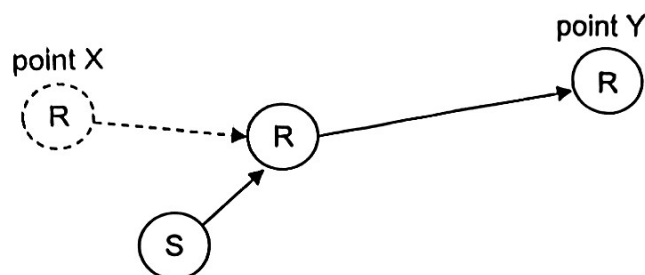

Based on the experiment, what can be concluded about the effects of forces acting on marble R?

- A A force can stop a moving object.
 - B A force can change the size of an object.
 - C A force can change the direction of a moving object.
- (1) A and B only
 (2) A and C only
 (3) B and C only
 (4) A, B and C

- 23 Belle hung two identical objects, A and B, on two identical springs. Object A was hung in the air while object B was hung in a container of sand as shown. She then lifted the two springs with the object upwards by 5cm.

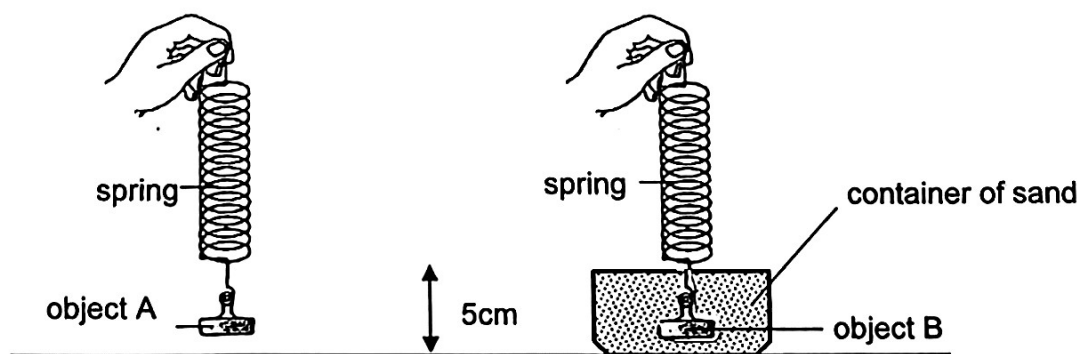

Which one of the following statements is **incorrect**?

- (1) More force is needed to lift object B.
- (2) Gravitational force is acting on objects A and B.
- (3) More gravitational force is acting on object A than on object B.
- (4) There is more force acting downwards on object B due to the sand.

- 24 Sea turtle hatchlings, the young of turtles, crawl to the sea after hatching. They are guided by light reflected off the water as they make their way to the sea. However, bright lights from nearby car parks can confuse them.

Legend

Δ Location of sea turtle eggs

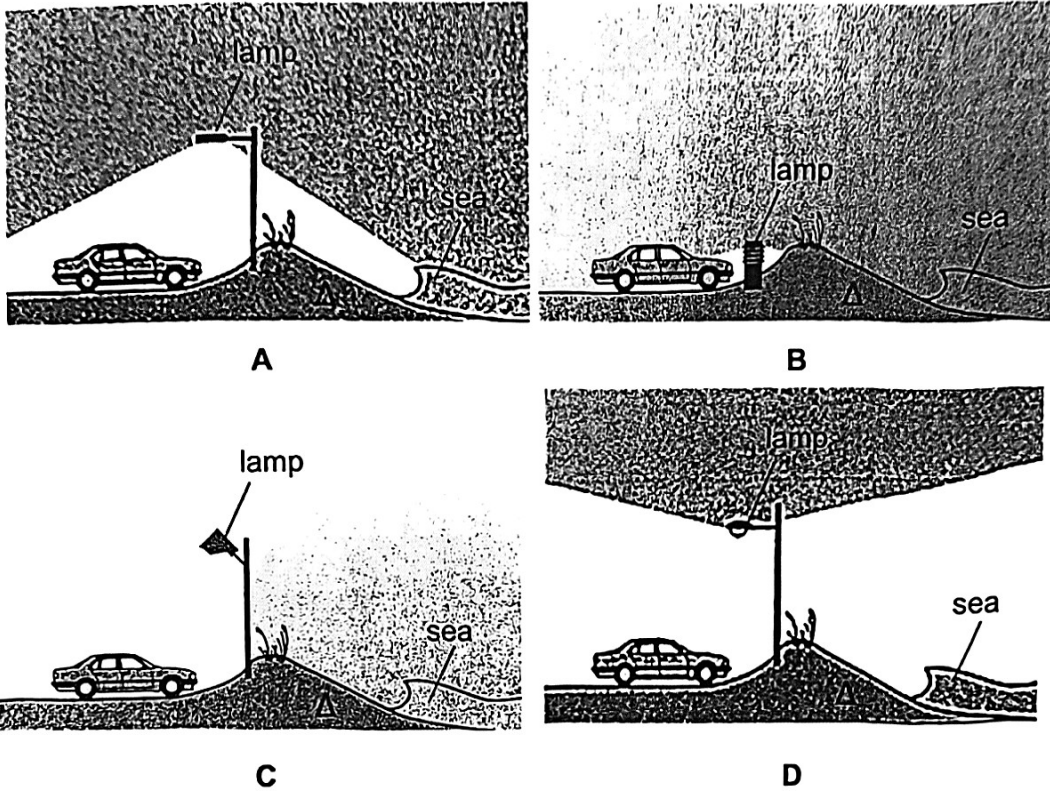

Which streetlamp, A, B, C or D, is **least** likely to confuse hatchlings?

- (1) A
 (2) B
 (3) C
 (4) D

- 25 Dave attached three identical pieces of wax, A, B and C, to a metal frame with equal sides as shown. When Dave heated the frame at a particular spot, the wax melted in the following order, B, A, C.

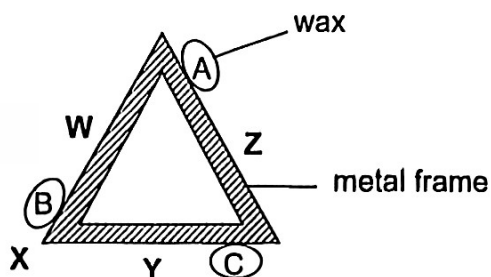

At which spot, W, X, Y or Z, did Dave heat the metal frame?

- (1) W
 - (2) X
 - (3) Y
 - (4) Z
- 26 Maverick set up an experiment as shown to compare how well four rods, A, B, C and D, made of different materials, conduct heat. The similar-sized rods at 30°C were placed in a container of crushed ice at the same time.

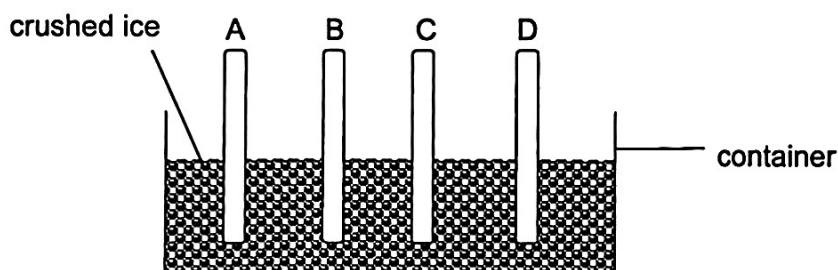

The table shows the temperature of each rod after five minutes.

Rod	Temperature (°C)
A	20
B	14
C	8
D	25

What can Maverick conclude about the heat conductivity of the materials of the rods, A, B, C and D?

- (1) D is the best conductor of heat.
- (2) C is the poorest conductor of heat.
- (3) B is a better conductor of heat than A.
- (4) C is a poorer conductor of heat than D.

- 27 The diagram shows a metal spoon in a bowl of ice cream.

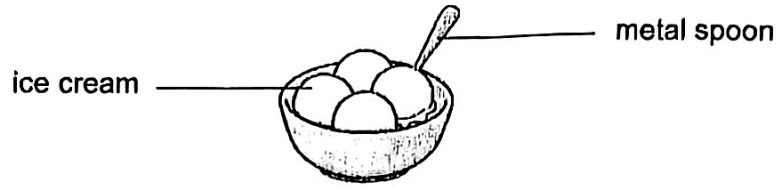

Which graph shows the changes in temperature of the metal spoon and the ice cream over time?

Key: — Ice cream
----- Metal spoon

(1)

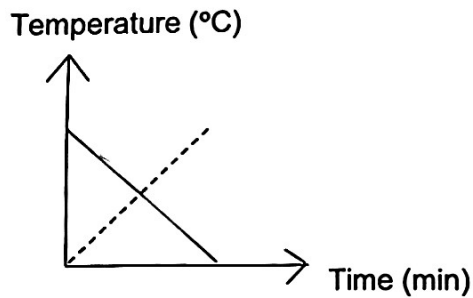

(2)

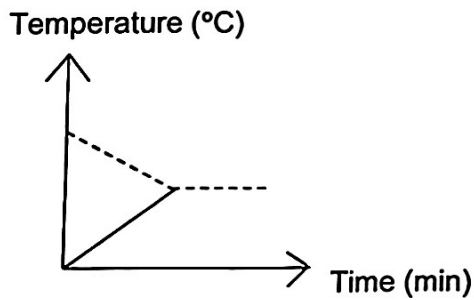

(3)

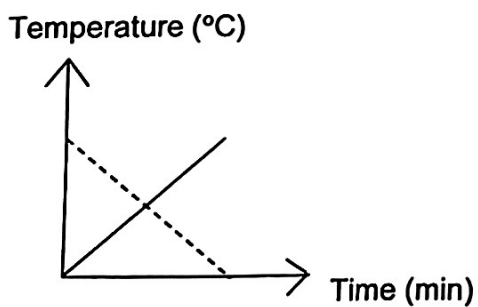

(4)

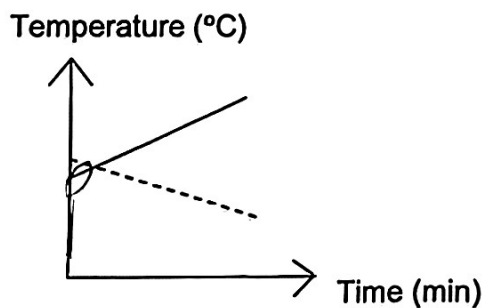

- 28 Jace carried out an experiment with a pendulum. He lifted the bob to position A and let it swing to position B, C and then back to X.

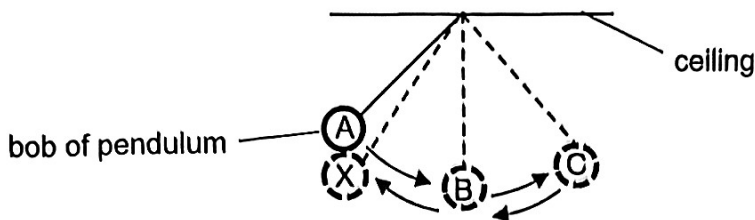

Which graph shows how the gravitational potential energy of the bob changes as it swings from position A to C and to X?

- (1) Gravitational potential energy
-
- (2) Gravitational potential energy
-
- (3) Gravitational potential energy
-
- (4) Gravitational potential energy
-

Anglo-Chinese School (Junior)



PRELIMINARY EXAMINATION (2025)

PRIMARY 6
SCIENCE
(BOOKLET B)

20 August 2025

Total Time for Booklets A and Booklet B : 1 hour 45 minutes

Name: _____ ()

Class: 6 _____

Parent's Signature: _____

INSTRUCTIONS TO CANDIDATES

1. Do not turn over this page until you are told to do so.
2. Follow all instructions carefully.
3. Answer all questions.
4. Use a dark blue or black ballpoint pen to write your answers and use a pencil for drawings, diagrams or graphs.
5. Do not use correction fluid/tape.
6. Do not use highlighter on any part of your answers.

Booklet	Possible Marks	Marks Obtained
A	56	
B	44	
Total	100	

For questions 29 to 40, write your answers in this booklet. The number of marks available is shown in brackets [] at the end of each question or part question. (44 marks)

- 29 Jinu measured the heart rate of five children while they were listening to slow-paced music, no music and fast-paced music.

He recorded his results in the table.

Child	Heart Rate (per minute)		
	Slow-paced Music	No Music	Fast-paced Music
A	78	85	110
B	73	83	98
C	68	74	88
D	72	79	90
E	70	80	92

- (a) State the aim of Jinu's experiment. [1]

- (b) State the relationship between the pace of music that children listen to and their heart rate. [1]

- (c) Suggest one improvement to Jinu's experiment to obtain more accurate results. [1]

(Go on to the next page)

SCORE	3
-------	---

30 The diagram shows a pond community.

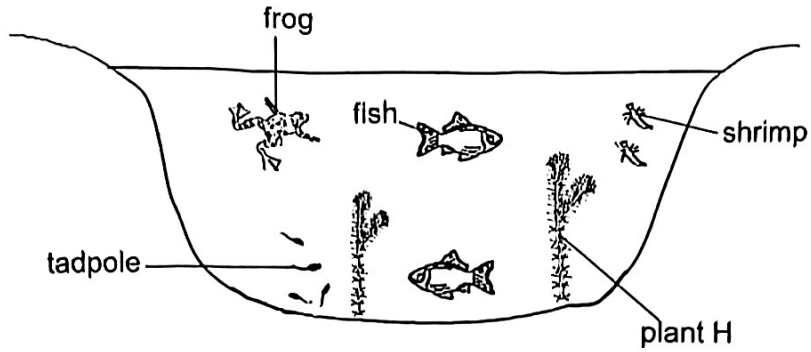

(a) How many populations are shown in the diagram? [1]

The graph shows the amount of oxygen in the pond from the time when muddy water from a nearby farm was washed into the pond.

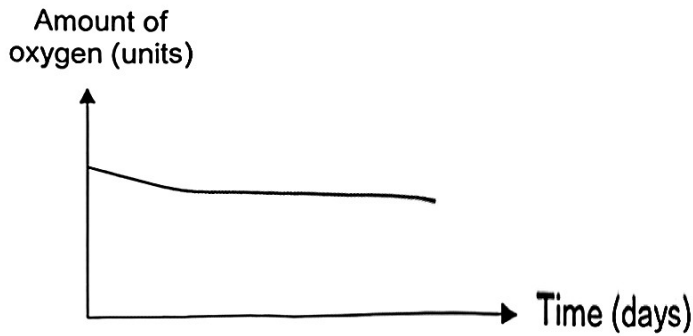

(b) The amount of oxygen in the pond decreased over time. Explain why. [1]

(c) Which organism shown in the diagram is most likely to survive? Explain why. [1]

Please do not write in the margin.

Please do not write in the margin.

(Go on to the next page)

SCORE	
	3

- 31 Monkey A has a short tail and thick fur that is light-brown in colour. Monkey B has a long tail and thick fur that is red in colour.

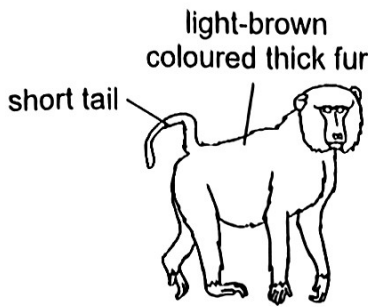

Monkey A

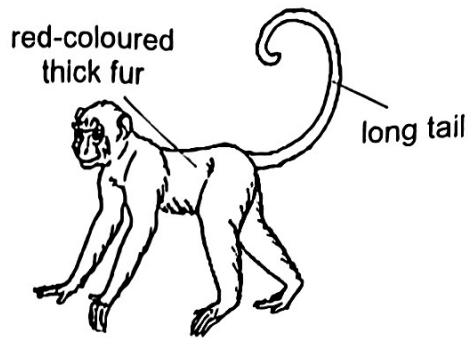

Monkey B

A dry open grassland has yellow coloured grass and very few trees while a rainforest has many tall trees.

- (a) Which monkey survives better in each habitat? Explain why.

[2]

Grassland:

Rainforest:

- (b) At night, the surrounding temperature of both the grassland and rainforest decreases by at least 5°C.

Explain why having thick fur is advantageous to both monkeys.

[1]

Please do not write in the margin.

Please do not write in the margin.

(Go on to the next page)

SCORE	3
-------	---

32 James observed flower C and recorded the following observations.

- It has no scent.
- Its petals are small and dull in colour.
- Its anthers and feathery stigma hang outside the petals.

(a) State how flower C is likely pollinated. [1]

James also observed two other flowers, D and E, as shown.

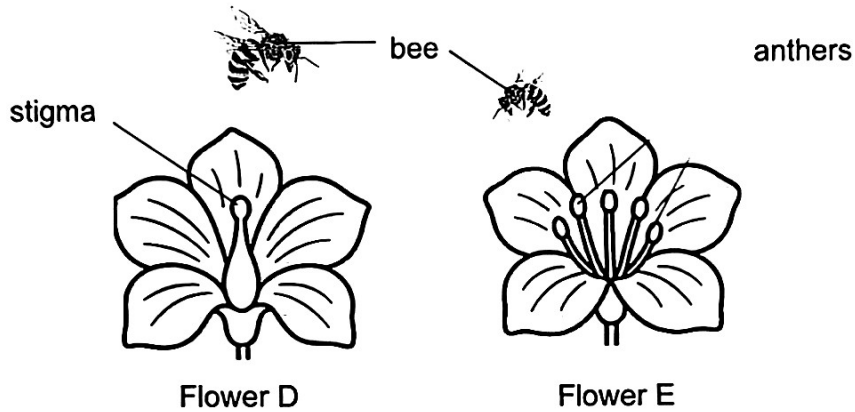

Please do not write in the margin.

Please do not write in the margin.

(bi) Which flower, D or E, is able to develop into a fruit? Explain why. [1]

(bii) James noticed bees visiting both flowers. State how the bees and the flowers benefit from each other. [2]

(Go on to the next page)

SCORE	4
-------	---

33 Mingzhe bought hot and iced coffee from a cafe. The coffee was served in paper cups with clear plastic lids. He noticed that there was a plastic coating inside the cups.

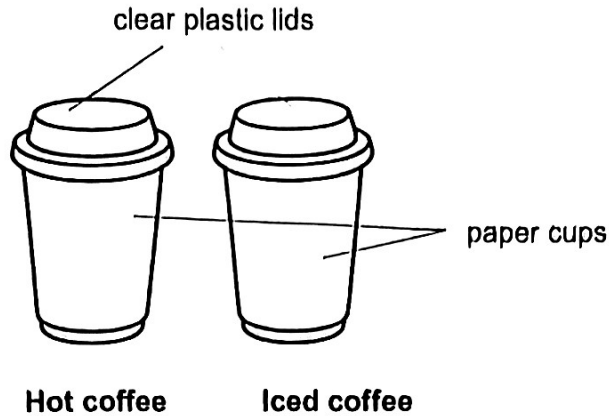

Please do not write in the margin.

Please do not write in the margin.

(a) Mingzhe's left hand felt warm when he was holding the cup of hot coffee and his right hand felt cold when holding the cup of iced coffee. Explain why. [1]

(b) Mingzhe could see through the clear plastic lids but not through the paper cup. Explain why. [1]

(c) Mingzhe observed that the paper cups containing coffee did not leak. He thinks the plastic coating inside the cups prevents leakage. Suggest a way he can test his idea. [1]

(Go on to the next page)

SCORE	3
-------	---

34 A security guard needs to control two 'slow down' signs at different entrance gates. Each entrance gate has its own bulb that lights up the sign. The guard must be able to switch on or off the bulb for each sign independently, depending on the traffic situation at each gate.

(a) The diagram shows part of the circuit. Complete the circuit so that it will work as described. [3]

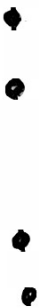
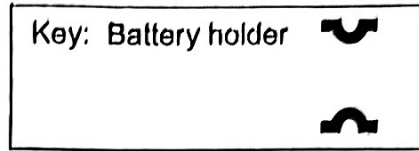

Please do not write in the margin.

Please do not write in the margin.

(b) State an advantage of the way you have connected the bulbs in part (a). [1]

(Go on to the next page)

SCORE	4
-------	---

- 35 Jarrell wanted to investigate which glass, A or B, keeps water cold for a longer time. Both glasses were made of the same material.

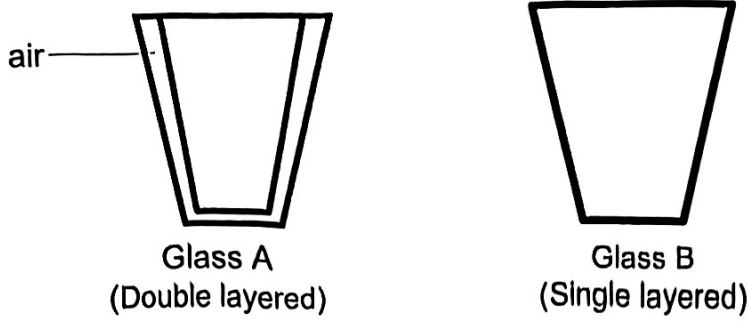

He measured the temperature of water in each glass at the start of the experiment and every 10 minutes for 50 minutes. He plotted the results in the graph.

Temperature of water ($^{\circ}\text{C}$)

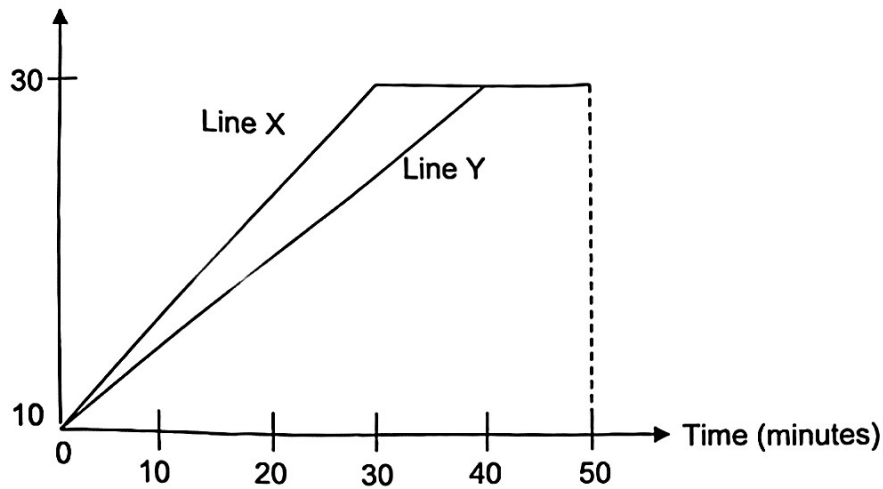

Please do not write in the margin.

Please do not write in the margin.

- (a) Complete the table by matching the lines X and Y to glasses, A and B. [1]

Line	Glass
X	
Y	

- (b) State two variables that Jarrell must keep constant to conduct a fair test. [1]

(Go on to the next page)

SCORE	2
-------	---

- (c) State the increase in the temperature of the water in glass A when it reached room temperature [1]

- (d) The table shows the daily average temperature for Singapore during the day.

	Average temperature ($^{\circ}\text{C}$) in the day
Inside the house	28 $^{\circ}\text{C}$
Outside the house	32 $^{\circ}\text{C}$

- Are double-layered or single-layered glass windows more suitable for houses in Singapore, so that it is cooler inside the house? Explain your answer. [2]

Please do not write in the margin.

Please do not write in the margin.

(Go on to the next page)

SCORE	3
-------	---

- 36 Elliott visits a new eco-friendly playground where children's movements and/or energy from solar panels are used to generate electricity and light up the playground. The wheel is connected to a generator which allows electricity to be produced to power the lights in the playground.

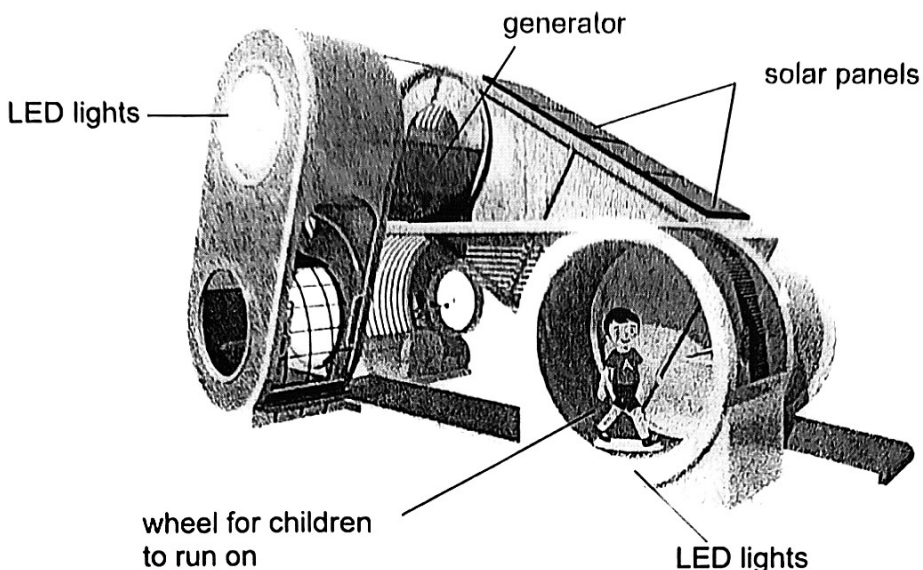

Please do not write in the margin.

Please do not write in the margin.

- (a) Where does Elliott's energy come from? [1]

- (b) Fill in the boxes to show the conversion of energy when a child is running on the wheel. [1]

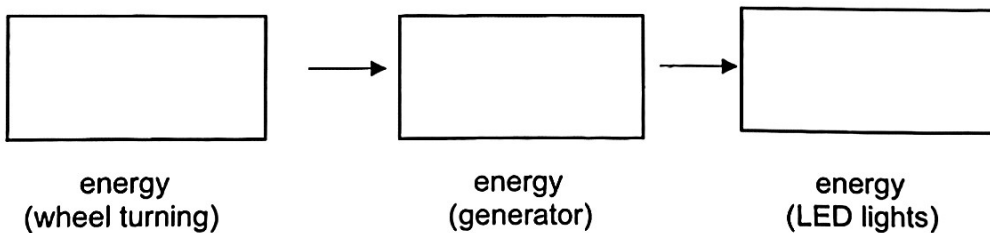

- (c) State one advantage of the solar panels. [1]

(Go on to the next page)

SCORE	3
-------	---

- 37 John set-up a circuit that is fixed to a box with a seesaw attached to the top where the ducks can move up and/or down. The seesaw has identical plastic ducks with iron rings of different masses attached as shown.

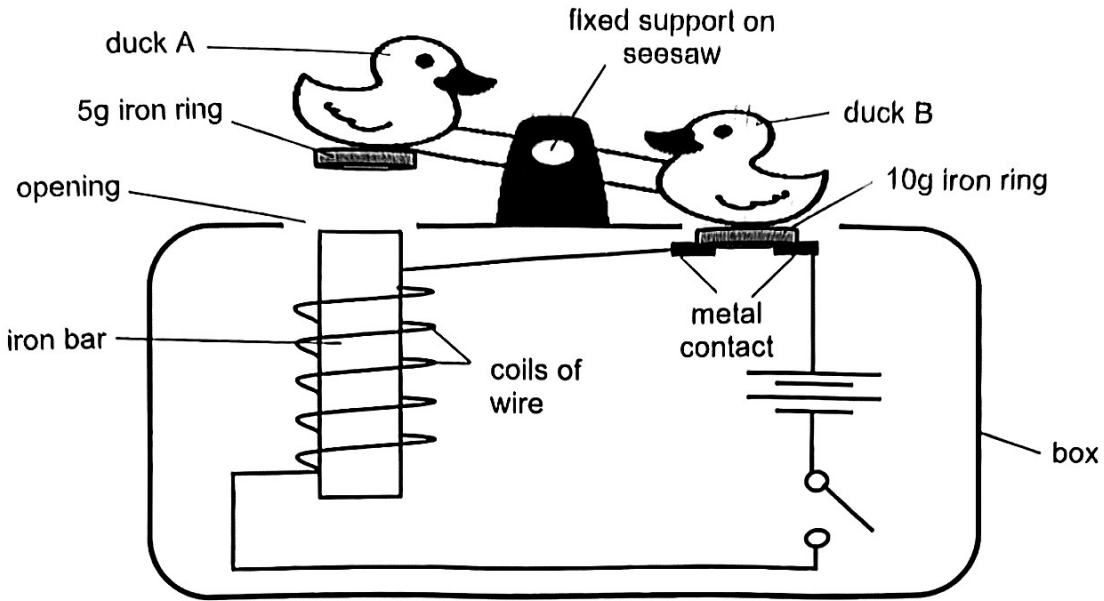

Please do not write in the margin.

Please do not write in the margin.

- (a) When John closed the switch, both ducks moved up and/or down continuously. [2]
Explain why.

- (b) What could John do to the circuit to make the ducks move up and/or down faster? [1]

(Go on to the next page)

SCORE	
	3

- (c) John replaced the 5g Iron ring with another 5g metal ring. He made sure that the metal contacts touched the 10g Iron ring.

When he closed the switch, he observed that duck B moved up but it did not move back down. Explain why. [2]

Please do not write in the margin.

Please do not write in the margin.

(Go on to the next page)

SCORE	2
-------	---

- 38 Meiling conducted an experiment by placing a 1 kg block on a flat surface and measured the amount of force needed to pull it along the surface using a spring balance.

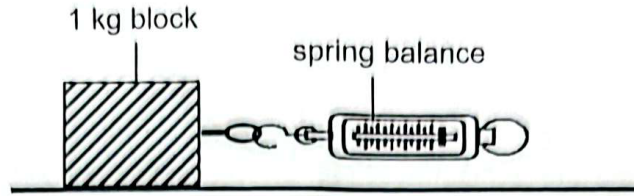

She repeated the experiment using three similar blocks that are of different masses and recorded the results in the graph.

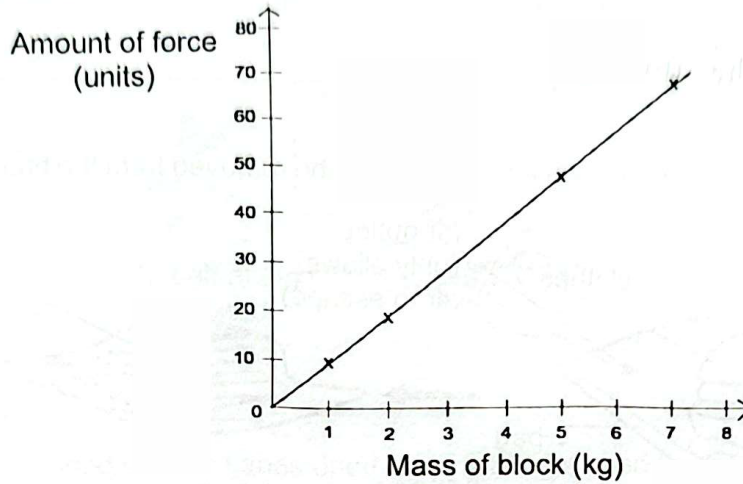

- (a) State what Meiling could conclude based on the results of her experiment. [1]

- (b) Meiling read in the news that the MRT trains kept breaking down frequently due to wear and tear of the train wheels. She also read that there was an increase in the number of passengers over a period of time.

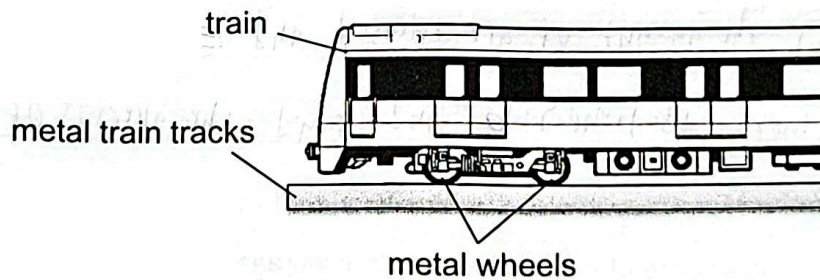

Explain how an increase in the number of passengers could cause frequent train breakdowns. [2]

(Go on to the next page)

SCORE	3

Please do not write in the margin.

Please do not write in the margin.

39 Siti packed some clothes into a bag and sealed it.

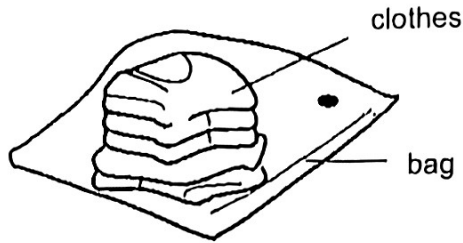

(a) Identify the state(s) of matter in the sealed bag. [1]

Siti wants to find out the mass of air that ~~was~~ can be removed from the bag by pressing down on the bag.

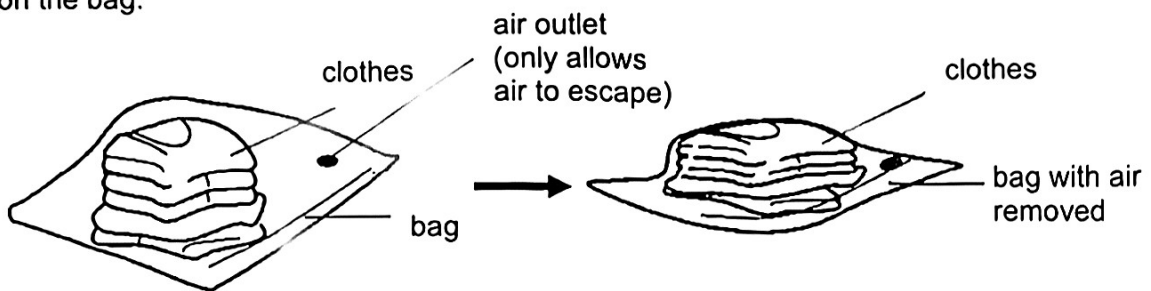

(b) Using an electronic balance, describe the steps she needs to take to find the mass of air that can be removed. [2]

(bii) Will the volume of the bag with clothes increase, decrease or remain the same after air is removed? Explain your answer using the physical property of air. [1]

Please do not write in the margin.

Please do not write in the margin.

(Go on to the next page)

SCORE	4
-------	---

40 (a) State what evaporation is. [1]

After washing his hands, Mr Tan placed his wet hands, in a clasped manner, under a wall-mounted hand dryer as shown. The hand dryer gives out hot air at a high speed.

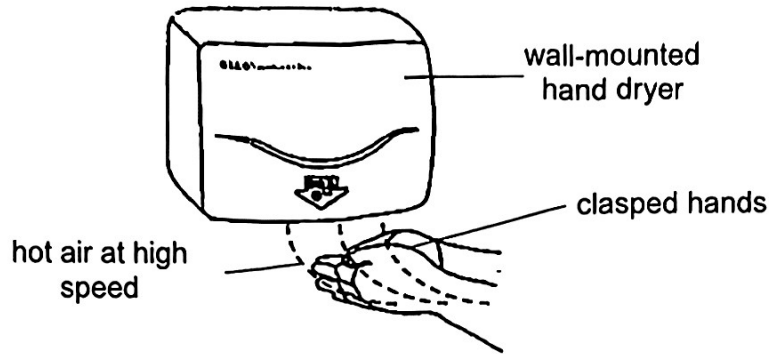

Mr Tan noticed that his hands dried faster when he used the hand dryer.

(bi) State two reasons why the hand dryer helps to dry his hands in a shorter time. [1]

(bii) Explain your answer in part (bi). [1]

(bii) Mr Tan spread out his hands instead of clasping them under the hand dryer. Will his hands take a longer or shorter time to dry? Explain your answer. [1]

End of Paper

(Go on to the next page)

SCORE	4
-------	---

Please do not write in the margin.

Please do not write in the margin.

ACS(J) P6 Preliminary Examination 2025 Suggested Answers

Booklet A

Q1	3	Q11	3	Q21	3
Q2	4	Q12	2	Q22	2
Q3	3	Q13	2	Q23	3
Q4	4	Q14	4	Q24	2
Q5	3	Q15	3	Q25	1
Q6	3	Q16	4	Q26	3
Q7	1	Q17	1	Q27	2
Q8	1	Q18	1	Q28	4
Q9	1	Q19	1		
Q10	3	Q20	4		

Booklet B

No.	Suggested Answers	Remarks
29a	His aim of the experiment is to find out how the pace of the music affects the heart rate (per minute).	
29b	As the pace of the music that children listen to increases, their heart rate increases.	
29c	He can repeat the experiment at least 3 times and take the average results to ensure consistency .	
30a	4	
30b	As the muddy water is washed into the pond, the mud from the mud blocks light from the Sun from reaching plant H. With less light trapped by H, the rate of photosynthesis decreases and less oxygen is produced over time.	
30c	Frog. Frog is an amphibian and it can take in oxygen	

	from the surrounding air using lungs unlike other organisms in the pond.	
31a	<p>Grassland: Monkey A. It has light-brown coloured thick fur that can camouflage and blend in with the yellow coloured grass better than B. A is less likely to be spotted by the predators, hence, it has a high chance of survival.</p> <p>Rainforest: Monkey B has a long tail that allows it to hang and swing from tall tree to tall tree to escape from predators more quickly, hence, it has a high chance of survival.</p>	
31b	The thick fur allows them to trap a layer of air. Air is a poor conductor of heat and reduces the heat lost from the body, thus keeping them warm.	
32a	Wind	
32bi	Flower D. It has stigma to receive pollen grains from the bees during pollination. It also has an ovary that develops into fruit after fertilisation. Flower E does not have both stigma and ovary.	
32bii	<p>The bees help to transfer pollen grains from the anthers of flower E to the stigma of flower D, thus, pollination can take place followed by fertilisation.</p> <p>The bees get nectar as a source of food from the flowers.</p>	
33a	His left hand gained heat from the hot coffee, making his hand feel warm. His right hand lost heat to the iced coffee, making his hand feel cold.	
33b	The clear plastic lid is transparent and allows light to pass through and lands on the coffee. The coffee then reflects the light into his eyes. The paper cup is opaque and does not allow any light to pass through, hence, he is unable to see through.	
33c	He can pour an equal amount of water at the same	

	<p>temperature into two cups. One of the cups has the plastic coating inside and the other cup does not have any plastic coating. He should observe if there is any water leaking out from the cup without a plastic coating.</p>	
34a		
34b	<p>When one of the bulbs fuses, the other bulb remains lit when it is switched on.</p>	
35a	<p>X: B Y: A</p>	
35b	<p>Any two The amount of water used at the start of the experiment</p>	<p>Do Not Accept Location of the surrounding (There are many</p>

	<p>The temperature of the surrounding</p> <p>The amount of wind in the surrounding</p>	<p>conditions/factors in the location, not all will affect the results of the experiment)</p>
35c	20°C	
35d	<p>Claim: Double-layered</p> <p>Evidence: The temperature of water increases slower for glass A when compared to B over 50 minutes.</p> <p>Reason: The layer of air trapped between the glass layers is a poor conductor of heat.</p> <p>Link: This reduces the heat gained from the warmer surrounding air outside the house into the inside of the house, thus, keeping the inside of the house cooler.</p>	
36a	Food he ate.	
36b	Kinetic Energy Electrical Energy Light Energy	
36c	<p>Any One</p> <p>It uses a renewable source of energy .</p> <p>It does not produce pollution.</p> <p>It does not produce harmful gases.</p>	
37a	<p>1st Marking Point: Duck A moves down</p> <p>When the switch is closed, electric current can flow through the closed circuit and the iron bar is magnetised to become an electromagnet. The electromagnet exerts a magnetic force of attraction on the iron ring under duck A, pulling duck A down.</p> <p>2nd Marking Point: Duck B moves down</p> <p>When duck B moves up and is not touching the metal contacts, electric current cannot flow through the open circuit. The electromagnet is demagnetised and it is no longer attracting iron ring under A. As the ring under B has more mass than the ring under A, more gravitational force acts on the ring under B,</p>	

	<p>pulling it down, causing duck B to move down.</p> <p>The cycle repeats.</p>	
37b	<p>Any one Increase the number of batteries (connected in series) Increase the number of coils of wire around iron bar</p>	<p>Do Not Accept Increase the mass of duck B (The ducks suggest keeping the same ducks)</p>
37c	<p>The metal ring is a magnet. When the duck B moves up, the new metal ring which is a magnet continues to exert a magnetic force of attraction on the magnetic iron bar. The force is stronger than the gravitational force exerted on the 10g metal ring under B.</p>	
38a	<p>As the mass of the block increases, the amount of force needed to pull it along the surface increases.</p>	
38b	<p>When the number of passengers on the train increases, the mass of the train with passengers increases. That results in a greater amount of frictional force between the metal wheels and metal train tracks. There is greater wear and tear on the wheels.</p>	
39a	<p>Solid and Gas</p>	
39bi	<p>Step 1, measure and record the mass of the bag with clothes using an electronic balance.</p> <p>Step 2, press down on the bag to remove as much air in the bag.</p> <p>Step 3, measure and record the mass of the bag with clothes with air removed using an electronic balance.</p> <p>Step 4, find the difference between the measurements in step 1 and 4 to find out the mass of air that can be removed.</p>	
39bii	<p>Decrease. Air is a matter and it occupies space. With less air, it occupies less space in the bag.</p>	

40a	Evaporation is a process where a liquid gains heat from a heat source to become gas at any temperature.	
40bi	The hot air provides more heat and more wind provided by the hot air moving at high speed.	
40bii	The water on his hands gained heat from the hot air and evaporated faster. The hot air moving at high speed provides wind to the water on his hands, causing the water to evaporate faster.	
40c	Shorter. When his hands are spread out, it increases the exposed surface area of the water on this hand and increases the rate of evaporation of water, causing more water on his hand to evaporate in a shorter time.	