

SA2

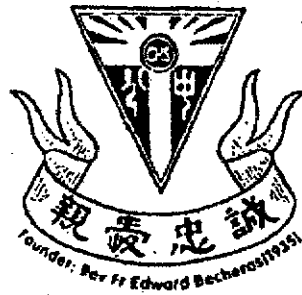

CATHOLIC HIGH SCHOOL
PRELIMINARY EXAMINATION (2021)
PRIMARY SIX
MATHEMATICS
PAPER 1
(BOOKLET A)

Name : _____ ()

Class : Primary 6 _____

Date : 20 August 2021

Total time for Booklet A and B : 1 hour

15 questions

20 marks

Parent's signature : _____

INSTRUCTIONS TO CANDIDATES

Do not turn over this page until you are told to do so.

Follow all instructions carefully.

Answer all questions.

Shade your answers in the Optical Answer Sheet (OAS) provided.

The use of calculators is **NOT** allowed.

Booklet A and B consist of 13 printed pages excluding the cover pages.

Questions 1 to 10 carry 1 mark each. Questions 11 to 15 carry 2 marks each. For each question, four options are given. One of them is the correct answer. Make your choice (1, 2, 3 or 4). Shade the oval (1, 2, 3 or 4) on the Optical Answer Sheet. All diagrams are not drawn to scale. (20 marks)

1. Which digit in 69.78 is in the tenths place?

- (1) 6
- (2) 7
- (3) 8
- (4) 9

2. Express 3050 cm in metres.

- (1) 3.5 m
- (2) 3.05 m
- (3) 30.5 m
- (4) 30.05 m

3. Mei paid \$2.50 for 50 stickers. How much did each sticker cost?

- (1) 5¢
- (2) 2¢
- (3) 20¢
- (4) 50¢

4. Which of the following is the likely mass of an oral digital thermometer?



- (1) 0.12 g
- (2) 1.2 g
- (3) 12 g
- (4) 120 g

5. Each figure below is made up of 1 square and 4 identical equilateral triangles. 2 of the triangles in each figure are shaded. Which figure has a line of symmetry?



(1)

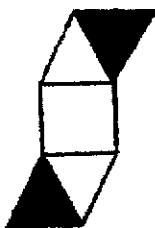

(2)



(3)

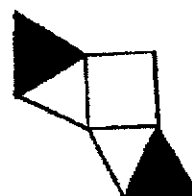

(4)

6. MN is a straight line.

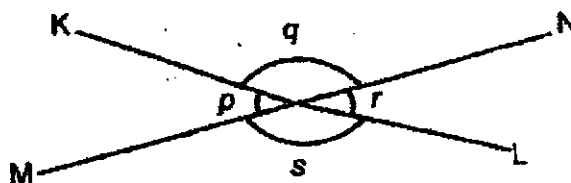

Which of the following is true?

- (1) $\angle p = \angle r$
 (2) $\angle q = \angle s$
 (3) $\angle r + \angle q = 180^\circ$
 (4) $\angle p + \angle q = 180^\circ$

7. A schedule of an on-line course is as shown. One activity leads to another without any break in between.

Start Time	Activity
2.30 p.m.	Zoom session
3.50 p.m.	Question-and-Answer session
4.25 p.m.	Closure

Mrs Lee was 5 minutes late for the Zoom session. She left 10 minutes before the end of the Question-and-Answer session. How long did Mrs Lee attend the on-line course?

- (1) 65 min
 (2) 70 min
 (3) 100 min
 (4) 105 min
-
8. Fann uses the recipe below to make biscuits.



Biscuit Recipe
(makes 9 pieces)

Flour : 150 g
 Butter : 100 g
 Sugar : 50 g

She has $\frac{1}{2}$ kg of flour, 420 g of butter and 110 g of sugar.
 What is the greatest number of pieces of biscuit she can make?

- (1) 18
 (2) 27
 (3) 36
 (4) 81
-

9. At a school, each pupil chose either Sports or Aesthetics as CCA. Figure 1 and Figure 2 show the pupils' choice for their CCA.

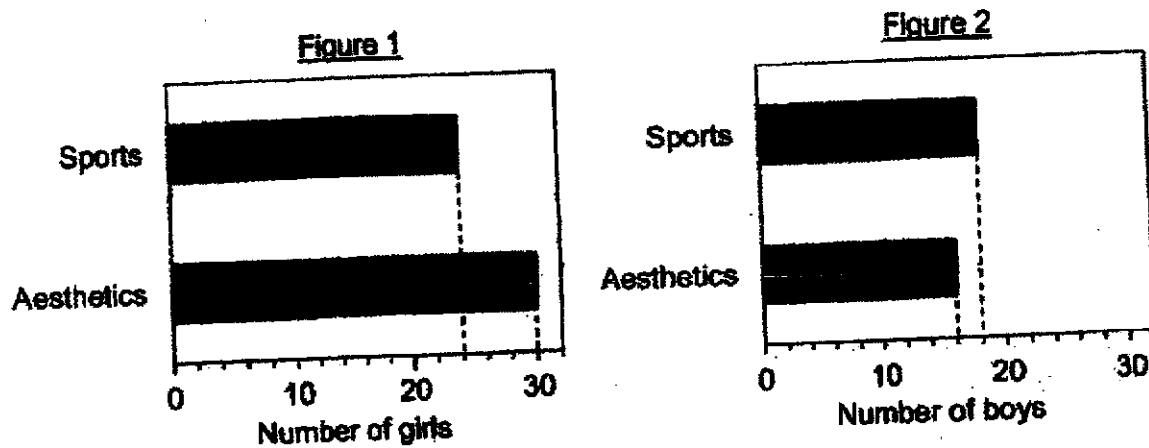

What is the difference in the number of pupils who chose Sports as CCA and the number of pupils who chose Aesthetics as CCA?

- (1) 25
 (2) 20
 (3) 7
 (4) 4
-
10. Which of the following fractions is smaller than $\frac{1}{4}$?

- (1) $\frac{9}{35}$
 (2) $\frac{7}{29}$
 (3) $\frac{6}{24}$
 (4) $\frac{4}{15}$

11.

	Tickets at \$8 each
	\$2 discount for every purchase of 4 tickets

What is the percentage discount for the purchase of 10 tickets?

- (1) 5%
- (2) 10%
- (3) 20%
- (4) 25%

12.

At a hawker centre, each table has either 3 or 5 chairs around it. The number of tables to the number of chairs is 7 : 25. What is the ratio of the number of tables with 5 chairs to that with 3 chairs?

- (1) 5 : 2
- (2) 2 : 5
- (3) 3 : 4
- (4) 4 : 3

13.

Gabriel rented a board game set and it was overdue when he returned it. The payment for the overdue board game set was based on the charges shown below.

First 7 days	20¢ per day
After the first 7 days	40¢ per day

He paid a total of \$3.80. How many days was the board game set overdue?

- (1) 6
- (2) 9
- (3) 13
- (4) 16

14. 25 people were asked to wrap a rice dumpling. The table below shows the number of people with the following times clocked.

Time clocked (s)	40	50	55	60	62	70	82
Number of people	4	2	3	7	3	4	2

The first 6 people who wrapped the rice dumpling the fastest were given a prize each. Daphne won a prize.

Which of the following statement(s) is/are true?

- A. 9 people needed at least 60 s to wrap a rice dumpling.
 B. The slowest time that Daphne could have clocked was 70 s.
 C. 36% of the people used less than 1 min to wrap a rice dumpling.

- (1) A only
 (2) C only
 (3) A and B only
 (4) B and C only

15. Felicia drew three circles, A, B and C, to form a figure. The ratio of the area of circle A to the area of circle B to the area of circle C is 1 : 9 : 4.
 $\frac{1}{4}$ of the area of circle A is shaded. What fraction of the figure is shaded?

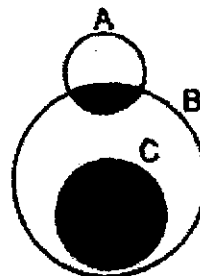

- (1) $\frac{17}{39}$
 (2) $\frac{20}{39}$
 (3) $\frac{17}{56}$
 (4) $\frac{35}{56}$

END OF BOOKLET A



CATHOLIC HIGH SCHOOL
PRELIMINARY EXAMINATION (2021)
PRIMARY SIX
MATHEMATICS
PAPER 1
(BOOKLET B)

Name : _____ ()

Class : Primary 6 _____

Date : 20 August 2021

Total time for Booklet A and B : 1 hour

15 questions

25 marks.

Parent's signature : _____

BOOKLET A	20
BOOKLET B	25
Total Marks	45

INSTRUCTIONS TO CANDIDATES

Do not turn over this page until you are told to do so.

Follow all instructions carefully.

Answer all questions.

Write your answers in this booklet.

The use of calculators is **NOT** allowed.

Booklet A and B consist of 13 printed pages excluding the cover pages.

Questions 16 to 20 carry 1 mark each. Write your answers in the spaces provided. For questions which require units, give your answers in the units stated. All diagrams are not drawn to scale. (5 marks)

Do not write
in this space

16. Measure and write down the size of $\angle x$ in the figure.

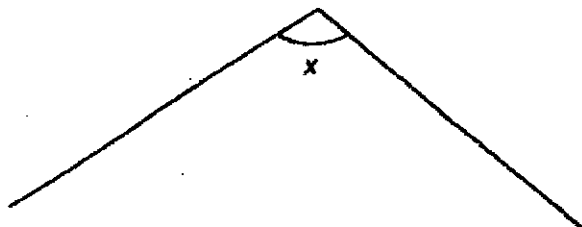

Ans: _____

17. Find the value of $4 + \frac{3}{5}$.
Give your answer as a mixed number.

Ans: _____

18. Maureen gave the cashier a \$50 note to pay for a T-shirt. The cashier did not have any coins as small change, so Maureen gave her another 30 cents and received a \$10 note as change. What was the cost of the T-shirt?

Ans: \$ _____

Refer to the figure below to answer questions 19 and 20.

Six roads and three landmarks on a map are shown in the square grid. The roads are roads A, B, C, D, E and F. The three landmarks are petrol kiosk, airport, car park.

Do not write in this space

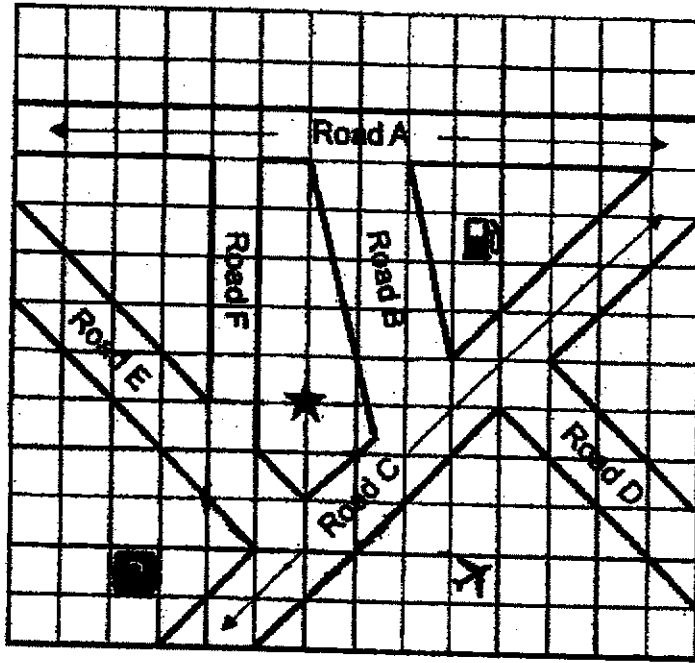

Landmarks



19. Name the two roads that are parallel to each other.

Ans: _____ and _____

20. Mingfa was at the position marked '*'. After turning 90° anti-clockwise, he faced the airport. Which landmark was he facing before the turn?

Ans: _____

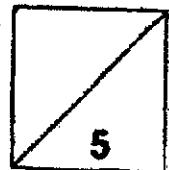

Total marks for questions 16 to 20

Questions 21 to 30 carry 2 marks each. Show your working clearly and write your answers in the spaces provided. For questions which require units, give your answers in the units stated. All diagrams are not drawn to scale.

(20 marks)

Do not write
in this space

21. Find the value of $2 + 7$.
Give your answer as a decimal, correct to 1 decimal place.

Ans: _____

22. Use all the digits 8, 0, 9, 2 to form the

- (a) smallest multiple of 5.
(b) number closest to 9000.

Ans: (a) _____

(b) _____

23. Some books were shared equally among 40 children at first. When 10 of them gave up their share of the books, the rest received 2 extra books each. How many books did each child get at first?

Do not write
in this space

Ans: _____

24. Darryl baked some cookies. He sold $\frac{3}{4}$ of the cookies at a fund raising event and ate $\frac{1}{8}$ of the remaining cookies. He was left with 35 cookies. How many cookies did he bake?

Ans: _____

25. In the square grid below, ABC is a triangle.

(a) Measure the side AB of the triangle and write down its length to the nearest cm.

(b) Draw the corresponding height of the triangle with the side AC as its base.

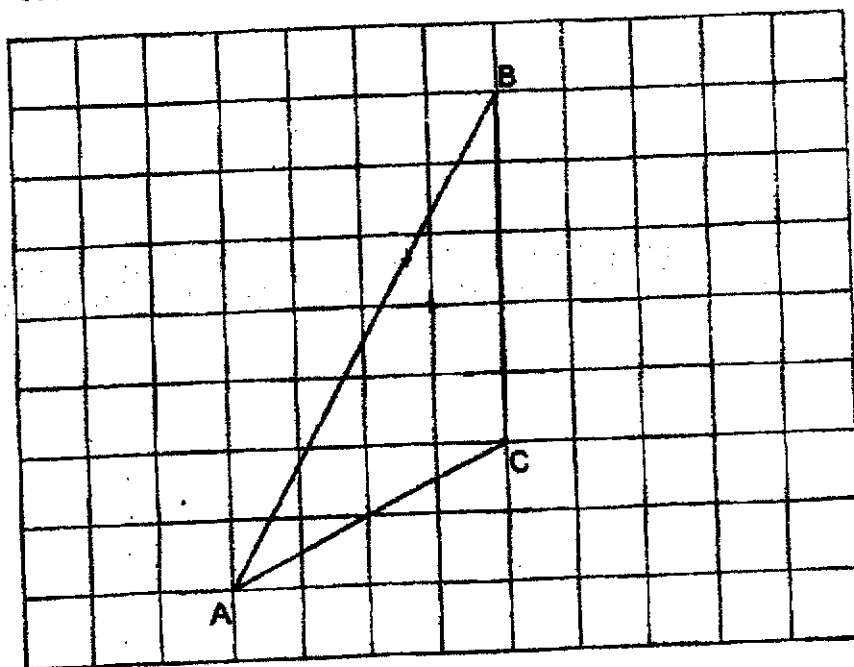

Ans: _____ cm

26.

The number line below is marked at equal intervals.
What is the value of X? Give your answer as a fraction in its simplest form.

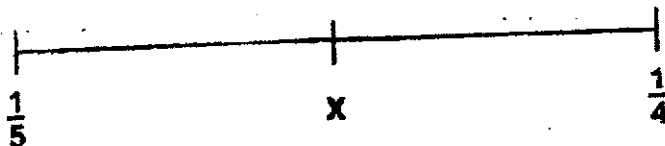

Ans: _____

27. Kenneth deposits \$8200 in a bank for one year. The interest rate is 2% per year. What is the total amount of money he will have in the bank at the end of one year?

Do not write in this space

Ans: \$ _____

28. White squares and black squares are used to form figures that follow a pattern. The first three figures are shown below.

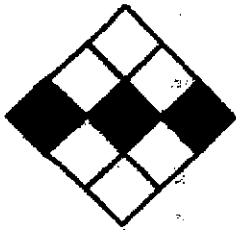

Figure 1

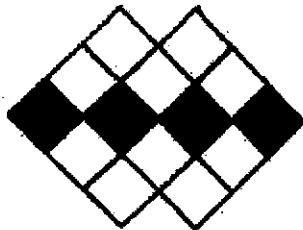

Figure 2

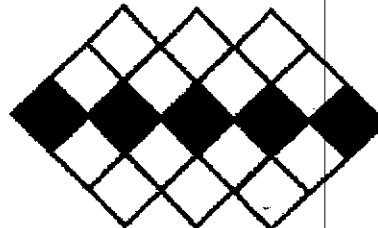

Figure 3

How many white squares are used to form Figure 20?

Ans: _____

29. Kai glues sixteen 1-cm cubes to form the solid shown.



He puts three such solids into an empty rectangular glass box as shown. What is the capacity of the glass box?

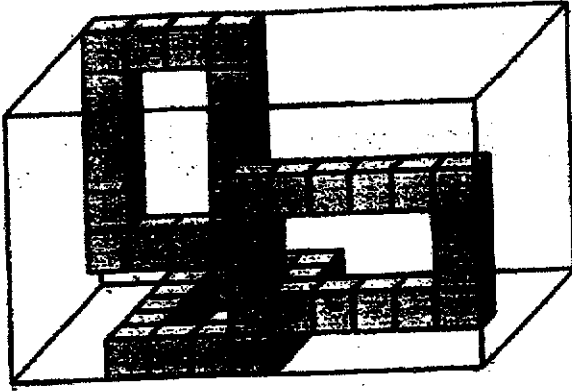

Ans: _____ cm³

30. Owen bought some pears, apples and oranges. The ratio of the number of pears to the number of apples was 8 : 11. There were 36 more oranges than pears and 12 more oranges than apples. How many apples did Owen buy?

Ans: _____

Total marks for questions 21 to 30

END OF BOOKLET B
END OF PAPER 1



CATHOLIC HIGH SCHOOL
PRELIMINARY EXAMINATION (2021)
PRIMARY SIX
MATHEMATICS
PAPER 2

Name : _____ ()

Class : Primary 6 _____

Date : 20 August 2021

Total time : 1 h 30 min

17 questions

55 marks

Parent's signature : _____

PAPER 1 BOOKLET A	20
PAPER 1 BOOKLET B	25
PAPER 2	55
Total Marks	100

INSTRUCTIONS TO CANDIDATES

Do not turn over this page until you are told to do so.

Follow all instructions carefully.

Answer all questions.

Write your answers in this booklet.

The use of an approved calculator is expected, where appropriate.

This booklet consists of 16 printed pages excluding the cover pages.

Questions 1 to 5 carry 2 marks each. Show your working clearly in the space below each question and write your answers in the spaces provided. For questions which require units, give your answers in the units stated. All diagrams are not drawn to scale. (10 marks)

Do not write in this space

1. The square grid shows the position of points A, B, C, D, F and G.

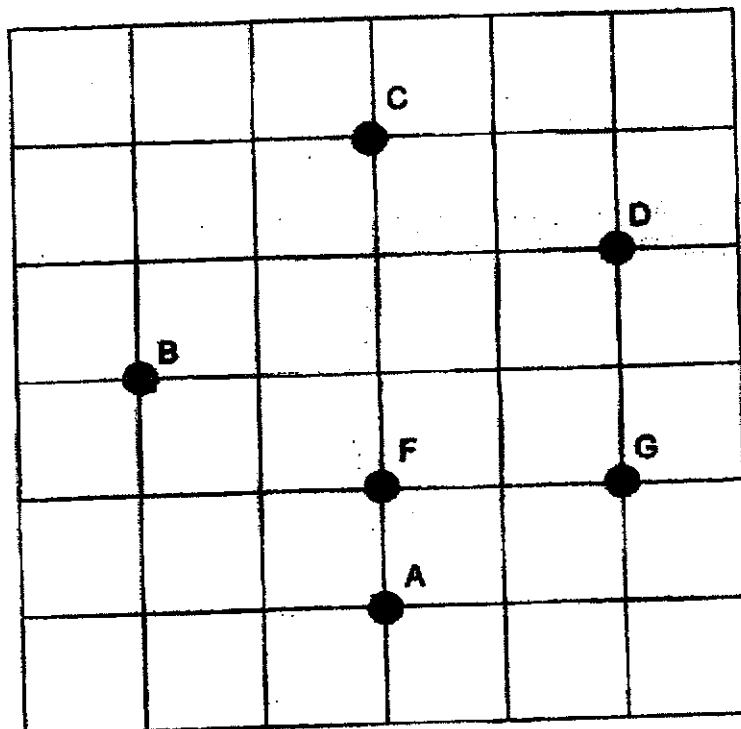

In the square grid,

- (a) point _____ is east of point _____.
- (b) point _____ is north-west of point _____.



2. The total cost of 2 pens and a book is \$55. The cost of a pen is $\frac{2}{7}$ of the cost of a book. What is the cost of a book?

Ans: \$ _____

3. In the figure, ABCD is a rectangle. DEGH is a square. Point H lies on the line BC. $\angle ABG = 20^\circ$ and $\angle BHG = 17^\circ$.

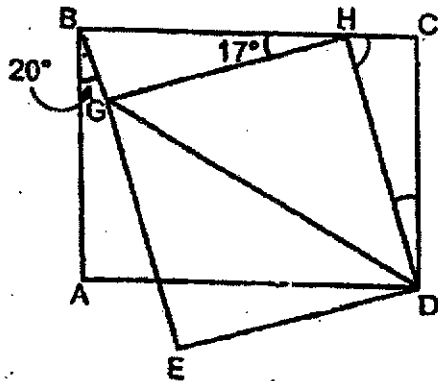

Each of the statements below is either true, false or not possible to tell from the information given. For each statement, put a tick (✓) to indicate your answer.

Statement	True	False	Not possible to tell
$\angle EGD = 45^\circ$			
BHDG is a trapezium.			
$\angle BHG = \angle CDH$			

4. During a promotion, a shop gave 6 free stickers for every 50 stickers bought. Don bought some stickers and got 210 stickers altogether. How many stickers would Don get for the same amount paid without the promotion?

Do not write
in this space

Ans: _____

5. The total volume of grape juice in barrel A and barrel B is 7.4 L. The total volume of grape juice in barrel B and barrel C is 9.7 L. The volume of grape juice in barrel C is twice the volume of grape juice in barrel A. What is the average volume of grape juice in the three barrels?

Ans: _____ L

For questions 6 to 17, show your working clearly in the space provided for each question and write your answers in the spaces provided. The number of marks available is shown in brackets [] at the end of each question or part-question. (45 marks)

Do not write in this space

6. Wendy had a sum of money which she spent on transport, clothes, meals and games. The table shows the percentage of the money spent on each item.

Items	Percentage of money spent
Transport	25%
Clothes	20%
Meals	40%
Games	15%

This is also represented by a bar graph but the amount of money spent for each item is not shown on the scale. The bar for the amount of money spent on games is also not drawn.

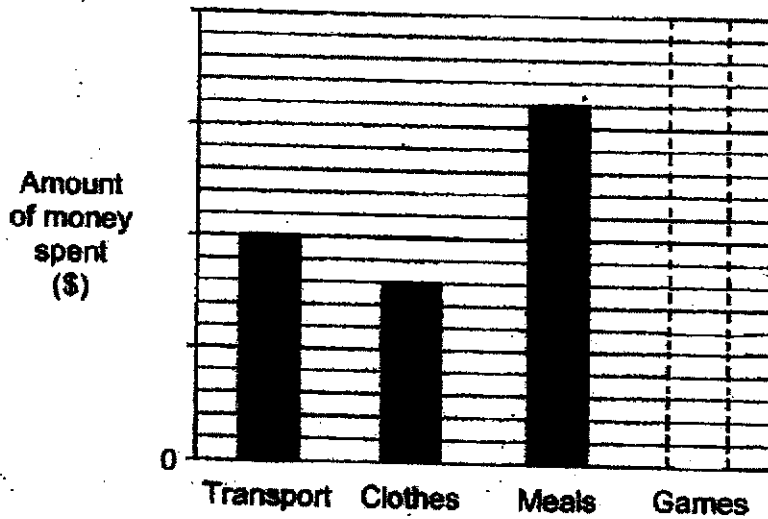

[2]

- (a) What was the ratio of the amount of money spent on transport to the amount of money spent on clothes to the amount of money spent on meals? Give your answer in the simplest form.
- (b) Draw the bar that represents the amount of money Wendy spent on games.

Ans: (a) _____ [1]



7. Jack has \$ y for pocket money. Krishnan has thrice as much pocket money as Jack. Latiff has \$10 less than Krishnan.

Do not write
in this space

- (a) What is the total amount of pocket money the three boys have in terms of y ?
- (b) The sum of Latiff's pocket money and Jack's pocket money is \$50. What is the value of y ?

Ans: (a) _____ [1]

(b) _____ [2]



8. In the figure below, ABC is an equilateral triangle and CDE is an isosceles triangle with $DC = DE$. Point E lies on the side AB of the equilateral triangle. $\angle CDE = 36^\circ$ and $\angle ECB = 321^\circ$.

Do not write in this space

Find $\angle EFC$.

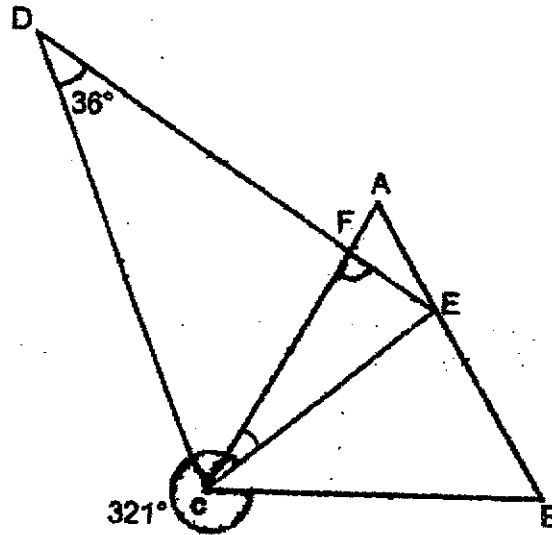

Ans: _____ [3]

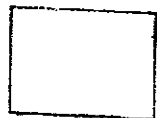

9.

The figure shows a square ABDE and a right-angled triangle BCD. AFC is a straight line. DC is twice the length of ED. The area of triangle ABF is $\frac{1}{6}$ the area of the square. The area of triangle BCF is 48 cm^2 . What is the length of each side of square ABDE?

Do not write in this space

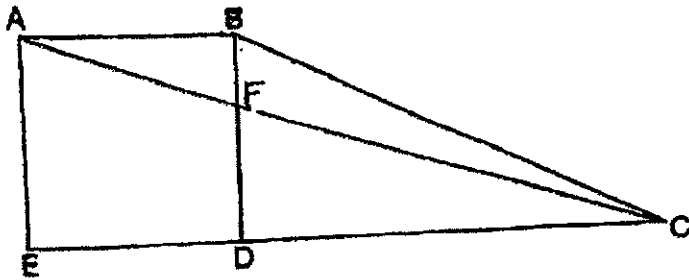

Ans: _____ [3]



10. A square hall ABCD is fitted with a semi-circle stage as shown. The shaded stage has the side DC of the hall as its diameter and a perimeter of 40 m. The perimeter of the unshaded part of the hall is 64 m. What is the area of the shaded stage in terms of π ?

Do not write in this space

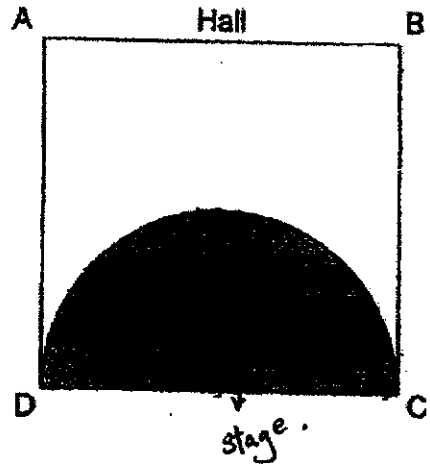

Ans: _____ [3]



11. A box contained apples and pears. $\frac{4}{5}$ of the fruits were apples and the rest were pears. After $\frac{3}{4}$ of the fruits were removed, there were $\frac{1}{8}$ of the apples and 30 pears left. How many fruits were there in the box at first?

Do not write
in this space

Ans: _____ [4]



12. Cayden drained water from Tank A and Tank B using Tap A and Tap B respectively. For Tank A, he turned on Tap A partially at 11 00 and then fully 4 minutes later. For Tank B, he turned on Tap B fully at 11 04. He left both taps on until water was completely drained from each tank.

The graphs below show the volume of water left in each tank for the period from 11 00 to 11 12.

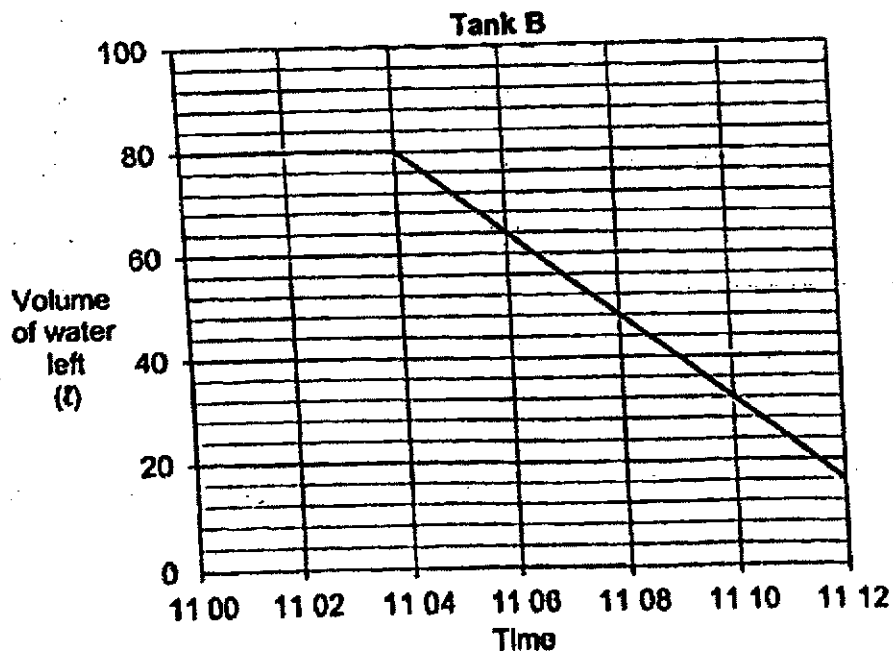
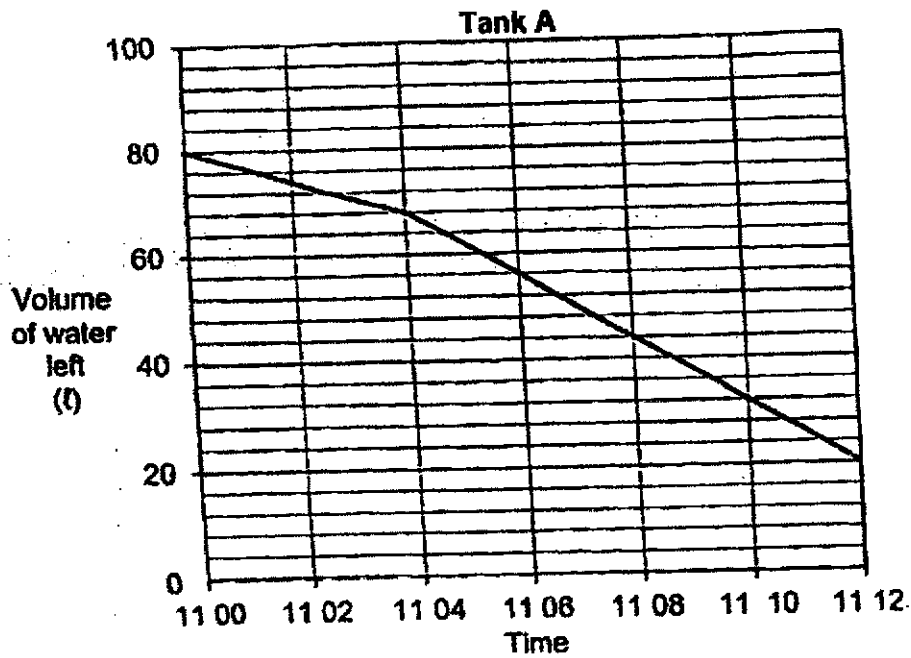

- (a) At what time was the volume of water left the same in both the tanks?
- (b) Starting from 11 04, which tank, A or B, had a slower rate of drainage? How much water was drained from this tank?
- (c) How many minutes did it take for Tank B to be completely drained of water after Tap B was turned on?

to from 11:04 to 11:12
^

Ans: (a) _____ [1]
(b) Tank _____ [2]
(c) _____ [1]



13. Jeremy had a piece of paper ABCD in the shape of a parallelogram. He folded it along the line EF as shown below.

Do not write in this space

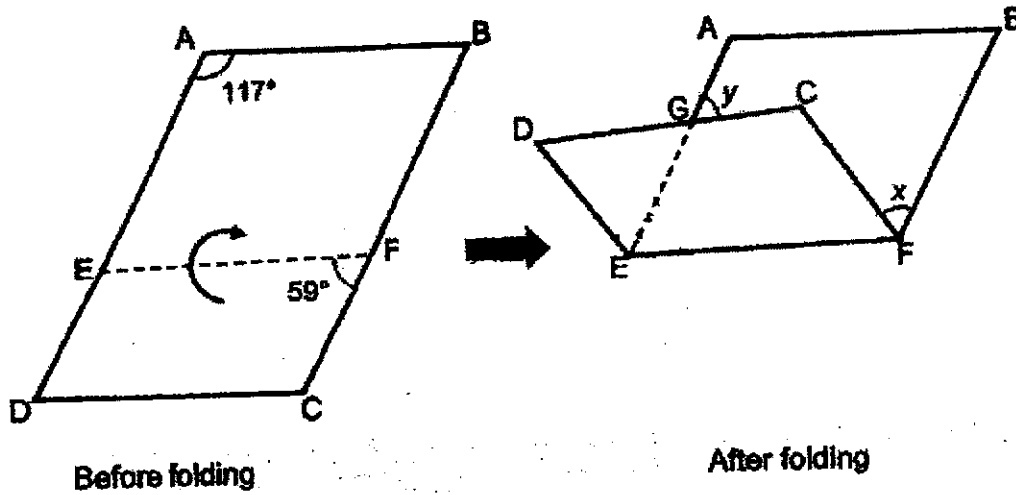

- (a) Find $\angle x$.
- (b) Find $\angle y$.

Ans: (a) _____ [1]
 (b) _____ [3]

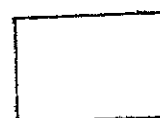

14. Mrs Lim prepared 160 chicken wings and some nuggets for a party. At one point during the party, an equal number of chicken wings and nuggets were eaten. 25% of the chicken wings and 20% of the nuggets were left. She then increased the number of chicken wings. After that, there was a total of 65 chicken wings.

Do not write in this space.

- (a) How many nuggets did Mrs Lim prepare for the party?
- (b) What was the percentage increase in the number of chicken wings after the same number of chicken wings and nuggets were eaten?

Ans: (a) _____ [3]

(b) _____ [2]



15. Benson uses some wire to make the figure as shown. He made 2 identical wire structures and joined them with a piece of wire AB. Each wire structure was formed by a large semi-circle, a small semi-circle and 2 straight lines.

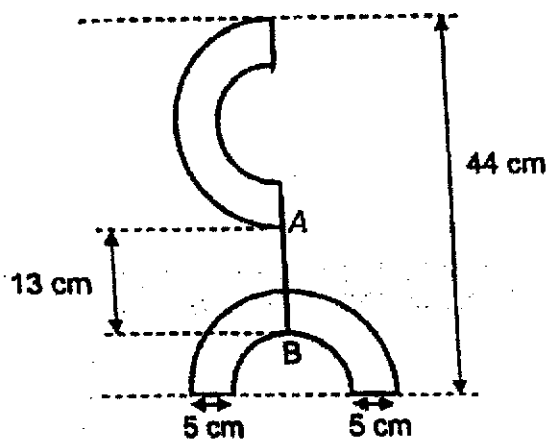

- (a) What is the radius of a small semi-circle?
- (b) Find the length of wire used to make the figure.
Take $\pi = 3.14$

Ans: (a) _____ [2]

(b) _____ [2]

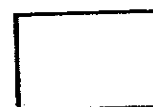

16. Cathy and David each had a piece of dough of the same mass at first. Cathy divided her dough into equal parts of mass 90 g and for each part, she used it to bake 2 star-shaped cookies. David also divided his dough into equal parts of mass 150 g and for each part he used it to bake 6 heart-shaped cookies. There were 72 more heart-shaped cookies than star-shaped cookies in the end.

Do not write
in this space



- (a) How many cookies did Cathy and David bake altogether?
- (b) David packed his cookies into 22 boxes. Some boxes contained 5 cookies while the rest contained 9 cookies. How many boxes contained 9 cookies?

Ans: (a) _____ [3]

(b) _____ [2]



17. Mr Lee tries to cover a square floor with as many rectangular tiles of the same size as possible that follow a pattern as shown. The tiles are either white or grey.

Do not write
in this space

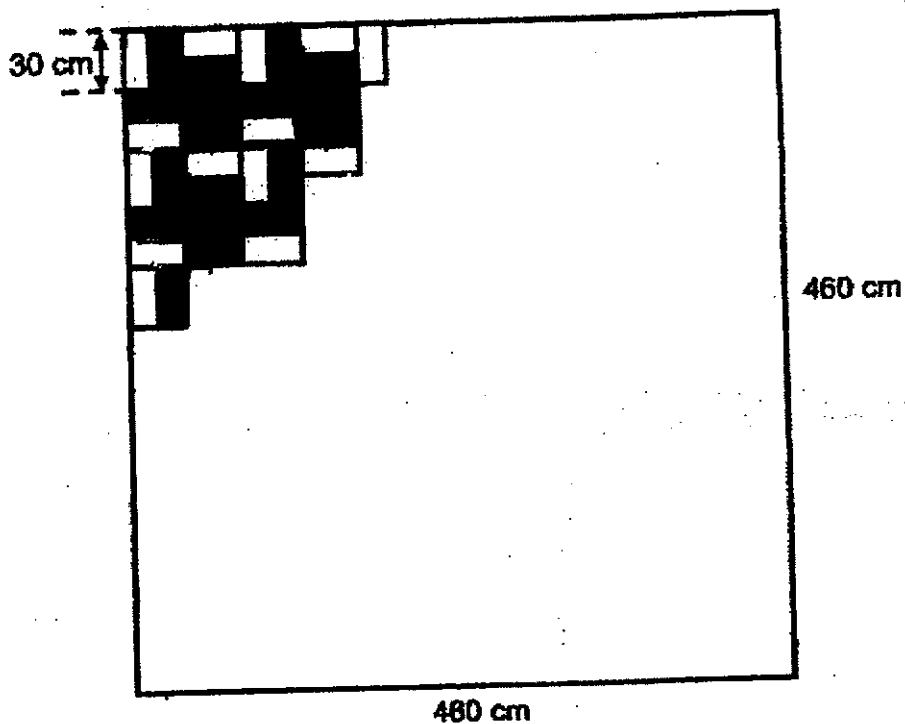

- (a) What is the greatest possible number of tiles that Mr Lee can use to cover the floor?
- (b) Of the greatest possible number of tiles that Mr Lee can use to cover the floor, how many of the tiles are grey tiles?

Ans: (a) _____ [2]

(b) _____ [2]



END OF PAPER 2

ANSWER KEY

YEAR : 2021
LEVEL : PRIMARY 6
SCHOOL : CATHOLIC HIGH
SUBJECT : MATHEMATICS
TERM : PRELIMINARY

BOOKLET A (PAPER 1)

Q1	2	Q2	3	Q3	1	Q4	3	Q5	4
Q6	4	Q7	3	Q8	1	Q9	4	Q10	2
Q11	1	Q12	2	Q13	3	Q14	2	Q15	1

BOOKLET B (PAPER 1)

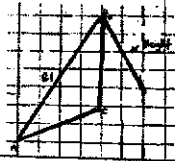
Q16	106°	Q17	$4 \times \frac{5}{3} = \frac{20}{3} = 6\frac{2}{3}$
Q18	$50 + 0.30 - 10 = \$40.30$	Q19	E and D
Q20	Car Park	Q21	$\frac{2}{7} \approx 0.28 \approx 0.3$
Q22	a) 2 8 9 0 b) 9 0 2 8	Q23	$30 \times 2 = 60$ $60 \div 10 = 6$
Q24	$1u = 35 \div 5 = 7$ $24u = 24 \times 7 = 168$ cookies	Q25	a) 8cm b) 
Q26	$\frac{1}{4} - \frac{1}{5} = \frac{5}{20} - \frac{4}{20}$ $= \frac{1}{20} \div 2 = \frac{1}{40}$ $\frac{1}{5} + \frac{1}{40} = \frac{8}{40} + \frac{1}{40} = \frac{9}{40}$	Q27	One year = $8200 \times \frac{102}{100} = 8364$
Q28	Fig 20 = $20 \times 4 + 2 = 82$	Q29	Capacity = $11 \times 6 \times 7 = 462 \text{ cm}^3$
Q30	$3u = 36 - 12 = 24$ $1u = 24 \div 3 = 8$ $11u = 8 \times 11 = 88$ apples		

PAPER 2

Q1	<p>a) Point G is east of point F</p> <p>b) Point B is north-west of point A.</p>	Q2	<p>Book = $7u$</p> <p>Pen = $2u$</p> <p>$4u + 7u = 55$</p> <p>$1u = 55 \div 11 = 5$</p> <p>$7u = 7 \times 5 = 35$</p>
Q3	<p>$\angle EGD = 45^\circ$ (True)</p> <p>BHDG is a trapezium. (False)</p> <p>$\angle BHG = \angle CDH$. (True)</p>	Q4	<p>1 set = $50 + 6 = 56$</p> <p>$210 \div 56 = 3k42$</p> <p>Get without promo = $50 \times 3 + 42$</p> <p>=192 stickers</p>
Q5	<p>$A + B = 7.4$</p> <p>$B + C = 9.7$</p> <p>$C - A = 9.7 - 7.4 = 2.3$</p> <p>$A = 2.3$</p> <p>$C = 2.3 \times 2 = 4.6$</p> <p>$B = 7.4 - 2.3 = 5.1$</p> <p>Average = $(2.3 + 4.6 + 5.1) \div 3 = 4L$</p>	Q6	<p>a) $10 : 8 : 16$</p> <p>$5 : 4 : 8$</p> <p>b) $1u = 2.5\% M$</p> <p>Games = $15\% \div 2.5\%$</p> <p>=6</p>
Q7	<p>a) $J = Y$</p> <p>$K = 3y$</p> <p>$L = 3y - 10$</p> <p>Total = $Y + 3y + 3y - 10$</p> <p>= $\\$(7y - 10)$</p> <p>b) $Y + 3y - 10 = 50$</p> <p>$4y = 60$</p> <p>$Y = 60 \div 4 = \\$15$</p>	Q8	<p>$\angle DEC = \frac{180^\circ - 36^\circ}{2} = 72^\circ$</p> <p>$\angle ECF = 321^\circ + 60^\circ - 360^\circ = 21^\circ$</p> <p>$\angle EFC = 180^\circ - 72^\circ - 21^\circ = 87^\circ$</p>
Q9	<p>$ABF = 1u \times 1u \times \frac{1}{6} = \frac{1u^2}{6}$</p> <p>$\frac{1u^2}{6} + 48 = 1u \times 1u \times \frac{1}{2}$</p> <p>$(\frac{1u^2}{6} + 48) = (\frac{1u^2}{2})$</p> <p>$1u^2 + 288 = 3u^2$</p> <p>$2u^2 = 288$</p> <p>$1u^2 = 288 \div 2 = 144$</p> <p>$1u = \sqrt{144} = 12\text{cm}$</p>	Q10	<p>$X + Y = 40$</p> <p>$3y + X = 64$</p> <p>$2Y = 64 - 40 = 24$</p> <p>$Y = 24 \div 2 = 12$</p> <p>Radius = $12 \div 2 = 6$</p> <p>Area = $6 \times 6 \times \frac{1}{2} \times \pi = (18\pi)m^2$</p>
Q11	<p>Apple removed = $8u - 1u = 7u$</p> <p>Pears removed = $7.5u - 7u = 0.5u$</p> <p>Pears (left) = $2u - 0.5u = 1.5u$</p> <p>$1.5u = 30$</p> <p>$1u = 30 \div 1.5 = 20$</p> <p>$10u = 20 \times 10 = 200$</p>	Q12	<p>a) 11:10</p> <p>b) Drained = $68 - 20 = 48$</p> <p>$8\text{min} - 48L \div 8$</p> <p>$1\text{min} - 6L$</p> <p>ANS : Tank A. 6L</p> <p>c) 10 minutes</p>

Q13	<p>a) $\angle X = 180^\circ - 59^\circ - 59^\circ = 62^\circ$ b) $\angle ABF = 180^\circ - 117^\circ = 63^\circ$ $360^\circ - 117^\circ = 243^\circ$ $\angle Y = 540^\circ - 243^\circ - 62^\circ - 117^\circ - 63^\circ = 55^\circ$</p>	Q14	<p>a) $16u = 160$ $1u = 160 \div 16 = 10$ $15u = 15 \times 10 = 150$ b) $4u = 4 \times 10 = 40$ Increase = $65 - 40 = 25$ Percentage = $\frac{25}{40} \times 100\%$ = 62.5%</p>
Q15	<p>a) Small radius = $44 - 13 - 5 - 5 = 21$ $21 \div 3 = 7$ b) Diameter (small) = $7 \times 2 = 14$ Diameter (big) = $14 + 5 + 5 = 24$ Length = $24 \times \pi$ $3.14 + 14 \times 3.14 + 5 \times 4 + 13$ = 152.32 cm</p>	Q16	<p>a) $45x = 25(x + 72)$ $45x = 25x + 1800$ $20x = 1800$ $X = 1800 \div 20 = 90$ $X + 72 = 90 + 72 = 162$ = 252 cookies b) $X + 72 = 90 + 72 = 162$ Assume all contained 5 cookies Total = $22 \times 5 = 110$ Extra = $162 - 110 = 52$ Diff = $9 - 5 = 4$ 9 cookies = $52 \div 4$ = 13 boxes</p>
Q17	<p>a) Breath of tile = $30 \div 2 = 15$ 1 set = 2 tile No of sets on length = $460 \div 30 = 15R10$ No of sets = $15 \times 15 = 225$ No of tiles = $225 \times 2 = 450$ b) Set A = $15 \times 2 \div 2$ = $30 \div 2 = 15$ Grey tiles in set B = $1 \times 8 + 7 \times 2 = 22$ 8 set A = $15 \times 8 = 120$ 7 set B = $22 \times 7 = 154$ Total = $154 + 120 = 274$ tiles</p>		

