



CATHOLIC HIGH SCHOOL
PRELIMINARY EXAMINATION (2025)
PRIMARY SIX
MATHEMATICS
PAPER 1
(BOOKLET A)

Name : _____ ()

Class : Primary 6 _____

Date : 20 August 2025

Total time for Booklet A and B : 1 hour

15 questions

20 marks

Parent's signature : _____

INSTRUCTIONS TO CANDIDATES

Do not turn over this page until you are told to do so.

Follow all instructions carefully.

Answer all questions.

Shade your answers in the Optical Answer Sheet (OAS) provided.

The use of calculators is **NOT** allowed.

This booklet consists of 8 printed pages.

Questions 1 to 10 carry 1 mark each. Questions 11 to 15 carry 2 marks each. For each question, four options are given. One of them is the correct answer. Make your choice (1, 2, 3 or 4). Shade the oval (1, 2, 3 or 4) on the Optical Answer Sheet. All diagrams are not drawn to scale. (20 marks)

1. Which of the following decimals is the smallest?

- (1) 0.15
 - (2) 0.51
 - (3) 0.105
 - (4) 0.501
-

2. Which of the following is the same as 2040 cm?

- (1) 0.24 m
 - (2) 2.04 m
 - (3) 2 m 40 cm
 - (4) 20 m 40 cm
-

3. Which of the following shows $\frac{1}{5}$ of the figure shaded?

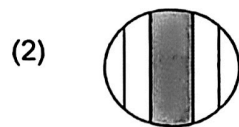
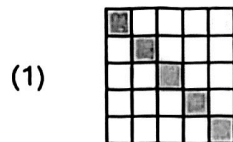

4. Which of the following is likely to be the length of a road bicycle?

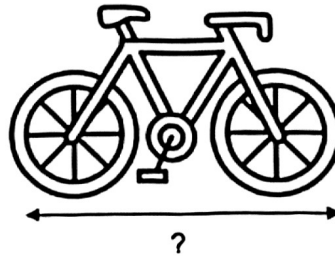

- (1) 17 cm
- (2) 170 cm
- (3) 17 m
- (4) 170 m

-
5. In the number line, what is the mixed number represented by A?

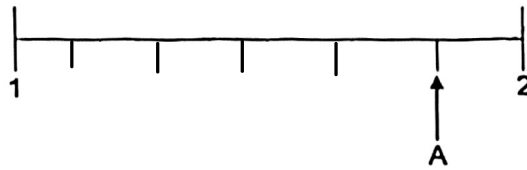

- (1) $1\frac{2}{3}$
- (2) $1\frac{3}{4}$
- (3) $1\frac{5}{6}$
- (4) $1\frac{6}{7}$

6. Rachel watched a movie at the cinema. The movie lasted for 2 h 15 min. After the movie ended, she walked 25 minutes to reach her home. She reached home at 6.55 p.m. What time did the movie start?

- (1) 4.15 p.m.
 - (2) 4.40 p.m.
 - (3) 7.20 p.m.
 - (4) 9.35 p.m.
-

7. Which of the following is a net of a cuboid?

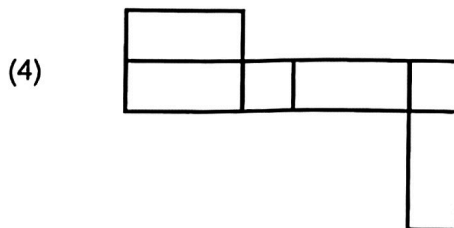
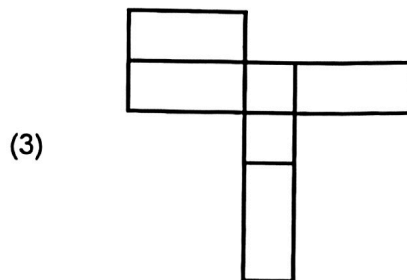
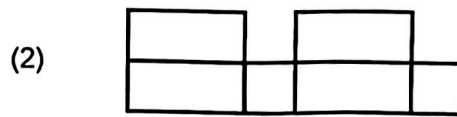
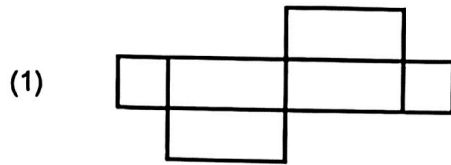

8. Which line in the square grid is perpendicular to BC?

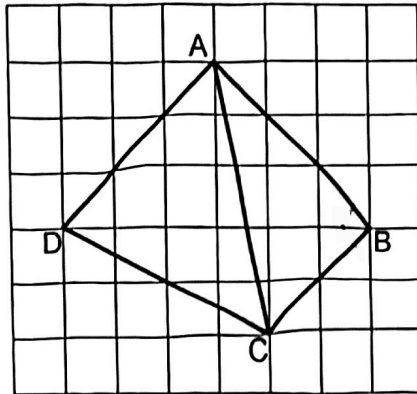

- (1) AC
- (2) BA
- (3) CD
- (4) DA

-
9. The square grid shows the position of 5 landmarks A, B, C, D and E.

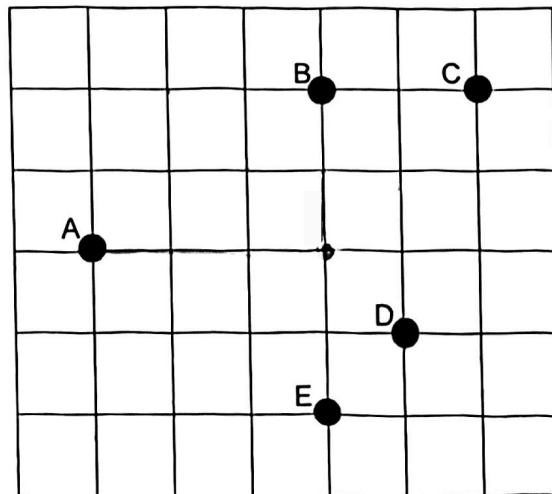

Julian is standing at a location north-west of landmark D and east of landmark A. In what direction is landmark C from Julian?

- (1) North-east
- (2) North-west
- (3) South-east
- (4) South-west

10. The pie chart shows the number of pupils taking part in various activities at a sports carnival. The same information is shown in a bar graph, but the names of the activities are not shown on the bar graph.

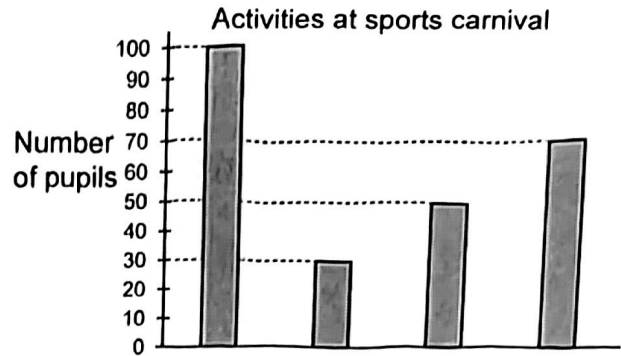

How many pupils took part in Soccer and Hockey altogether?

- (1) 120
 (2) 130
 (3) 150
 (4) 170
-
11. In the figure, FCEB and DGE are straight lines. ABC is an equilateral triangle. $DGE = FCE$ and $\angle CFD = 70^\circ$. Find $\angle CGE$.

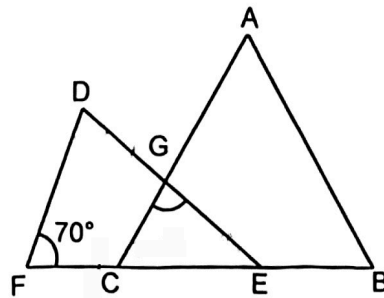

- (1) 40°
 (2) 80°
 (3) 100°
 (4) 140°

12. Alex and Ben had \$190 altogether at first. After Alex gave Ben \$30, Alex had \$40 more than Ben. How much did Ben have at first?

- (1) \$45
- (2) \$75
- (3) \$120
- (4) \$160

-
13. Arrange these volumes from the smallest to the largest.

2.25 l	$2\frac{2}{5} \text{ l}$	$2 \text{ l } 225 \text{ ml}$
------------------	--------------------------	-------------------------------

Smallest

Largest

- | | | |
|------------------------------|------------|--------------------------|
| (1) $2\frac{2}{5} \text{ l}$ | 2.25 l | 2 l 225 ml |
| (2) $2\frac{2}{5} \text{ l}$ | 2 l 225 ml | 2.25 l |
| (3) 2 l 225 ml | 2.25 l | $2\frac{2}{5} \text{ l}$ |
| (4) 2.25 l | 2 l 225 ml | $2\frac{2}{5} \text{ l}$ |

-
14. The figure is made up of one big semicircle and a small semicircle. The large semicircle with centre O has a radius of 6 cm. Find the perimeter of the figure. Leave your answer in terms of π .

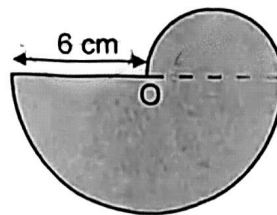

- ~~(1)~~ $6\pi \text{ cm}$
- ~~(2)~~ $9\pi \text{ cm}$
- (3) $(6\pi + 6) \text{ cm}$
- (4) $(9\pi + 6) \text{ cm}$

15. Joe baked some chocolate muffins and vanilla muffins. He sold an equal number of chocolate muffins and vanilla muffins. He had $\frac{3}{4}$ of the vanilla muffins and $\frac{3}{7}$ of the chocolate muffins left. What fraction of the muffins were sold?

(1) $\frac{5}{28}$

(2) $\frac{8}{23}$

(3) $\frac{23}{28}$

(4) $\frac{15}{23}$

END OF BOOKLET A

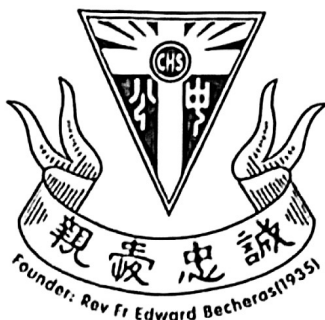

CATHOLIC HIGH SCHOOL
PRELIMINARY EXAMINATION (2025)
PRIMARY SIX
MATHEMATICS
PAPER 1
(BOOKLET B)

Name : _____ ()

Class : Primary 6 _____

Date : 20 August 2025

Total time for Booklet A and B : 1 hour

15 questions

25 marks

Parent's signature : _____

BOOKLET A	20
BOOKLET B	25
Total Marks	45

INSTRUCTIONS TO CANDIDATES

Do not turn over this page until you are told to do so.

Follow all instructions carefully.

Answer all questions.

Write your answers in this booklet.

The use of calculators is **NOT** allowed.

This booklet consists of 9 printed pages and 1 blank page.

Questions 16 to 20 carry 1 mark each. Write your answers in the spaces provided. For questions which require units, give your answers in the units stated. All diagrams are not drawn to scale. (5 marks)

Do not write in this space

16. Write three million, six thousand and forty in numerals.

Ans: _____

17. Round 39 470 to the nearest thousand

Ans: _____

18. Find the value of $\frac{3}{8} \div 18$
Give your answer as a fraction in the simplest form.

Ans: _____

19. Find the value of $3w - 9 + \frac{w}{4}$ when $w = 8$.

Do not write
in this space

Ans: _____

20. Write down all the common factors of 12 and 20.

Ans: _____

Total marks for questions 16 to 20

Questions 21 to 30 carry 2 marks each. Show your working clearly and write your answers in the spaces provided. For questions which require units, give your answers in the units stated. All diagrams are not drawn to scale. (20 marks)

Do not write in this space.

21. At a fruit stall, there were 320 fruits altogether. $\frac{1}{4}$ of them were apples, $\frac{5}{8}$ of them were oranges and the rest were mangoes. The fruit stall sold $\frac{3}{4}$ of the mangoes. How many mangoes did the fruit stall sell?

Ans: _____

22. The table shows the charges to post a parcel.

Postage Rates	
Mass Step	Rate
First 500 g	\$2
Every additional 1 kg	\$1.50

Mr Yap posted a parcel that weighed 4.8 kg. How much did Mr Yap pay to post the parcel?

Ans: \$ _____

23. In the figure below, ABCD is a rectangle with AB = 12 cm and BC = 5 cm. Point E lies on DC. DE = 4 cm. Find the area of the shaded triangle.

Do not write in this space

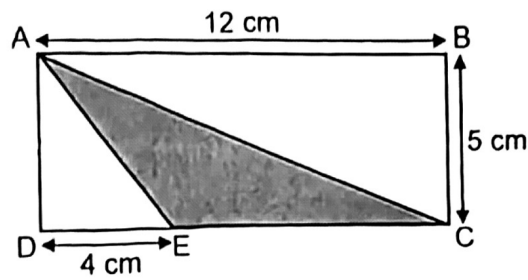

Ans: _____ cm²



24. The average mass of some children is 48 kg. There is an equal number of boys and girls. The average mass of the boys is 50 kg.

Each statement below is either true, false or not possible to tell from the information given. For each statement, put a tick(✓) in the correct column.

Statement	True	False	Not possible to tell
The total mass of the boys is heavier than the total mass of the girls.			
The mass of each girl is 46 kg.			



25. Jack wanted to buy 16 chicken wings but found that he needed another \$5. He bought 7 chicken wings and had \$5.80 left. What was the cost of a chicken wing?

Do not
write in this space.

Ans: \$ _____

26. There are 11 shaded squares in the figure. Shade 2 more squares to form a symmetric figure with AB as the line of symmetry.

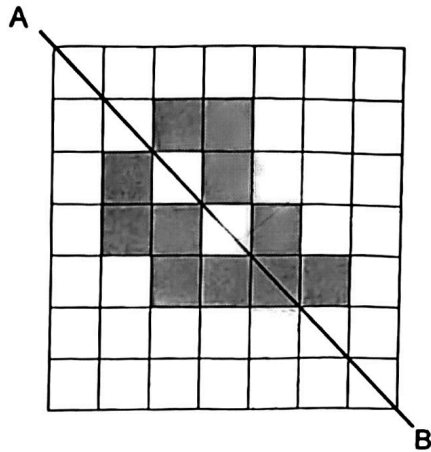

27. 7 unit cubes are glued together to form the solid shown.

Do not write
in this space

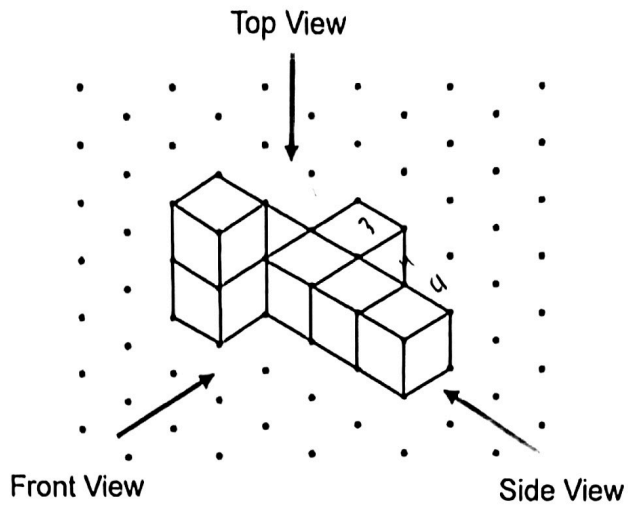

(a) Draw the side view of the solid on the grid.

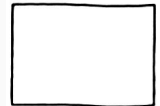
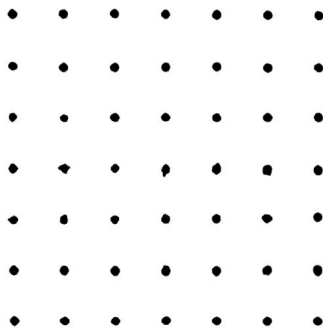

(b) What is the least number of unit cubes to be added to the above solid to form a cube?

Ans: _____



28. The figure below is made up of a square and a rectangle overlapping each other. The ratio of the shaded area to the area of the square is $1 : 5$. The ratio of shaded area to the area of rectangle is $2 : 9$. What is the ratio of the area of square to the area of the rectangle?

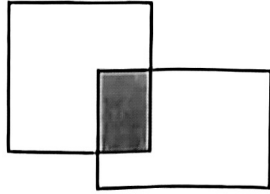

Do not write
in this space

Ans: _____



29. At a party, 87 blue balloons and green balloons line one side of the wall. There are at least 3 blue balloons between any 2 green balloons. What is the greatest possible number of green balloons along the wall?

Ans: _____



30. In the square grid, AB and AD are straight lines. Both lines are part of a trapezium ABCD.

Do not write in this space

(a) AB is parallel to CD. CD is half the length of AB. Draw trapezium ABCD on the grid below.

(b) AD is one side of a rhombus ADEF. Draw ADEF on the grid such that it does not overlap with trapezium ABCD.

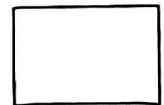
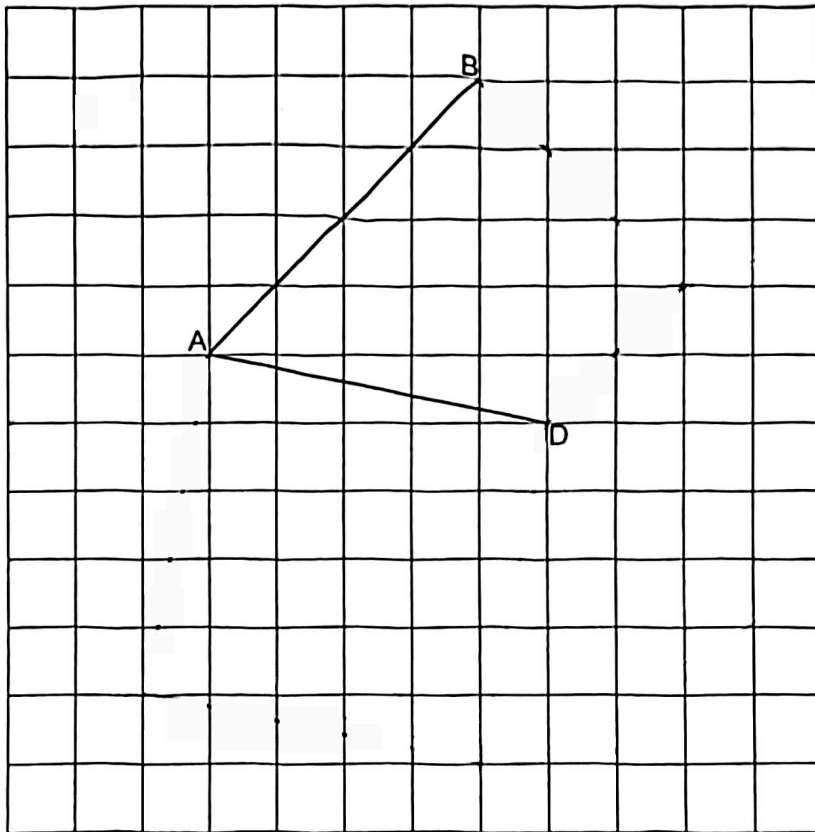

Total marks for questions 21 to 30

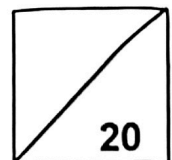

END OF BOOKLET B
END OF PAPER 1

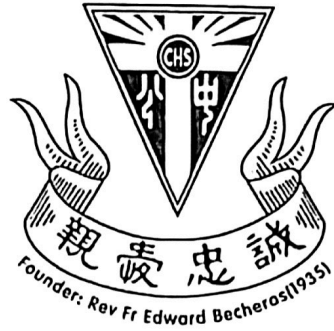

CATHOLIC HIGH SCHOOL
PRELIMINARY EXAMINATION (2025)
PRIMARY SIX
MATHEMATICS
PAPER 2

Name : _____ ()

Class : Primary 6 _____

Date : 20 August 2025

Total time : 1 hour 30 min

17 questions

55 marks

Parent's signature : _____

PAPER 1 BOOKLET A	20
PAPER 1 BOOKLET B	25
PAPER 2	55
Total Marks	100

INSTRUCTIONS TO CANDIDATES

Do not turn over this page until you are told to do so

Follow all instructions carefully.

Answer all questions.

Write your answers in this booklet.

The use of an approved calculator is expected, where appropriate.

This booklet consists of 16 printed pages.

Questions 1 to 5 carry 2 marks each. Show your working clearly in the space below each question and write your answers in the spaces provided. For questions which require units, give your answers in the units stated. All diagrams are not drawn to scale. (10 marks)

Do not write
in this space

1. Richard took 90 minutes to run 5.4 km. What was his average speed in km/h?



Ans: _____ km/h

2. During a sale, a laptop was sold for \$1072 after a 20% discount. How much was the usual price of the laptop?

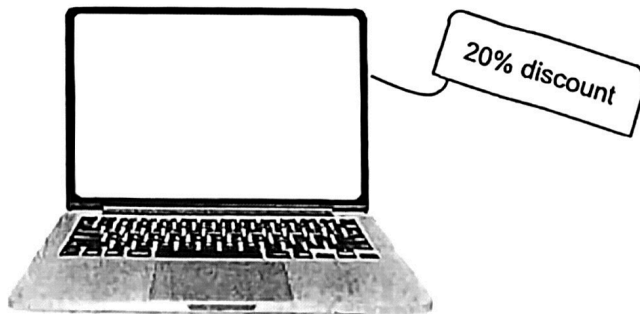

Ans: \$ _____

3. A fruit seller packed 860 apples into bags of 4 for sale. The price of each bag of apples was \$7.80. How much money did the fruit seller collect after selling all the bags of apples?

Do not write in this space

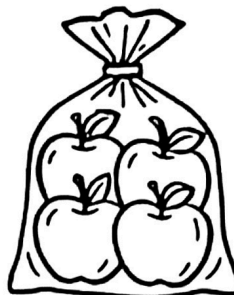

Ans: \$ _____

4. Figure 1 is a triangle with a perimeter of 39 cm. Each side of the triangle has a different design. Figure 2 is made up of 5 such triangles. The perimeter of Figure 2 is 87 cm. What is the length of ST in Figure 1?

Figure 1

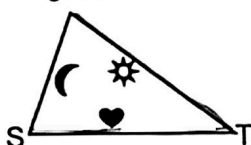
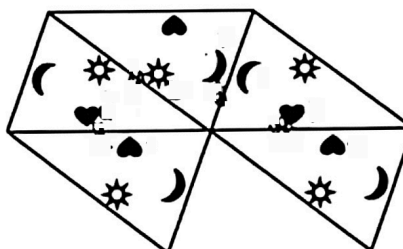

Figure 2



Ans: _____ cm

5. A shop sells only three types of toys. The table shows the number of each type of toy sold in the shop.

Type of Toy	Number of toys sold
Robot	p
Car	$2p + 8$
Doll	45

- (a) Find the total number of toys sold by the shop in terms of p .

Ans: (a) _____

- (b) The shop sold a total of 140 toys. How many toy robots did the shop sell?

Ans: (b) _____

Do not write
in this space

For questions 6 to 17, show your working clearly in the space provided for each question and write your answers in the spaces provided. The number of marks available is shown in brackets [] at the end of each question or part-question. (45 marks)

Do not write in this space

6. The table below shows the number of visitors to a zoo from Thursday to Saturday. The number of visitors to the zoo on Sunday is not shown.

Day	Number of visitors
Thursday	3100
Friday	2690
Saturday	3580
Sunday	?

- (a) The number of visitors to the zoo on Sunday increased by 15% when compared to Saturday. What was the number of visitors to the zoo on Sunday?

Ans: (a) _____ [1]

- (b) What was the percentage decrease in the number of visitors to the zoo on Friday compared to Thursday? Round your answer to 1 decimal place.

Ans: (b) _____ [2]

7.

In the figure, ABC is an isosceles triangle. $AB = BC$. BDEC is a parallelogram. AFE is a straight line. $\angle CBD = 142^\circ$. Find $\angle FED$.

Do not write
in this space

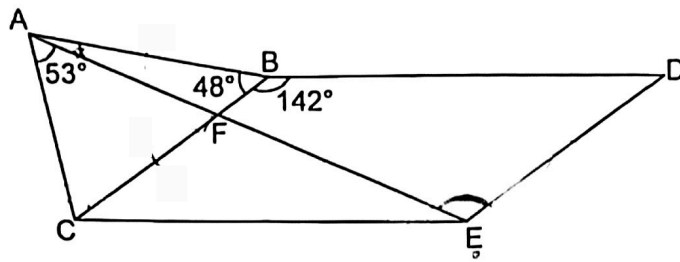

Ans: _____ [3]



8. A baker sold some boxes of tarts and cookies. Each box of tarts cost \$3.10 and each box of cookies cost \$5.50. The baker sold twice as many boxes of tarts as boxes of cookies. He earned a total of \$1439.10. How many boxes of tarts did he sell?

Do not write
in this space

Ans: _____ [3]

9. The first four figures of a pattern are shown below.

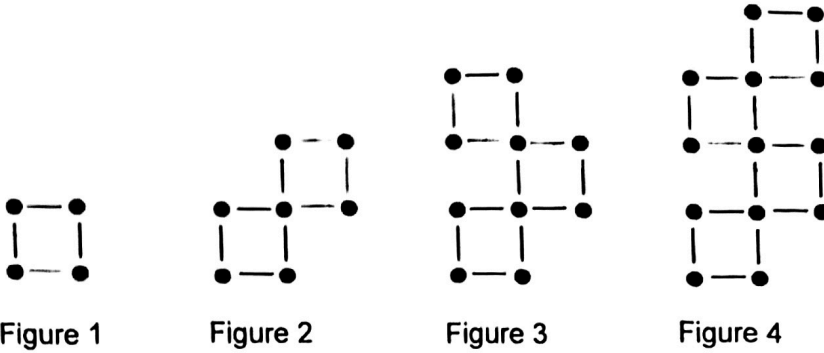

The table below shows the number of dots and lines used for each figure.

Figure Number	1	2	3	4
Number of dots	4	7	10	13
Number of lines	4	8	12	16

(a) A figure in the pattern has 232 lines. What is the Figure number?

Ans: (a) _____ [1]

(b) Find the total number of dots in Figure 70.

Ans: (b) _____ [2]

Do not write
in this space

10. Walter and Cedric started cycling from the same place in opposite directions along a straight path. Walter's speed was 40 m/min faster than Cedric speed. Both of them did not change their speeds throughout. They were 23.38 km apart after they finished cycling. Walter cycled 2.8 km more than Cedric. What was Cedric's speed in m/min?

Do not write
in this space

Ans: _____ [3]

11. The figure shows two stacks of identical paper cups. There are 4 paper cups in the shorter stack and 6 paper cups in the taller stack.

The height of the shorter stack is 21 cm and the height of the taller stack is 25 cm.

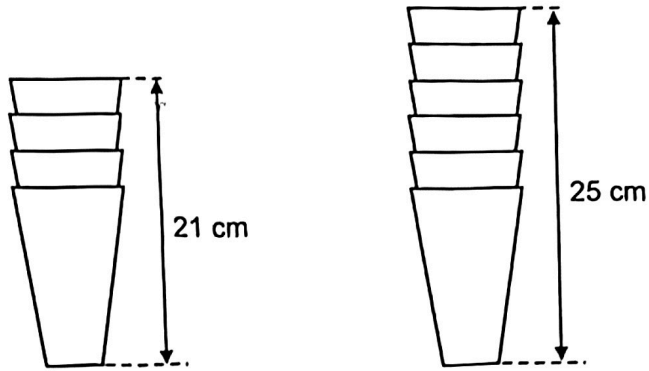

- (a) Find the height of a paper cup.

Ans: (a) _____ [2]

- (b) Mrs Ong wants to pack the paper cups as a single stack into a box of length 50 cm. What is the most number of paper cups she can pack into the box?

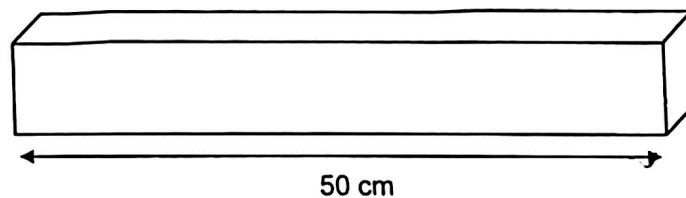

Ans: (b) _____ [2]

12. At first, $\frac{1}{11}$ of a tank was filled with water. A tap was turned on at 10 00 for more water to flow into the tank. It was turned off at 10 20. The graph shows the volume of water in the tank over the 20 minutes.

Do not write
in this space

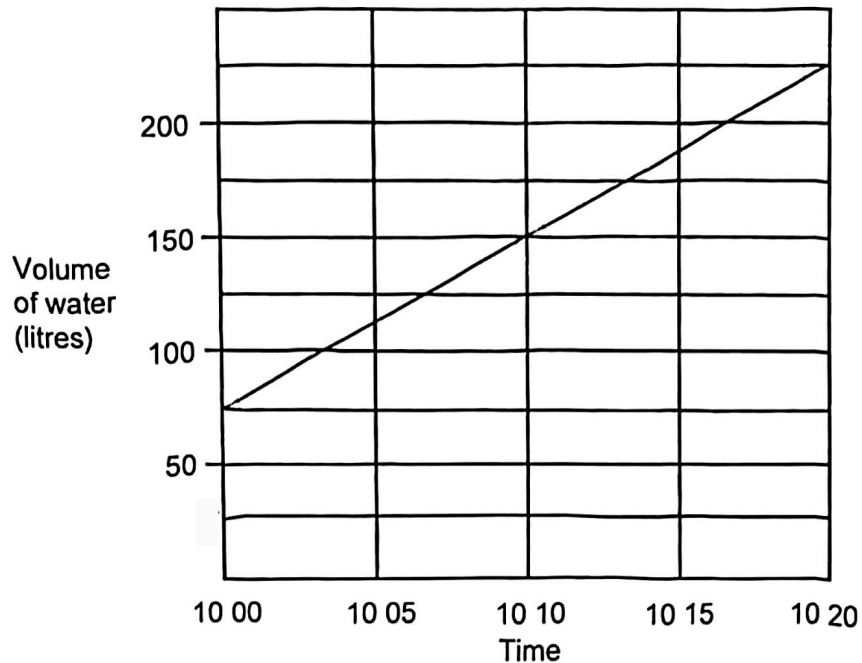

- (a) How many litres of water flowed from the tap in 1 minute?

Ans: (a) _____ [1]

- (b) At 10 30, the tap was turned on again to fill the tank to the brim at the same rate as before. At what time will the tank be filled to the brim with water?

Ans: (b) _____ [3]

13.

Susan designed a logo as shown. The logo is made up of 3 identical small quarter circles, 3 identical big quarter circles and 2 different squares. O is the centre of the small and big quarter circles. The radius of the small quarter circle is 10 cm. Take $\pi = 3.14$

Do not write in this space

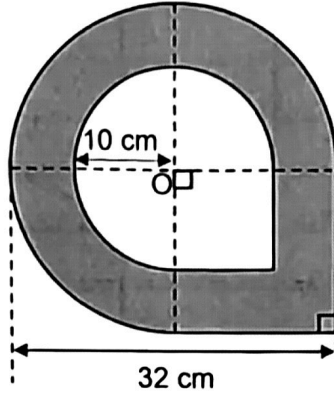

(a) What is the radius of a big quarter circle?

Ans: (a) _____ [1]

(b) What is the total area of the logo that is shaded?

Ans: (b) _____ [3]

14.

A and B are two rectangular containers. The base area of container A is twice the base area of container B. Container A was filled with water to a height of 10 cm and container B was empty.

Do not write in this space

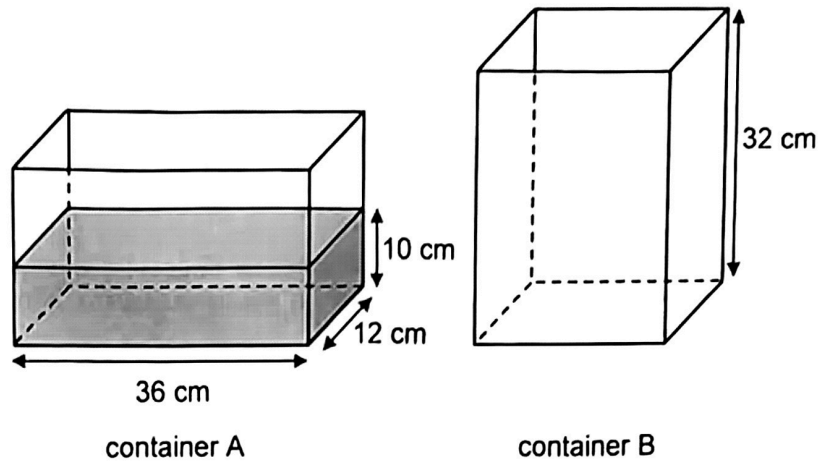



(a) What was the volume of the water in container A?

Ans: (a) _____ [1]

(b) All the water from container A was poured into container B without spilling. How much more water was needed to fill container B to the brim?

Ans: (b) _____ [3]

15. Mr Lee and Mrs Sim bought muffins at the price as shown below.

chocolate muffins	vanilla muffins
	
3 for \$5	4 for \$6

- (a) Mr Lee bought an equal number of chocolate muffins and vanilla muffins. He spent \$24 more on the chocolate muffins. How many muffins did he buy altogether?

Ans: (a) _____ [3]

- (b) Mrs Sim spent an equal amount of money on the chocolate muffins and vanilla muffins. What fraction of the muffins she bought were chocolate? Leave your answer in the simplest form.

Ans: (b) _____ [2]

Do not
in this space

16. Chloe spent $\frac{5}{8}$ of her money on 3 identical books and 7 identical files. The cost of each book was 3 times the cost of each file. She bought some more files with $\frac{5}{6}$ of her remaining money and had \$4 left. How much did Chloe spend on the files altogether?

Do not write
in this space

Ans: _____ [5]



17. Three boys Lionel, Michael and Nate had the same number of coins. Lionel and Michael each had a mix of fifty-cent and ten-cent coins. Lionel had 10 ten-cent coins, while Michael had 15 ten-cent coins. Nate had only fifty-cent coins.

(a) How much more money did Lionel have than Michael?

Ans: (a) _____ [2]

(b) Michael used all his fifty-cent coins to buy some food. He then had \$8 less in coins than Nate. How many fifty-cent coins did Nate have?

Ans: (b) _____ [2]

END OF PAPER 2

SCHOOL : CATHOLIC HIGH SCHOOL

LEVEL : PRIMARY 6

SUBJECT : MATH

TERM : 2025 PRELIM EXAM

BOOKLET A

Q1	Q2	Q3	Q4	Q5	Q6	Q7	Q8	Q9	Q10
3	4	1	2	3	1	4	2	1	3
Q11	Q12	Q13	Q14	Q15					
2	1	3	4	2					

BOOKLET B

Q16	Three million, six thousand and forty in numerals → 3,006,040 ANS : 3,006,040
Q17	39,470 to nearest thousand → 39,000 ANS : 39,000
Q18	$\frac{3}{8} \div 18 = \frac{3}{8} \times \frac{1}{18} = \frac{1}{8} \times \frac{1}{6} = \frac{1}{48}$. ANS : $\frac{1}{48}$
Q19	$3w - 9 + \frac{w}{4} = 3(8) - 9 + \frac{8}{4} = 24 - 9 + 2 = 17$. ANS : 17
Q20	$12 = 1 \times 12 = 2 \times 6 = 3 \times 4$, $20 = 1 \times 20 = 2 \times 10 = 4 \times 5$, Common factors = 1, 2 and 4 ANS : 1, 2, 4
Q21	$1 - \frac{1}{4} - \frac{5}{8} = \frac{8-2-5}{8} = \frac{1}{8}$, $320 \times \frac{1}{8} = 40$ mangoes at first, $40 \times \frac{3}{4} = 30$. ANS : 30
Q22	$4.8 \text{ kg} = 0.5 \text{ kg} + 4 \text{ kg} + 0.3 \text{ kg} = 500 \text{ g} + 4 \text{ kg} + 0.3 \text{ kg}$, Fee = \$2 + 4 × \$1.50 + \$1.50 = \$9.50 ANS : \$9.50
Q23	EC = 12 - 4 = 8 cm. Area of shaded triangle = $0.5 \times 8 \times 5 = 20 \text{ cm}^2$. ANS : 20 cm ²

Q24 Assume number of boys = number of girls = n.
 Total mass of children = $48 \times 2n = 96n$ kg.
 Total mass of boys = $50 \times n = 50n$ kg.
 \therefore Total mass of girls = $96n - 50n = 46n$ kg.
 ① The total mass of the boys (50n kg) is heavier than the total mass of the girls (46n kg) since $50n > 46n$.
 ② Average mass of the girls = $46n \div n = 46$ kg.
 But the mass of each girl is not possible to tell.

Statement	True	False	Not possible to tell
The total mass of the boys is heavier than the total mass of the girls	✓		
The total height of Ali and his parents is $(32 + 4u)$ cm.			✓

Q25 $16 - 7 = 9$ chicken wings \rightarrow $\$5.00 + \$5.80 = \$10.80$
 Cost of a chicken wing = $\$10.80 \div 9 = \1.20 .
 ANS : \$1.20

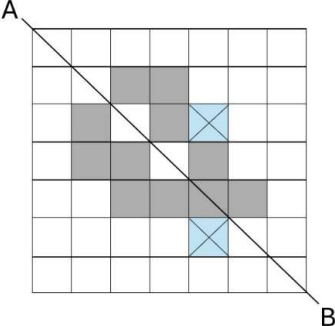
Q26 

ANS : See figure

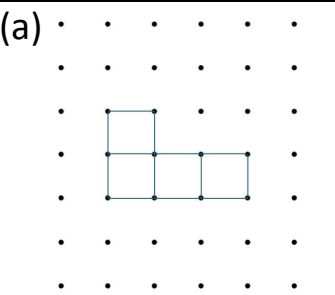
Q27 (a) 

ANS : (a) See figure

(b) $4 \times 4 \times 4 - 7 = 64 - 7 = 57$. (b) 57 unit cubes

Q28 Area of square : shaded area : area of rectangle
 $= 2(5) : 2(1) : 9 = 10 : 2 : 9$.
 \therefore Area of square : area of triangle = $10 : 9$.
 ANS : 10 : 9

Q29	$1 + 3 = 4$, $87 \div 4 = 21R3$, Greatest number of green balloons = $21 + 1 = 22$. ANS : 22
Q30	<p>ANS : (a), (b) see figure</p>

PAPER 2

Q1	$90 \text{ min} = 1.5 \text{ hours}$, average speed = $5.4 \div 1.5 = 3.6 \text{ km/h}$. ANS : 3.6 km/h
Q2	Usual price = $\$1072 \div 80\% = \$1,340$. ANS : \$1,340
Q3	$860 \div 4 = 215$, $215 \times \$7.80 = \$1,677$. ANS : \$1,677
Q4	<div style="display: flex; justify-content: space-around;"> <div style="text-align: center;"> <p>Figure 1</p> </div> <div style="text-align: center;"> <p>Figure 2</p> </div> </div> <p> $a + b + c = 39$ -- ① $3a + 3b + c = 87$ -- ② $3 \times \text{①} - \text{②}$, $3(a + b + c) - (3a + 3b + c) = 3 \times 39 - 87$, $3a + 3b + 3c - 3a - 3b - c = 117 - 87$, $2c = 30$, $\rightarrow c = ST = 30 \div 2 = 15 \text{ cm}$. ANS : 15 cm </p>

Q5	<p>(a) $p + (2p + 8) + 45 = 3p + 53$.</p> <p>(b) $3p + 53 = 140$, $p = (140 - 53) \div 3 = 87 \div 3 = 29$.</p> <p style="text-align: right;">ANS : (a) $(3p + 53)$ (b) 29</p>
Q6	<p>(a) Sunday: $3580 \times 115\% = 4,117$.</p> <p>(b) Percentage decrease = $\frac{3100 - 2690}{3100} \times 100\% = 13.2\%$</p> <p style="text-align: right;">ANS : (a) 4,117 (b) 13.2%</p>
Q7	<p>$\angle ACB = (180^\circ - 48^\circ) \div 2 = 66^\circ$ (isosceles triangle ABC), $\angle BCE = 180^\circ - 142^\circ = 38^\circ$ (int. \angles, BC // DE), $\angle AEC = 180^\circ - 53^\circ - 66^\circ - 38^\circ = 23^\circ$ (\angle sum of triangle ACE) $\angle FED = 142^\circ - 23^\circ = 119^\circ$ (Opp. \angles of a parallelogram)</p> <p style="text-align: right;">ANS : 119°</p>
	<p>Sales of 2 boxes of tarts and 1 box of cookies $= 2 \times \\$3.10 + 1 \times \\$5.50 = \\$11.70$.</p> <p>Number of boxes of cookies sold = $\\$1439.10 \div \\$11.70 = 123$.</p> <p>Number of boxes of tarts sold = $2 \times 123 = 246$.</p> <p style="text-align: right;">ANS : 246</p>
Q9	<p>(a) $232 \div 4 = 58$. ANS : (a) Figure 58.</p> <p>(b) $4 + (70 - 1) \times 3 = 211$ (b) 211 dots.</p>
Q10	<p>Time spent by Walter and Cedric on cycling $= 2.8 \text{ km} \div 40 \text{ m/min} = 2800 \text{ m} \div 40 \text{ m/min} = 70 \text{ min}$.</p> <p>Combines speed of Walter and Cedric $= 23380 \text{ m} \div 70 \text{ min} = 334 \text{ m/min}$.</p> <p>$\therefore$ Cedric's speed = $(334 - 40) \div 2 = 147 \text{ m/min}$</p> <p style="text-align: right;">ANS : 147 m/min</p>
Q11	<p>(a) $(25 - 21) \div 2 = 4 \div 2 = 2 \text{ cm}$, Height of a cup = $21 - 3 \times 2 = 15 \text{ cm}$.</p> <p>(b) $50 - 15 = 35$, $35 \div 2 = 17 \text{ R } (1\text{cm})$ Most number of paper cap = $17 + 1 = 18$.</p> <p style="text-align: right;">ANS : (a) 15 cm (b) 18</p>

Q16

$\frac{5}{8}$ of money \rightarrow 3 books and 7 files.

1 book \Leftrightarrow 3 files.

$\therefore \frac{5}{8}$ of money $\rightarrow 3 \times 3 + 7 = 9 + 7 = 16$ files.

Remaining fraction of money $= 1 - \frac{5}{8} = \frac{3}{8}$.

$\frac{5}{6} \times \frac{3}{8} = \frac{5}{16} = \frac{1}{2} \times \frac{5}{8}$ of money $\rightarrow \frac{1}{2} \times 16 = 8$ files.

Fraction of money left $= \frac{1}{6} \times \frac{3}{8} = \frac{1}{16} \rightarrow \4 .

Amount of money Chloe had at first $16 \times \$4 = \64 .

$16 + 8 = 24$ files $\Leftrightarrow (1 - \frac{1}{16}) \times \$64 = \frac{15}{16} \times \$64 = \$60$.

Cost of 1 file $= \$60 \div 24 = \2.50 .

\therefore Amount of money spent on $7 + 8 = 15$ files
 $= 15 \times \$2.50 = \37.50

ANS: \$37.50

Q17

(a)

Name	Same total number of 50¢ and 10¢ coins	
Lionel	? 50¢ coins	10 10¢ coins
Michael	? 50¢ coins	15 10¢ coins
Nate	? 50¢ coins	

From the table, Lionel has $15 - 10 = 5$ more 50¢ coins but 5 less 10¢ coins than Michael.

\therefore Lionel has $5 \times (50¢ - 10¢) = 5 \times 40¢ = 200¢ = \2 .

(b) Michael has left with $15 \times 10¢ = 150¢$.

Amount of money Nate had $= \$8 + 150¢ = 800¢ + 150¢$
 $= 950¢$.

Nate had $950¢ \div 50¢ = 19$ (50¢ coins).

ANS: (a) \$2

(b) 19 50¢ coins