

PSLE Index Number:

--	--	--	--	--	--	--	--	--	--

**MARIS STELLA HIGH SCHOOL (PRIMARY)****PRELIMINARY EXAMINATION****20 August 2024****SCIENCE****(BOOKLET A)**

Total Time for Booklets A and B: 1 hour 45 minutes

INSTRUCTIONS TO CANDIDATES

1. Do not turn over this page until you are told to do so.
 2. Follow all instructions carefully.
 3. Answer all questions.
 4. Shade your answers on the Optical Answer Sheet (OAS) provided.
-

Name: _____ ()

Class: 6 _____

For each question from 1 to 20, four options are given. One of them is the correct answer. Make your choice (1, 2, 3 or 4). Shade the correct oval (1, 2, 3 or 4) on the Optical Answer Sheet (OAS).
(20 x 2 marks)

1 Which of the following characteristic(s) is/are found in insects, but not in other animals?

- A They lay eggs.
- B They have wings.
- C They have 3 body parts.
- D They have 3 pairs of legs

- (1) B only
- (2) C and D only
- (3) B, C and D only
- (4) A, B, C and D

2 Which of the following characteristics is most likely correct of animal-pollinated and wind-pollinated flowers?

	Animal-pollinated flowers	Wind-pollinated flowers
(1)	feathery stigma	sticky stigma
(2)	presence of nectar	presence of nectar
(3)	anthers hang out of flowers	anthers hidden inside the flowers
(4)	brightly coloured petals	dull-coloured petals

3 Which of the following is correct?

- (1) Burning of fuels causes the thinning of ozone layer.
- (2) Reforestation helps to reduce soil erosion and flooding.
- (3) Cutting down of trees increases haze and global warming.
- (4) Disposal of wastes in water increase water pollution and haze.

- 4 Fatimah examined cells taken from organisms A, B, C and D under a microscope and recorded her observations in the chart below.

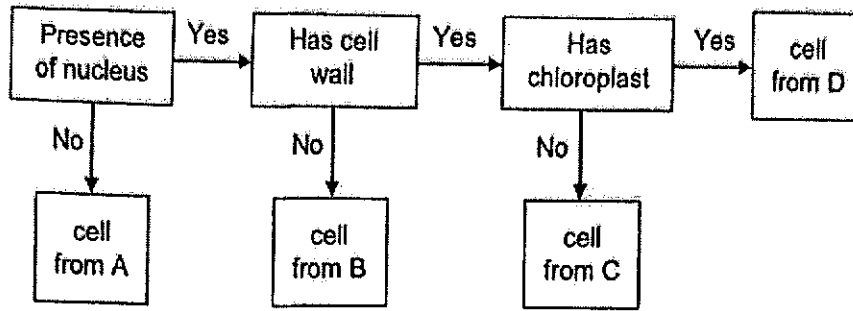

She then examined cell X and classified it as shown below.

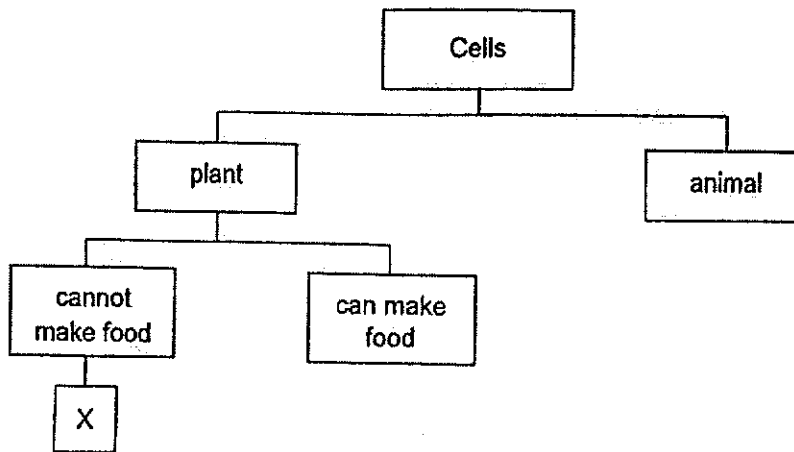

From which organism, A, B, C or D, is cell X most likely taken from?

- (1) A
- (2) B
- (3) C
- (4) D

5 In which diagram is "germination" and "fertilisation" correctly placed?

(1)

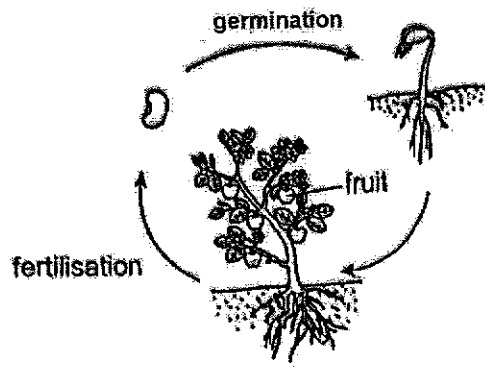

(2)

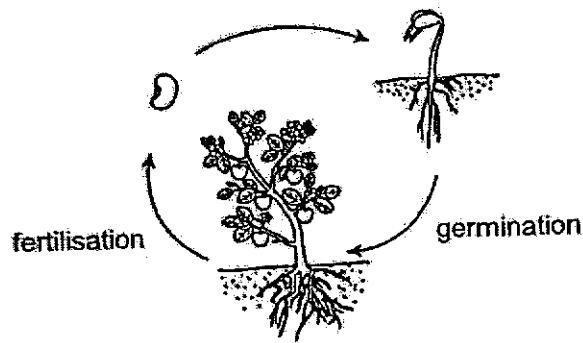

(3)

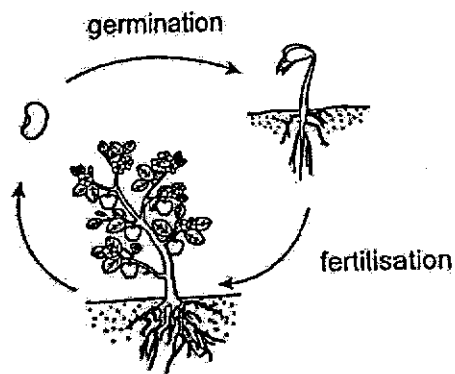

(4)

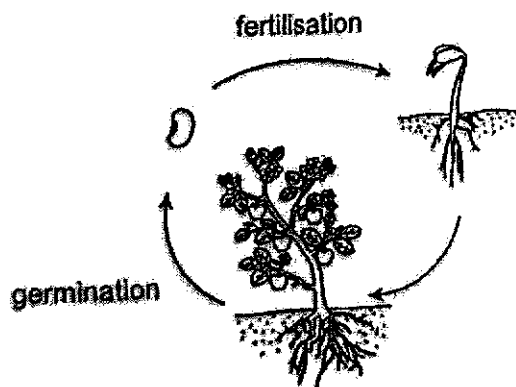

6 The diagram shows how food and water are transported through different parts of a plant.

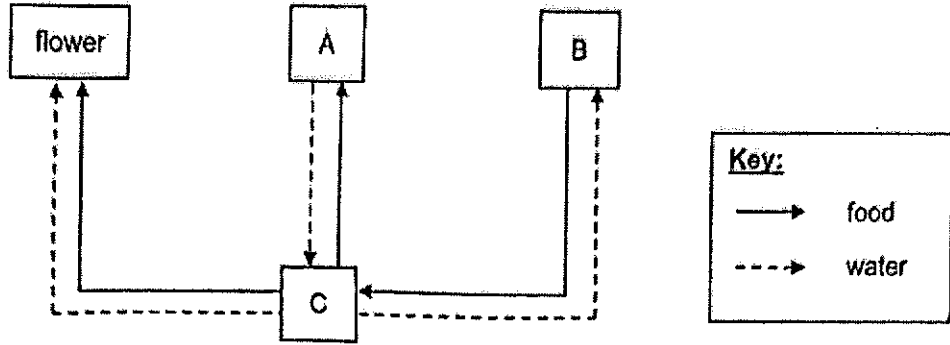

Which of the following correctly shows the parts of the plant that are represented by A, B and C?

	A	B	C
(1)	leaf	root	stem
(2)	root	leaf	stem
(3)	stem	root	leaf
(4)	root	stem	leaf

7 Plant A climbs around another plant B to get more sunlight. B provides support for A.

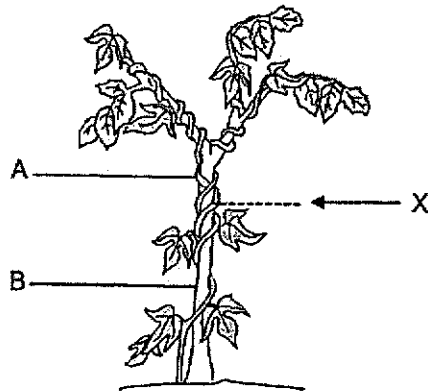

The stem of A was cut at X. The part of A above X died after some time.

Which of the following best explains why?

- (1) There was a lack of chloroplasts.
- (2) The plant did not receive enough light.
- (3) The part above X did not receive water.
- (4) The part above X had no support from B.

- 8 Donovan watered a plant and wrapped it with a black plastic bag as show below. He the placed it in the sun for 3 hours.

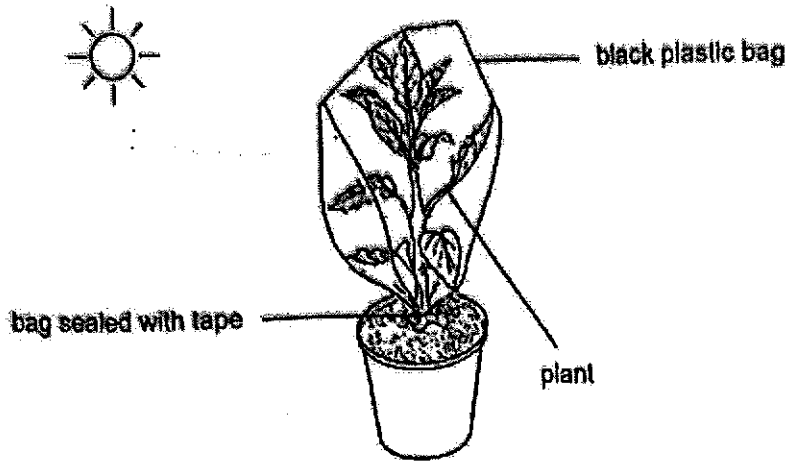

Which one of the following graphs correctly shows the changes in the level of oxygen and carbon dioxide in the black plastic bag during the 3-hour period?

(1)

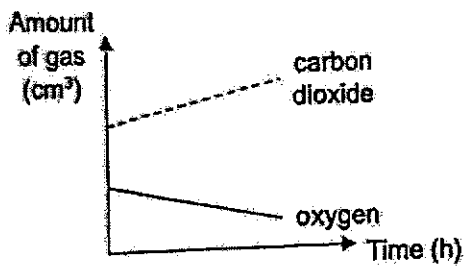

(2)

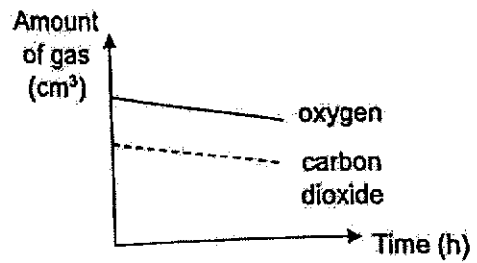

(3)

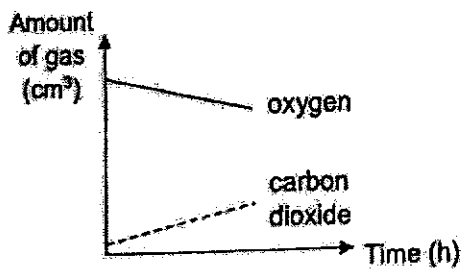

(4)

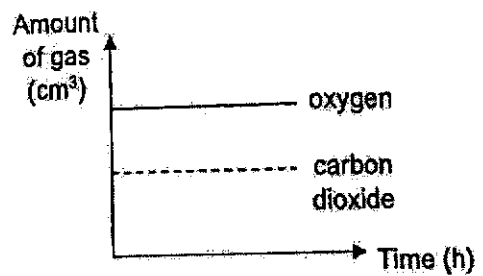

9 The diagrams below show the food webs in two different habitats, X and Y.

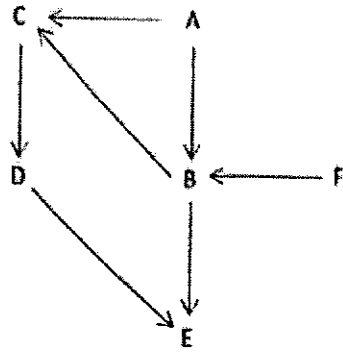

habitat X

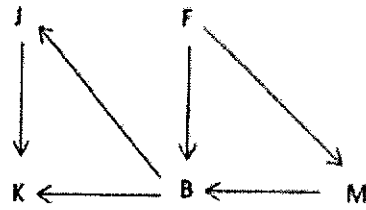

habitat Y

Which organism in habitat X will most likely not survive in habitat Y?

- (1) A
- (2) C
- (3) D
- (4) E

10 Study the food web in a habitat with organisms A, B, C and D.

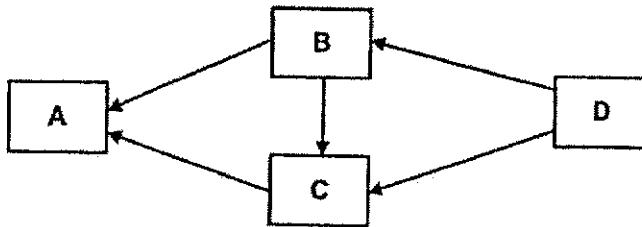

A large number of organisms X were accidentally introduced into the habitat. X only fed on one type of organism in this habitat. After some time, all the organisms decreased in number.

Which organism did X feed on?

- (1) A
- (2) B
- (3) C
- (4) D

- 11 More aquatic plants are found near the surface rather than at the bottom of a deep pond. What is the main reason for this ?

- (1) They can obtain light for photosynthesis.
- (2) They can get more nutrients to grow better.
- (3) They can take in oxygen from the air above water.
- (4) They can provide shade and shelter for animals in the pond.

- 12 The table shows the functions of the adaptations of three organisms, X, Y and Z, which live in an aquatic environment.

Organism	Function of adaptations
X	to stay afloat on water
Y	to escape from predators
Z	to allow exchange of gases

Which of the following adaptations correctly match to organisms X, Y and Z?

	X	Y	Z
(1)	webbed feet	strong tail	scales
(2)	gills	body coloured and shaped like a leaf	moist skin
(3)	swollen leaf stalks with air spaces	strong tail	scales
(4)	waxy leaves	body coloured and shaped like a leaf	lungs

- 13 The air we breathe in mainly consists of gases J, K and L. The key below shows the three gases.

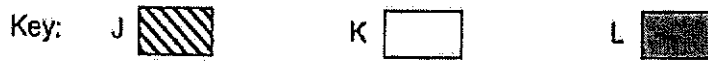

The following bar indicates the composition of the three gases in the air that we breathe in.



Which of the following statements is correct?

- (1) Humans need J to stay alive.
 - (2) Plants need to take in K during photosynthesis.
 - (3) The air we breathe out has less J than the air we breathe in.
 - (4) The air we breathe out has more L than the air we breathe in.
- 14 The diagram below shows the reproductive parts of a female human and a flowering plant.

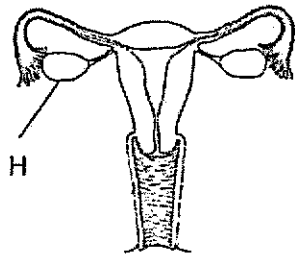

Human reproductive system

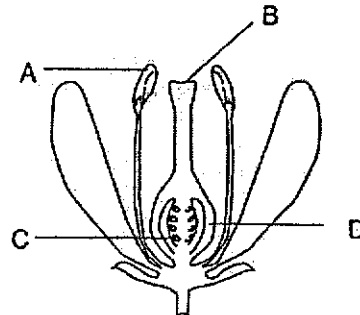

Flowering plant reproductive system

Which part of the flower has a similar function as part H?

- (1) A
- (2) B
- (3) C
- (4) D

- 15 The diagram below shows the direction of blood flow in the human body.

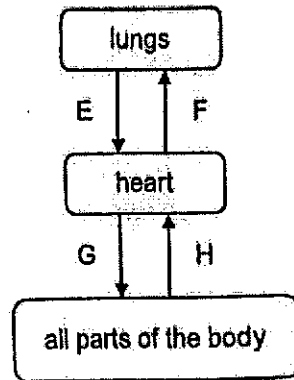

Which of the following correctly describes the blood in E, F, G and H?

	Blood poor in oxygen	Blood poor in carbon dioxide
(1)	E and F	G and H
(2)	E and G	F and H
(3)	G and H	E and F
(4)	F and H	E and G

16 Study the flow chart below.

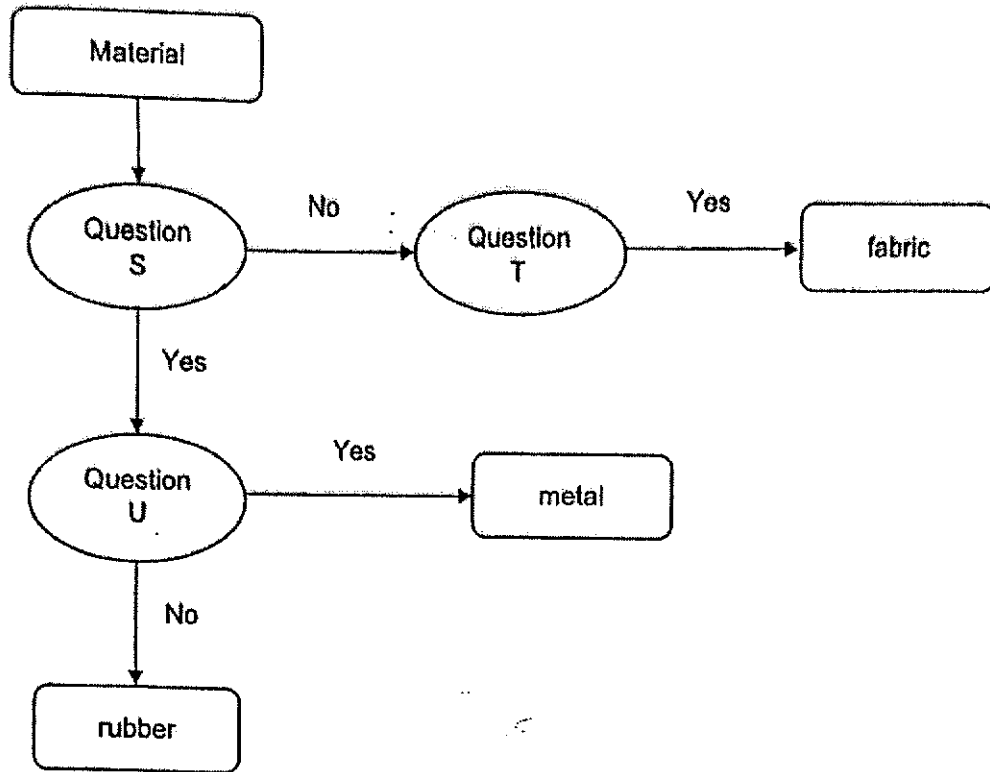

Which one of the following is definitely correct?

	Question S	Question T	Question U
(1)	Is it flexible?	Is it waterproof?	Is it a non-conductor of electricity?
(2)	Is it waterproof?	Is it flexible?	Is it a good conductor of heat?
(3)	Is it a conductor of electricity?	Is it waterproof?	Is it a poor conductor of heat?
(4)	Is it a good conductor of heat?	Is it flexible?	Is it a conductor of electricity?

17 What will possibly happen to the water cycle when the temperature of the environment decreases?

- (1) Condensation of water vapour increases resulting in less rain.
- (2) Evaporation of water decreases resulting in less cloud formed.
- (3) Evaporation of water increases resulting in more cloud formed.
- (4) Condensation of water vapour decreases resulting in more rain.

18 Study the set-up. The capacity of the air-tight flask is 500 cm^3 . It contains 200 cm^3 of water.

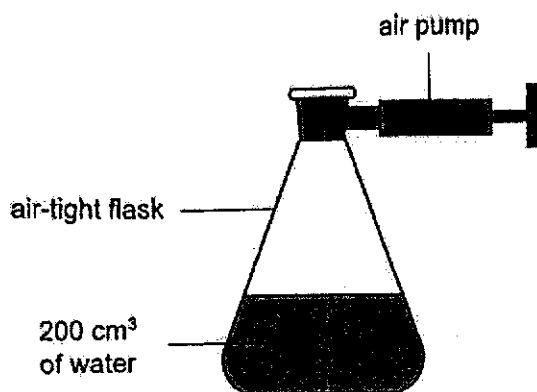

Which of the following statements is true after 100 cm^3 of air is added into the flask using the air pump?

- (1) The mass of air in the flask decreased.
- (2) The volume of air in the flask decreased.
- (3) The mass of air in the flask remained the same.
- (4) The volume of air in the flask remained the same.

- 19 James placed a wooden spoon and a metal fork overnight in the refrigerator. When he removed the spoon and fork from the refrigerator at the same time, his hands felt that the fork was colder than the spoon.

Which of the following explains why his hands felt that the fork was colder than the spoon?

- (1) The fork conducted heat better than the spoon.
 - (2) The fork transferred more coldness to his hands.
 - (3) The fork had a lower temperature than the spoon.
 - (4) The fork had a greater surface area than the spoon.
- 20 The graph below shows the temperature change of substances P and Q as melting and boiling took place.

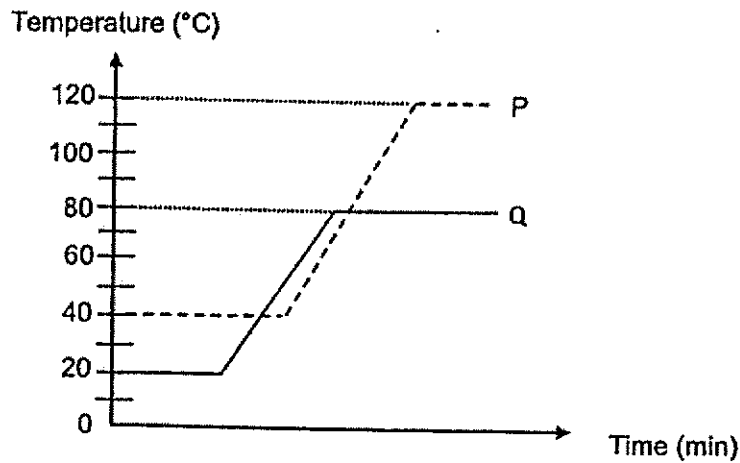

Based on the graph, at which temperatures are substances P and Q completely in solid state?

	P	Q
(1)	20 $^{\circ}\text{C}$	10 $^{\circ}\text{C}$
(2)	40 $^{\circ}\text{C}$	20 $^{\circ}\text{C}$
(3)	80 $^{\circ}\text{C}$	60 $^{\circ}\text{C}$
(4)	120 $^{\circ}\text{C}$	80 $^{\circ}\text{C}$

- 21 Ricky heated up a pot of water until it boiled.

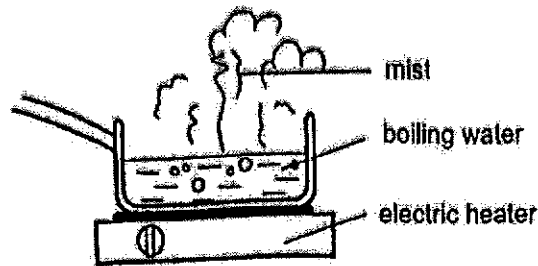

He made the following statements about the pot of water.

- A The mist is in the gaseous state.
- B Boiling occurs only at the surface of the water.
- C As the water boils, water changes from liquid to gaseous state.

Which of the above statements made by Ricky is/are correct?

- (1) C only
- (2) A and B only
- (3) A and C only
- (4) A, B and C

- 22 The diagram below shows a solar-powered fan.

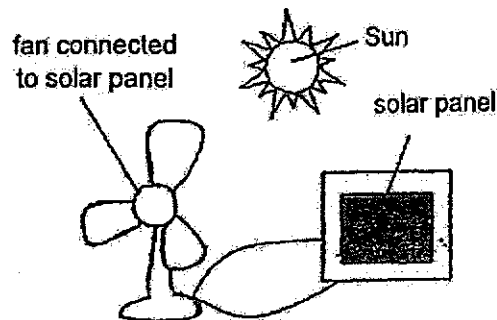

Which of the following correctly shows the energy conversion when the solar-powered fan is used?

- (1) electrical energy \rightarrow kinetic energy
- (2) light energy \rightarrow electrical energy \rightarrow kinetic energy
- (3) light energy \rightarrow chemical potential energy \rightarrow sound energy
- (4) chemical potential energy \rightarrow electrical energy \rightarrow kinetic and sound energy

- 23 Xinru brought two bar magnets close to each other and observed the movements of the magnets as indicated by the arrows shown in the diagram below.

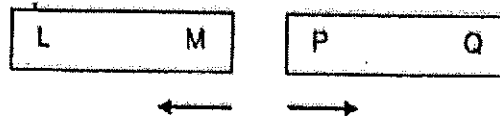

She then placed a compass near end P and observed the direction of the compass needle as shown below.

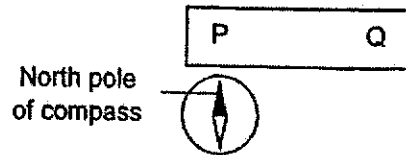

Which of the following correctly represents the poles at L and Q of the bar magnets?

	Pole at L	Pole at Q
(1)	North	South
(2)	North	North
(3)	South	North
(4)	South	South

24 Ben went for an indoor skydiving activity. Air was being blown in continuously below the flying chamber to keep him afloat in position C.

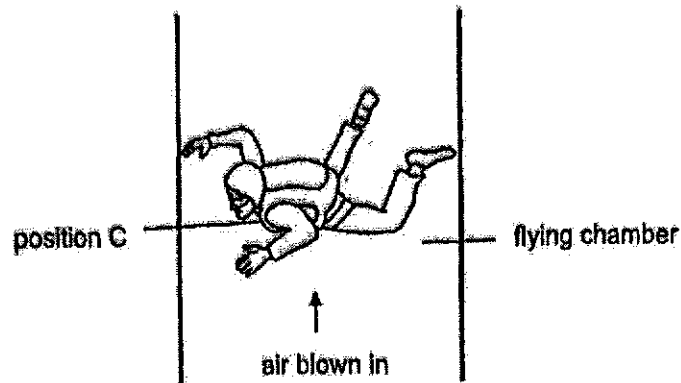

Which of the following correctly explains why Ben was able to stay afloat at position C in the flying chamber?

- (1) There is no gravitational force acting on Ben in the flying chamber.
- (2) Gravitational potential energy of Ben is converted to kinetic energy.
- (3) The upward force exerted by the moving air blown at Ben is greater than his weight.
- (4) The gravitational force acting on Ben was equal to the upward force exerted by the moving air blown at him.

25 The graph below shows the energy conversion of an action.

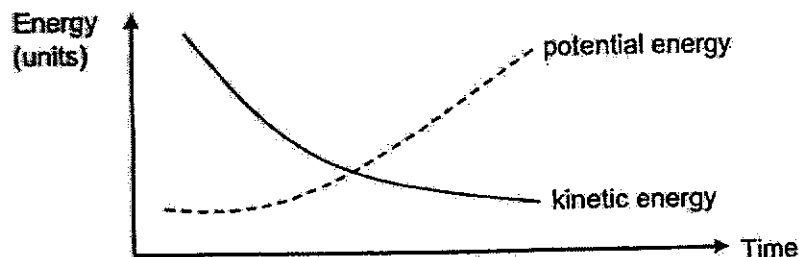

Which of the following actions would show the same energy conversion as above?

- (1) throwing a ball upward
- (2) an apple falling off a tree
- (3) rolling a ball across a flat ground
- (4) a battery-operated fan that is turned on

26 Identical batteries and bulbs are used in the three circuits as shown.

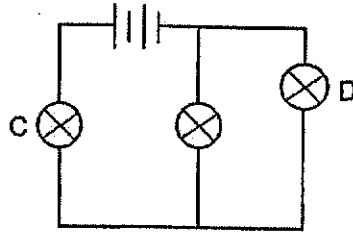
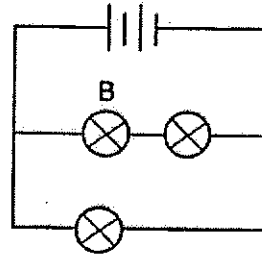
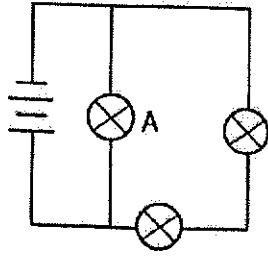

Which statement about the brightness of the bulbs is correct?

- (1) Bulb A is as bright as bulb C.
- (2) Bulb B is as bright as bulb D.
- (3) Bulb C is brighter than bulb B.
- (4) Bulb B is brighter than bulb A.

- 27 The following set-up uses a light sensor to count the number of identical cans on a moving belt.

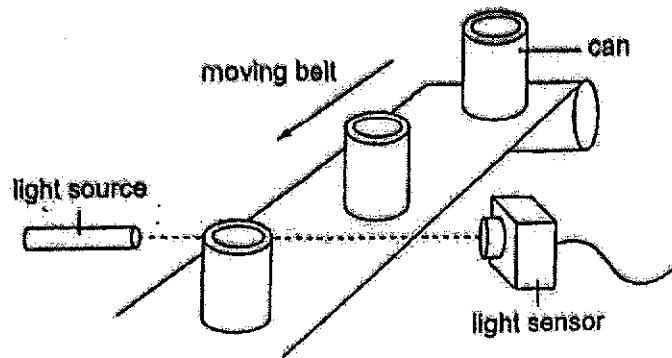

The graph below shows the results recorded when the cans moved past the light sensor within a time frame of 50 seconds.

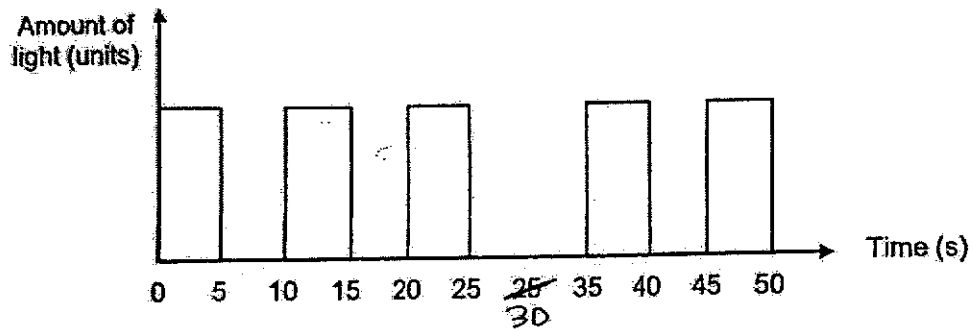

Based on the given graph, which of the following can be concluded?

- (1) Five cans moved past the light sensor.
- (2) Four cans moved past the light sensor.
- (3) The belt was moving at a constant speed.
- (4) The cans were placed at different distances apart.

28 A wooden block moved down a ramp after it was released as shown below.

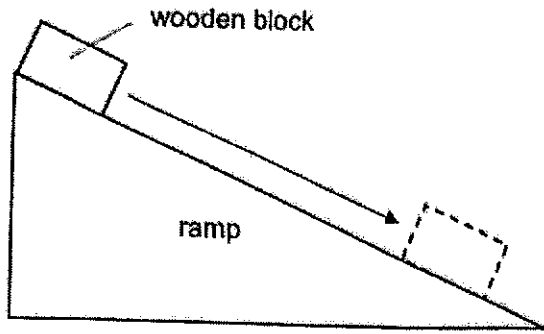

Which of the following correctly shows the amount of gravitational force, and the direction of gravitational and frictional forces acting on the block as it moved down the ramp?

	Amount of gravitational force	Direction of gravitational force acting on the block	Direction of frictional force acting on the block
(1)	decreases		
(2)	increases		
(3)	remains the same		
(4)	remains the same		

PSLE Index Number:

--	--	--	--	--	--	--	--



MARIS STELLA HIGH SCHOOL (PRIMARY)

PRELIMINARY EXAMINATION

20 August 2024

SCIENCE

(BOOKLET B)

Total Time for Booklets A and B: 1 hour 45 minutes

INSTRUCTIONS TO CANDIDATES

1. Do not turn over this page until you are told to do so.
2. Follow all instructions carefully.
3. Answer all questions.
4. Use a dark blue or black ballpoint pen to write your answers in the space provided for each question.
5. Do not use correction fluid/tape or highlighters.

Booklet A: _____ / 56
Booklet B: _____ / 44
Grand Total: _____ / 100

Parent's Signature: _____

Name: _____ ()
Class: 6 _____

For questions 29 to 40, write your answers in this booklet. The number of marks available is shown in brackets [] at the end of each question or part question. (44 marks)

- 29 (a) Name three parts found in the human circulatory system. [1]

- (b) Describe how the digestive system works together with the circulatory system in our body. [2]

- 30 Some farmers clear forests by cutting down the trees.

- (a) Explain how the loss of trees can lead to global warming. [1]

- (b) After a forest was cleared, it was observed that the submerged plants in a nearby river died in large numbers after a long period of heavy rainfall.

Explain how the loss of trees led to the death of the submerged plants in the river. [2]

31 The diagram below shows the life cycle of a mosquito.

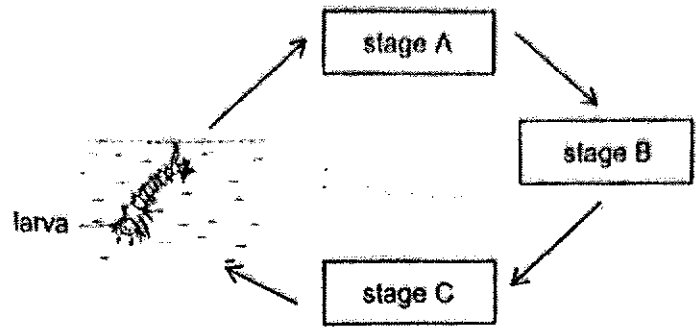

(a) What are stages A and C? [1]

Stage A: _____

Stage C: _____

Oil is sprayed on stagnant water as shown. ...

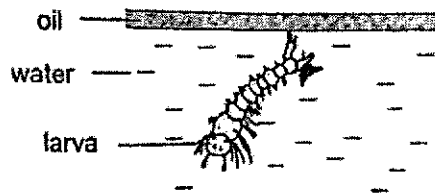

(b) Explain how this prevents the mosquito larva from growing into adults. [1]

(c) The mosquito can carry diseases that make people sick. Give a reason why only stage B can spread diseases to people. [1]

32 The food web below shows the food relationships between organisms in a community.

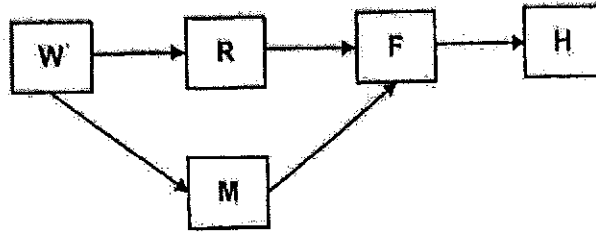

- (a) A large number of F died due to a disease outbreak. Explain how this affects the population of W. [2]

The diagram shows how a fruit is formed from a flower of W.

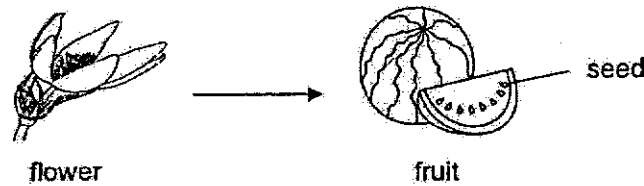

- (b) State the parts of the flower that the fruit and seed are developed from. [1]

Fruit: _____

Seed: _____

R eats the juicy flesh and indigestible seeds of the fruits of W.

- (c) Describe how the seeds of W can be dispersed by R over a wide area. [1]

- (d) Besides reducing overcrowding, state another benefit for W when R dispersed its seeds. [1]

33 Plant A shed its leaves just before winter season. During winter, temperatures go below 0°C.



plant A in summer



plant A in winter

(a) Substances move in and out of tiny openings found on the underside of leaves. By shedding its leaves, plant A is reducing the movement of substance X through these tiny openings to increase its chances of survival.

Name substance X. [1]

(b) Explain how the fallen leaves can be beneficial for plant A. [1]

Yuming placed two set-ups, P and Q, as shown below, in the same location. Other than the number of leaves, the two pots of plant in set-ups P and Q are identical and are provided with the same conditions to grow.

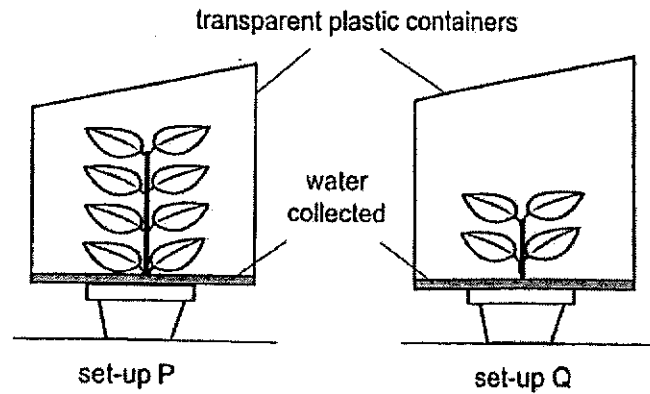

(c) After a day, Yuming observed that water was collected at the base of the plastic containers. More water was collected in set-up P. Explain why. [2]

34 Animal J lives in hot places and feeds on animals.



animal J

- (a) Animal J has a good sense of hearing.
Suggest two ways how this helps animal J survive. [2]



- (b) Animal J loses heat through its ears.
Explain how having big ears could be an advantage for animal J. [2]

- 35 The table below shows the melting point and boiling point of substances D and E.

Substance	Melting point(°C)	Boiling point (°C)
D	42	86
E	7	20

- (a) In a room at 30 °C, where can substances D and E be stored?
Tick (✓) the correct boxes in the table below.

[2]

Substance	Can be stored in	
	 sealed glass container	 cotton fabric bag
D		
E		

- (b) Explain your choice for substance E in (a).

[1]

	3
--	---

(Go on to the next page)

- 36 Eric has three torches that give off three different coloured lights, red, yellow and blue. He wanted to find out which coloured light will best allow him to see objects underwater.

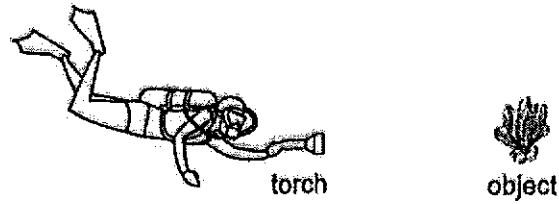

He set up an experiment as shown below and measured the amount of light detected by the light sensor after using the different coloured light torches to shine through water.

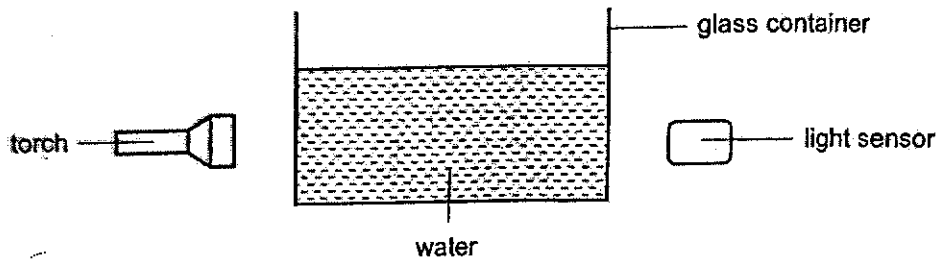

The table below shows Eric's results.

Colour of light	Red	Yellow	Blue
Amount of light detected by the light sensor (unit)	8	15	50

- (a) Based on the results, which coloured light, red, yellow or blue, will allow Eric to see objects most clearly in water? Explain your answer. [2]

	2
--	---

- (b) Eric also wanted to find out if the distance between the torch and an object in water will affect the amount of light that shines on the object.

He prepared set-up 1 as shown below. The length of the glass container is 50 cm:

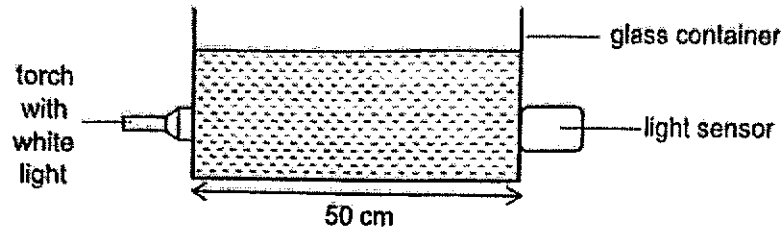

Set-up 1

Eric needs another set-up, set-up 2, for his experiment.

Describe how Eric should prepare set-up 2.

You may use a diagram in your answer. Label all parts of your diagram.

[2]

37. John observed how his toy car moved on its own along a track. Position D on the track is lower than position A.

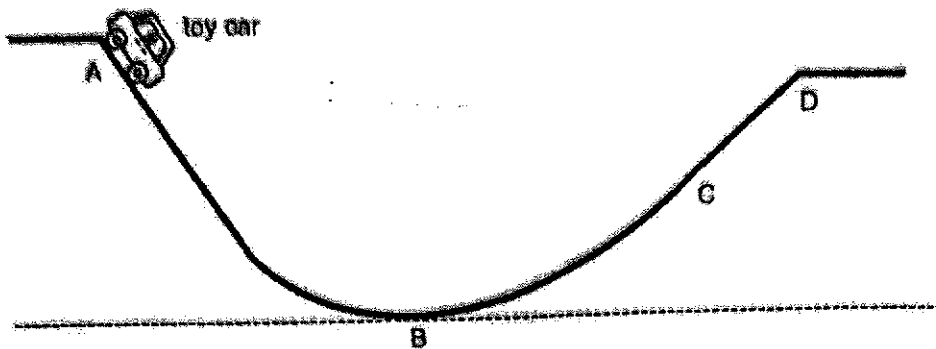

- (a) When John released the car at A, it moved past B and C but was not able to reach D. Explain in terms of energy conversion. [2]

- (b) State the main form(s) of energy the car will have at C. [1]

- (c) John applied oil on the surface of the track. He released the car at A again. This time, the car was able to reach D. Explain why. [2]

38 Mark conducted an experiment using two identical jars as shown below. Jar E is wrapped with bubble wrap while jar F is not. Bubble wrap is a plastic wrapping containing many small air pockets. Both jars were filled with 800 cm³ of hot water at 90 °C and left on the kitchen table.

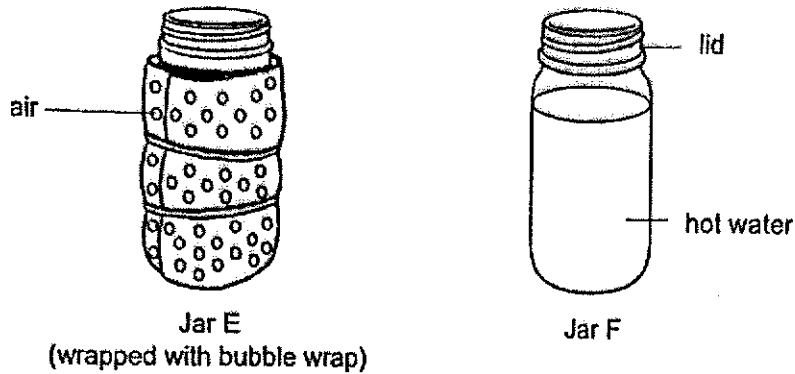

After 30 minutes, Mark observed that the temperature of water in Jar E was higher than the temperature of water in Jar F.

(a) What can Mark conclude about air from his observation? [1]

(b) During colder months, bird Q fluffs up its feathers to keep itself warm.

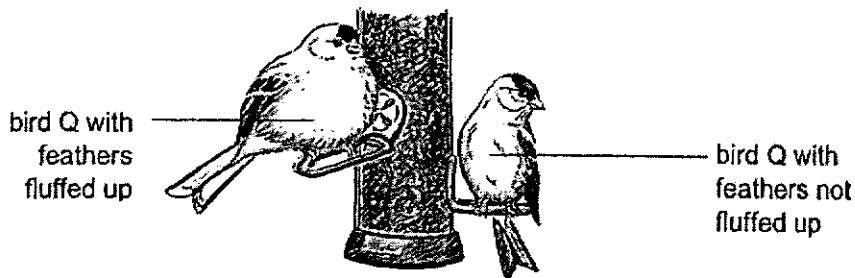

Based on the observations from Mark's experiment, explain how fluffing up of feathers helps bird Q to keep itself warm. [2]

39 Graph 1 shows the increase in length of two springs, X and Y, when loads were hung from them.

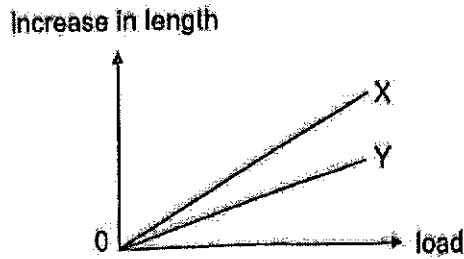

Graph 1

(a) Based on Graph 1, which spring, X or Y, is stiffer? Give a reason for your answer. [1]

Aisha conducted an experiment using spring Z. She hung a 10 g load from Z and measured the increased in length of Z. She repeated the experiment by adding a 10 g load, one at a time, until the total load was 50 g.

Next, Aisha started to remove a 10 g load, one at a time, until there was no more load left. Graph 2 shows her results.

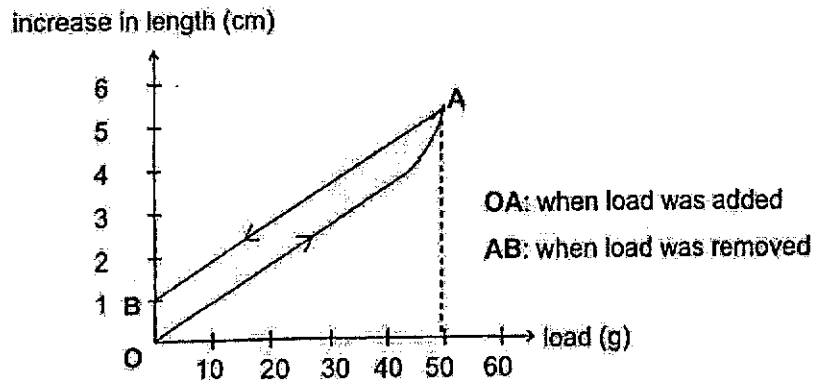

Graph 2

(b) If the original length of spring Z was 5 cm, what was its length after all the loads were removed? Give a reason for your answer. [2]

	3
--	---

SCHOOL : MARIS STELLA HIGH SCHOOL (PRIMARY)
LEVEL : PRIMARY 6
SUBJECT : SCIENCE
TERM : 2024 PRELIM

SECTION A

Q1	Q2	Q3	Q4	Q5	Q6	Q7	Q8	Q9	Q10
2	4	2	3	3	2	3	3	3	4
Q11	Q12	Q13	Q14	Q15	Q16	Q17	Q18	Q19	Q20
1	4	4	4	4	2	2	4	1	1
Q21	Q22	Q23	Q24	Q25	Q26	Q27	Q28		
1	2	2	4	1	2	4	4		

SECTION B

Q29a)	Blood, heart and blood vessels
Q29b)	Digested food is absorbed into the bloodstream in the small intestine. Blood transports the digested food to all parts of the body.
Q30a)	There are fewer trees to take in carbon dioxide so more heat is trapped on Earth.
Q30b)	There are less roots to hold the soil together so more soil will be washed into the river. The submerged plants will receive less light and photosynthesis is less.
Q31a)	Stage A: Egg Stage C: Pupa
Q31b)	When oil is sprayed on the top of the stagnant water, it blocks the breathing tube of the larva so the larva is unable to receive atmospheric air and dies.
Q31c)	Stage B is the only stage in the lifecycle of a mosquito where it can fly and spread diseases.

Q32a)	When the population of F decreases, there will be less F that feeds on R and M, hence populations of R and M increases. This increase leads to more R and M feeding on W, hence population of W decreases.
Q32b)	Fruit: ovary Seed: ovules
Q32c)	R will swallow the indigestible seeds and travel to other places, where the seeds are passed out in the droppings.
Q32d)	The animal droppings will provide nutrients for the young plant of W.
Q33a)	Water
Q33b)	The fallen leaves will decompose and provide nutrients for Plant A.
Q33c)	Set-up P has more leaves, more water from the stomata of the leaves will evaporate into more water vapour. More water vapour will condense on the surface of the container.
Q34a)	1. Animal J will be able to hear where its prey is and feed on them. 2. Animal J will be able to detect its predators easily.
Q34b)	Since the ears of J are big, its ears will have more exposed surface area allowing it to lose more heat to the surroundings.
Q35a)	Sealed glass container: tick D and E Cotton fabric bag: tick D
Q35b)	E is a gas at 30°C so it cannot escape in the sealed glass container.
Q36a)	C: Blue E: Blue light had the most amount of light detected by the light sensor. R: Most amount of blue light reflects off the object into Eric's eyes.
Q36b)	Prepare the same kind of torch, amount of water and light sensor but use a glass container of length 25cm instead of 50cm.
Q37a)	Some of the kinetic energy of the moving car is converted to heat energy as it moves along the track. The car will not have enough kinetic energy to be converted to potential energy.
Q37b)	Kinetic energy, (gravitational) potential energy
Q37c)	Oil is a lubricant which reduces friction between the wheels of the toy car and the track. Less kinetic energy of the car is converted into heat and sound energy, more kinetic energy will be converted into gravitational potential energy to reach D.

Q38a)	Air is a poor conductor of heat.
Q38b)	The fluffed feathers will trap more air as there are more air spaces between its feathers. Since air is a poor conductor of heat, less heat will be lost to the surroundings, keeping the bird warm.
Q39a)	Y. When the same amount of load is placed on both springs, Y stretches less.
Q39b)	6cm. The spring was overstretched as there was too much weight for the spring to hold.
Q40a)	When the switch is closed, a closed circuit is formed. Electric current is able to flow through the circuit and the bulb lights up while the iron rod becomes an electromagnet. The electromagnet attracts Bar Z, creating an open circuit, and bulb will not light up.
Q40b)	Electrical conductor, non-magnetic material.

